

BCM Series LCD Monitor

User Manual

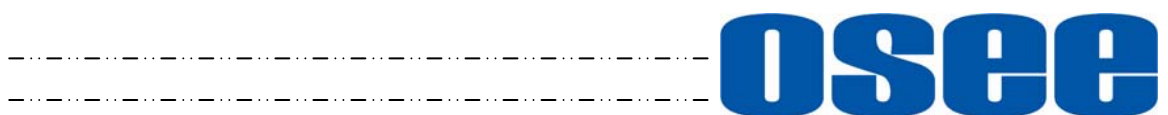

Product Information

Model: BCM-156/170/215/230 Series LCD Monitor
Version: V010200
Release Date: July 14th, 2016

Company

OSEE TECHNOLOGY CO., LTD.

Contact Information

Address: No.22 Building, No.68 zone, Beiqing Road, Haidian District,
Beijing, China
Post Code: 100094
Tel: (+86) 010-62434168
Fax: (+86) 010-62434169
Web: <http://www.osee-dig.com/>
E-mail: sales@osee-dig.com

About this manual

Important

The following symbols are used in this manual:

Tips

- The further information or know-how for described subjects above which helps user to understand them better.
-

Warning

- The safety matters or operations that user must pay attention to when using this product.
-

Contents

The user manual applies to the following device types:

| | | | |
|---------------------|---------------------|---------------------|---------------------|
| BCM-156-3HSV | BCM-170-3HSV | BCM-215-3HSV | BCM-230-3HSV |
| BCM-156-HSV | BCM-170-HSV | BCM-215-HSV | BCM-230-HSV |
| BCM-156-SV | BCM-170-SV | BCM-215-SV | BCM-230-SV |
| BCM-156-V | BCM-170-V | BCM-215-V | BCM-230-V |

The above listed devices have most similarities on appearance and characteristics. The images of BCM-156-3HSV are adopted in the following descriptions.

Any of the different specifications between the device types are elaborated. Before reading the manual, please confirm the device type.

Contents

| | |
|--|-----------|
| Contents | 1 |
| Chapter 1 Overview | 1 |
| Chapter 2 Safety..... | 3 |
| Chapter 3 Unpack and Installation | 7 |
| Chapter 4 BCM Features | 9 |
| 4.1 Front Panel Features | 11 |
| 4.1.1 Arrangement of Front Panel | 11 |
| 4.1.2 Operation of Front Panel | 12 |
| 4.2 Rear Panel Features..... | 16 |
| 4.2.1 Arrangement of Rear Panel | 17 |
| 4.2.2 Operations of Rear Panel | 19 |
| 4.3 Supported Signal Format | 22 |
| Chapter 5 Functionality of the Main Menu..... | 25 |
| 5.1 Main Menu | 25 |
| 5.1.1 STATUS Menu | 27 |
| 5.1.2 INPUT SELECT Menu | 29 |
| 5.1.3 MARKER Menu | 32 |
| 5.1.4 AUDIO Menu | 35 |
| 5.1.5 DISPLAY Menu | 39 |
| 5.1.6 CLOSED CAPTION Menu | 41 |
| 5.1.7 CONFIG Menu..... | 43 |
| 5.1.8 COLOR TEMP Menu | 50 |
| 5.1.9 FUNCTION KEY Menu | 52 |
| 5.1.10 GPI Menu..... | 54 |
| 5.1.11 IMD Menu | 57 |
| 5.1.12 KEY INHIBIT Menu | 73 |
| 5.2 Menu Settings..... | 74 |
| Chapter 6 Network Control..... | 79 |
| 6.1 Access the settings..... | 79 |
| 6.2 Menu Control | 80 |

| | |
|---------------------------------------|-----------|
| 6.2.1 ADJUST Menu..... | 81 |
| 6.2.2 VIDEO DISPLAY Menu | 83 |
| 6.2.3 SYSTEM Menu | 83 |
| 6.2.4 Other Menus..... | 84 |
| 6.3 Parameter Settings | 85 |
| Chapter 7 Specifications | 89 |

Chapter 1 Overview

The BCM series LCD Monitor are high performance broadcast monitor tailoring most applications from program production, intensive upload/download, playout to studio and intensive monitoring all sorts of business in TV Stations. The front frame of the unit comes in a slim bezel design made from rubber mold. The professional IPS glass at full resolution of 1920 x 1080 with LED backlight makes the BCM series LCD monitor capable of reproducing a natural color at quickest response time. In addition, the unit boasts a full wide viewing angle as well as excellent brightness and contrast ratio.

By adopting the advanced 10-bit digital signal processing technology plus 3D comb filter, de-interlacing capability and accurate scaling ensures the BCM series LCD Monitor to achieve a better effect of smoother and more natural image.

The BCM series LCD Monitor supports up to 2Ch 3G/HD/SD-SDI/analog input/output, 2Ch CVBS(LINE1, LINE2) input/output, IGRP Y/C input/output, IGRP YPbPr input/output, and 1Ch HDMI input. Featuring PBP/PIP and showing two signals simultaneously on the same screen makes the BCM with added value.

The BCM series LCD Monitor delivers much capable display functionality like waveform/vector scope, audio de-embedding, audio monitoring, audio metering bar, TC, CC, AFD, IMD and all kinds of markers.



Figure 1 A Diagram of BCM Monitor

Features

- Prevailing slim bezel design
- Having multi format input including 3G-SDI
- Adopting full HD, wide viewing angle IPS glass

Overview

- Using 10-bit signal processing technology plus advanced conversion technology between the interlacing and the progressive
- Featuring PBP and PIP, dual 3G-SDI capable under PBP mode
- Supporting waveform/vector scope, audio metering bar, TC, IMD and CC
- Supporting varied color temperature, varied scan modes, flexibility in marker setting, Blue Only/Monochrome mode

Functionality

- Supports MARKER, Time Code, MET display
- Supports presetting the color temperature using customized values

Chapter 2 Safety

FCC Caution:

Any Changes or modifications not expressly approved by the party responsible for compliance could void the user's authority to operate the equipment.

This device complies with part 15 of the FCC Rules.

Operation is subject to the following two conditions: (1) This device may not cause harmful interference, and (2) this device must accept any interference received, including interference that may cause undesired operation.

Note: This equipment has been tested and found to comply with the limits for a Class B digital device, pursuant to part 15 of the FCC Rules. These limits are designed to provide reasonable protection against harmful interference in a residential installation. This equipment generates uses and can radiate radio frequency energy and, if not installed and used in accordance with the instructions, may cause harmful interference to radio communications. However, there is no guarantee that interference will not occur in a particular installation. If this equipment does cause harmful interference to radio or television reception, which can be determined by turning the equipment off and on, the user is encouraged to try to correct the interference by one or more of the following measures:

Reorient or relocate the receiving antenna.

Increase the separation between the equipment and receiver.

Connect the equipment into an outlet on a circuit different from that to which the receiver is connected.

Consult the dealer or an experienced radio/TV technician for help.

Warnings:

Read, keep and follow all of these instructions for your safety. Heed all warnings.

Warning

Device

- Install in accordance with the manufacturer's instructions.
 - Do not beat with a hard object or scratch the LCD display.
 - Do not make the freeze picture displaying on the screen time too long, otherwise, it will leave the afterimage on the screen.
 - If the brightness is adjusted to the minimum, then it might be hard to see the display screen.
 - Refer all servicing to qualified service personnel. Servicing will be required under all of the following conditions:
 - The unit has been exposed to rain or moisture.
 - Liquid had been spilled or objects have fallen onto the unit.
 - The unit has been damaged in any way, such as when the power-supply cord or plug is damaged.
 - The unit does not operate normally.
 - Clean only with dry cloth.
 - Specifications are subject to change without notice.
-

Warning

Position

- Do not block any ventilation openings.
- Do not use this unit near water.
- Do not expose the unit to rain or moisture.
- Do not use this unit near any heat sources such as radiators, heat registers, stoves, or other apparatus (including amplifiers) that product

heat.

- A nameplate indicating operating voltage, etc., is located on the rear panel.
 - The socket-outlet shall be installed near the equipment and shall be easily accessible.
-

Warning

Power Supply Cord

- Do not defeat the safety purpose of the polarized or grounding-type plug.
 - Do not damage the power cord, place the heavy objects on the power cord, stretch the power cord, or bend the power cord.
 - Protect the power cord from being walked on or pinched, particularly at plugs, convenience receptacles, and the point where they exit from the unit.
 - If the power cord is damaged, turn off the power immediately. It is dangerous to use the unit with a damaged power cord. It may cause fire or electric shock.
 - Unplug this unit during lightning storms or when unused for long periods of time.
 - Disconnect the power cord from the AC outlet by grasping the plug, not by pulling the cord.
 - Should any solid object or liquid fall into the cabinet, unplug the unit and have it checked by qualified personnel before operating it any further.
-

032222

Chapter 3 Unpack and Installation

Unpack:

When unpacking the components of BCM-156 monitor, please verify that none of the components listed in Table 3.1 are damaged or lack. If there is any missing, contact your distributors or Osee Technology Co., Ltd. for it.

Table 3-1 Packing List

| No. | Item | Quantity |
|-----|----------------------|----------|
| 1 | Device | 1 |
| 2 | Pedestal with screws | 1 |
| 3 | Power cord | 1 |
| 4 | adapter | 1 |
| 5 | User manual | 1 |
| 6 | Warranty card | 1 |
| 7 | Certificate card | 1 |

Installation:

1. Prepare for installation

Please follow the procedures below before installing BCM-156:

- Check the equipment for any invisible damage that may have occurred during transit.
- Confirm all the items listed on the packing list have been received.
- Remove all the packing material including electrostatic-resistant packing.
- Retain these packing materials for future use.

2. Mount a BCM-156 in your desired location of a standard rack.

Adequate ventilation is required when installed to prevent possible damage to the BCM-156.

3. Connect required cables for signal input and output. For BNC connections use 75 Ω rated connectors.

4. Connect 12V5A DC power source using the included power cord.

5. Connect the power cord to the power interface.

6. Fasten the power protect accessory.

7. As a final step, turn on the device by pressing the corresponding power switch located on the front panel.

 **Tips**

- The pedestal and the monitor are packaged separately.
 - Connect a standard signal line to the corresponding input port. All BNC connector impedance must be 75Ω.
 - Please use the power adapter supplied to avoid unnecessary trouble.
 - The factory default value for IP address is 192.168.1.86.
-

Chapter 4 BCM Features

This chapter describes the features of BCM-156 monitor. The features of BCM-156 monitor are as shown in Figure 4-1 after installed and powered on:

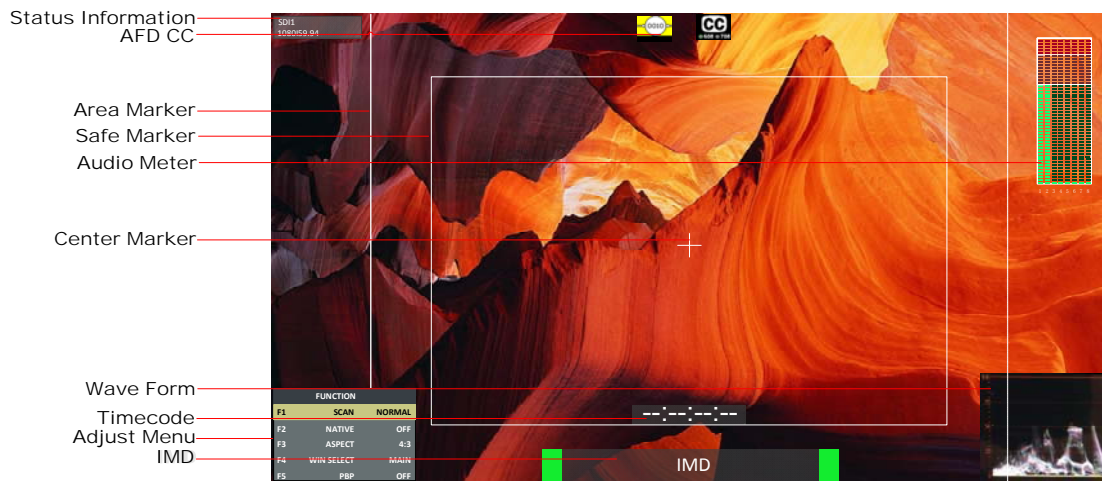
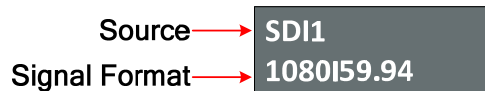

Figure 4-1 Features of BCM-156 Monitor

1. Status Information

It is displayed in the top left corner of the screen, and includes the input channel and signal format. You can define it in DISPLAY menu.



2. Waveform and Vector

This is effective only for SDI signal. The waveform and vector of the input signal are configurable in the MAIN Menu.

3. Area Marker

It is used to mark different area of the image. You can set whether to display it or not and their displaying mode in **MARKER** menu.

4. Safe Marker

It is used to mark different area of the image. You can set whether to display it or not and their displaying mode in **MARKER** menu.

5. Center Marker

It is displayed in the center of the screen, and marks the center of the

image. You can set whether to display it or not in **MARKER** menu.

6. Audio Meter

It is displayed for audio monitoring. You can set its groups, direction, position and mode in **AUDIO** menu.

7. Timecode

It is displayed at the bottom of the image, the format is HH:MM:SS:FF, if there is no timecode available, the monitor will display --:--:--:--.

8. IMD

The IMD text displays at the bottom of the screen, the length can't exceed 16 characters, and you can choose letter, number or other character for it.

9. AFD/CC

AFD and CC information will display at the top center of the screen as an icon.

10. MUTE

The icon for MUTE is . When it is mute, this icon displays at the bottom right position of the screen. You can set this function in function key.

Tips

- The **Status Information** usually displays as the following situations:
 - "UNKNOWN" appears if an unsupported signal is input.
 - "NO SIGNAL" appears if no signal is input.
 - The signal is normal, for example: 1080i59.94, NTSC, 1280X1024, etc.
 - When the monitor is set in PIP or PBP mode by setting the **CONFIG→SUB IN TYPE** menu item, the **Status Information** for the main picture displays at the top left corner of the screen, and the **Status Information** for the slave picture displays at the top right corner of the screen.
 - The AFD information displays at the top center of the screen.
-

4.1 Front Panel Features

It will introduce the arrangement and the operations of the buttons in front of the panel in the following.

4.1.1 Arrangement of Front Panel

There are a series of buttons at the bottom of the screen, and these buttons are used to control the screen menu items.

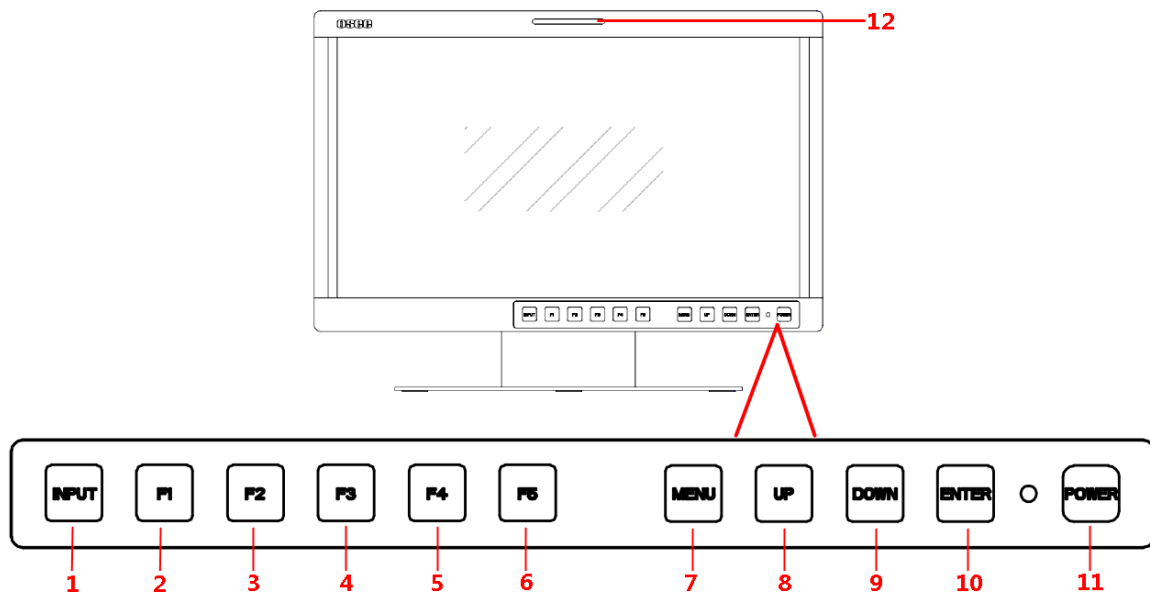

Figure 4.1-1 the Buttons in Front Panel

As shown in Figure 4.1-1, take the left screen of BCM-156 for example, these buttons are as follows:

1. INPUT
2. F1
3. F2
4. F3
5. F4
6. F5
7. MENU
8. UP
9. DOWN
10. ENTER

11. POWER

12. TALLY: **TALLY indicator(LED TALLY)**

i Tips

- Only the POWER button has a light indicator.

4.1.2 Operation of Front Panel

The functionality and usage of the buttons at the front panel are as follows:

1. INPUT

Select the input signal. Press this button to display the input source menu at the right top corner of the screen, as shown in Figure 4.1-2. Use it to select an input signal source, press it again to toggle among these input signal items, or after the input source menu displayed, use the UP/DOWN button to toggle among these input signal items.

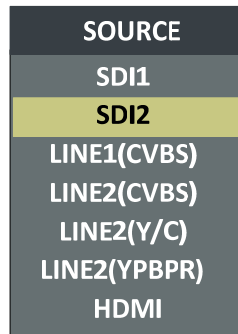

Figure 4.1-2 Source Menu

The one-to-one correspondence between the signals in the source menu list and the interfaces in the back panel are shown in Figure 4.1-3:

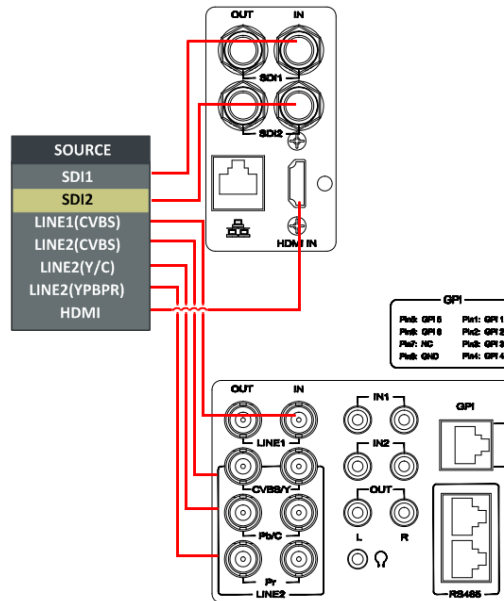

Figure 4.1-3 Correspondence between Source Menu and Interface

i Tips

- When the monitor is set as PIP/PBP display mode, set the signal source for the main picture by INPUT button, and refer to “5.1.7 CONFIG Menu” for the settings about the signal source for the slave picture.

2. F1

This button is a FUNCTION button. The function can be set via the FUNCTION menu. Open the FUNCTION menu after the first time, the selected function will remain.

- **OPERATION:** Press **F1** to display the function menu list in the center of the screen, as shown in Figure 4.1-4. Toggle **F1** button to change the value related to this function.

| FUNCTION | | |
|-----------|-------------------|---------------|
| F1 | SCAN | NORMAL |
| F2 | NATIVE | OFF |
| F3 | ASPECT | 4:3 |
| F4 | WIN SELECT | MAIN |
| F5 | PBP | OFF |

Figure 4.1-4 Function Menu List

i Tips

- After you have loaded the function menu list, it will be closed automatically if you do nothing operation with it in 10s.
 - If the value related to the function button can't be modified, the value shows in blue.
 - Use **FUNCTION KEY** menu to assign F1~F5. You can assign the function from among: SCAN, NATIVE, ASPECT, BLUE ONLY, MONO, MARKER, H/V DELAY, AUDIO METER, FAST MODE, TC, IMD, MUTE, PBP, CC, FREEZE, WIN SELECT, FOCUS ASSIST, LUMA ZOOM CHECK, H FLIP, UNDEF. Refer to "5.1.9 FUNCTION KEY Menu" for the details.
-

3. F2

It is used to activate to F2 function button. The operation is as the same as F1's.

i Tips

- Press and hold the **INPUT+F2** button for 3s can reset the menu settings to factory originals, as shown in Figure 4.1-5.
-

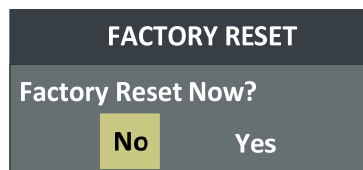

Figure 4.1-5 Reset Menu List

4. F3

It is used to activate to F3 function button. The operation is as the same as F1's.

5. F4

It is used to activate to F4 function button. The operation is as the same as F1's.

6. F5

It is used to activate to F5 function button. The operation is as the same

as F1's.

7. MENU

It is used to activate the Main menu. Press this button to do some operations with the Main menu, it includes the following operations:

- Display the Main menu
- Back to the higher level menu
- Quit the Main menu

Refer to “5.2 Menu Settings” for detail about the main menu operations.

8. UP

It is **UP** button when working with **MENU**. Toggle this button to select the next item or increase the number.

9. DOWN

It is **DOWN** button when working with **MENU**. Toggle this button to select the next item or decrease the number.

10. ENTER

This button can achieve the following two situations:

- **Work with the Main MENU:** when working with the Main menu, ENTER button achieve the following functions:
 - Enter into the next level menu: press **ENTER** button, you will enter into the menu item as this relationship: the Main menu list→ sub-menu list→ sub-menu value list, the current editable object is in yellow control icon;
 - Confirm the value selection: press **ENTER** button to confirm the value selection.
- **Adjust Menu:** when not displaying the Main menu, press **ENTER** button to display the adjust menu list, as shown in Figure 4.1-6, toggle among these menu items: VOLUME, BRIGHTNESS, CONTRAST, CHROMA.



Figure 4.1-6 Adjust Menu List

After displaying the Adjust menu, press **UP** or **DOWN** button to adjust the menu value, and then press **ENTER** button to confirm the value selection.

The relationship of the menu items and their range is shown in Table 4.1-1:

Table 4.1-1 The Description of Adjust Menu Items

| Adjust Menu | Description | Range | Default |
|-------------|-----------------------------|--------|---------|
| VOLUME | Adjust the volume | 0~31dB | 16 |
| BRIGHTNESS | Adjust the image brightness | 0~100 | 50 |
| CONTRAST | Adjust the image contrast | 0~100 | 50 |
| CHROMA | Adjust the image monochroma | 0~100 | 50 |

Tips

- Set these parameter values in the following position: BRIGHTNESS, CONTRAST, CHROMA.
 - In Adjust Menu List on screen when pressing Enter key.
 - In Adjust menu of network control page.
- After you have loaded the adjust menu list, it will be closed automatically if you do nothing operation with it in 10s.
- The main menu, the adjust menu, the function menu and the input signal selection list of a screen may not be shown all simultaneously.

11. Power

Used to power on or standby, and the light in the button will indicate the status of the power. If the light is green, the monitor is powered on, if the light is flashing, the monitor is standby.

Tips

- When the device is standby, cut off the power and restart the device, the status of the device will be normal but not standby.
-

4.2 Rear Panel Features

It will introduce the arrangement and the operations of the interfaces in rear of the panel in the following.

4.2.1 Arrangement of Rear Panel

For the arrangement of the rear panel of BCM-170, BCM-215 and BCM-230 are the same, which are different from the BCM-156's. It will take BCM-170 for example, as shown in Figure 4.2-1, there are various input and output interfaces at the rear panel of BCM-170 monitor.

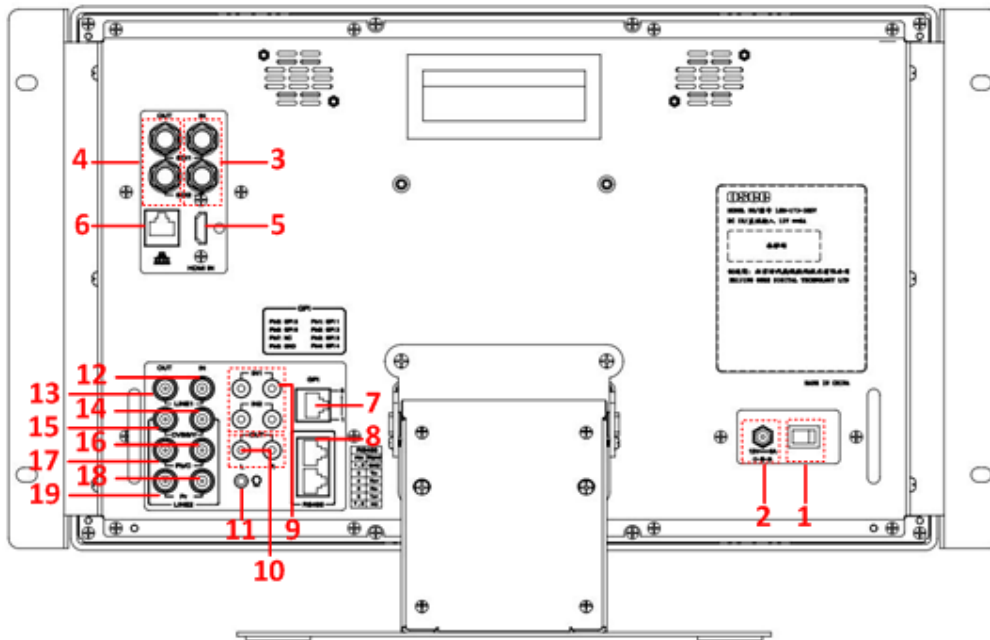

Figure 4.2-1 The Rear Panel of BCM-170 Monitor

The interfaces numbered from 1 to 8 in red dotted rectangle are described as follows:

1. **Power Switch**
2. **Power Input**
3. **Video Input: SDI1 IN, SDI2 IN**
4. **Video Output: SDI1 OUT, SDI2 OUT**
5. **HDMI Input**
6. **Ethernet**
7. **GPI interface**
8. **RS485 In/Out**
9. **Audio Input**
10. **Audio Output**
11. **Headphone Output Connector (3.5mm stereo Jack)**

12. Video Input: LINE1 IN
13. Video Output: LINE1 OUT
14. Video Input: LINE2(CVBS/Y) IN, feed the composited LINE2, or component Y signal.
15. Video Output: LINE2(CVBS/Y) OUT, output the composited LINE2, or component Y signal.
16. Video Input: LINE2(Pb/C) IN, feed the component Pb, or component C signal.
17. Video Output: LINE2(Pb/C) OUT, output the component Pb, or component C signal.
18. Video Input: LINE2(Pr) IN, feed the component Pr signal.
19. Video Output: LINE2(Pr) OUT, output the component Pr signal.

Tips

- Especially, the interface types of BCM-156 are as the same as BCM-170's (BCM-215/BCM-230), but the arrangement is different from the BCM-170's (BCM-215/BCM-230). The arrangement of rear panel of BCM-156 is as shown in Figure 4.2-2, the numbers of the interfaces are the same.

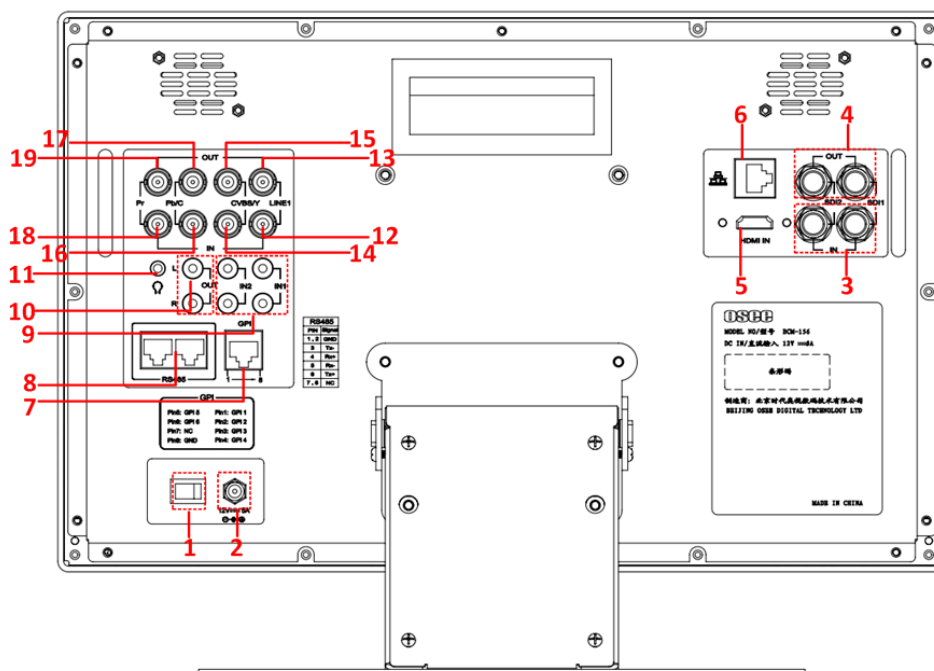

Figure 4.2-2 The Rear Panel of BCM-156 Monitor

4.2.2 Operations of Rear Panel

The details of these interfaces at the rear panel are described as follows:

1. Power Switch

It provides one power switch to switch on or switch off. As shown in Figure 4.2-3, push the button to the direction “-” to switch on the power, or push the button to the direction “O” to switch off the power.

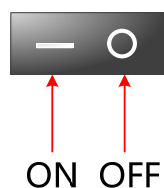

Figure 4.2-3 Power Switch

2. Power Input

It provides one power input interface, the specification is 12V5ADC. The corresponding indicator is at the front panel. If the light is green, the monitor is powered on, if the light is flashing, the monitor is standby, and if the light is off, the monitor is powered off.

Warning

- Only use the adapter and the power cord specified by the manufacture for your safety!

3. Video Input Interface (BNC)

It provides two SDI input interfaces, one is labeled as SDI1 IN, and the other is SDI2 IN.

4. Video Output Interface (BNC)

It provides two SDI output interfaces. One is labeled as SDI1 OUT, the other is SDI2 OUT, active loop.

5. HDMI

It provides one HDMI input interface, HDMI Type-A connector with a fastener.

6. Ethernet (RJ-45)

It provides one 10/100M Ethernet connector. It is used to connect with a computer to modify the network settings.

7. GPI(DB9)

It assigns a function to each pin of the GPI interface to realize a remote control mode. Define a function to the GPI pin. Refer to “5.1.10 GPI Menu” for the definition of the pins and the functions.

The relationship of the pins of GPI interface and its channel value is shown in Table 4.2-1.

Table 4.2-1 The Relationship of GPI Pins and Channel Values

| Pin No. | Channel Value |
|---------|---------------|
| Pin 1 | GPI1 |
| Pin 2 | GPI2 |
| Pin 3 | GPI3 |
| Pin 4 | GPI4 |
| Pin 5 | GPI5 |
| Pin 6 | GPI6 |
| Pin 7 | NC |
| Pin 8 | GND |

8. IN/ OUT RS485 Interface (RJ-45)

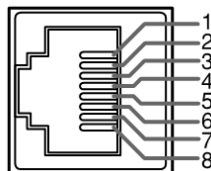

Support for dynamic IMD and updating the new firmware.

The Comparison of Pins and Input/output connectors for RS485 is shown as in Table 4.2-2:

Table 4.2-2 The Comparison of Pins and Input/output connectors for RS485

| PIN No. | RS485 IN Terminal Signal | RS485 OUT Terminal Signal |
|---------|--------------------------|---------------------------|
| 1,2 | GND | GND |
| 3 | Tx- | Tx- |
| 4 | Rx+ | Rx+ |
| 5 | Rx- | Rx- |
| 6 | Tx+ | Tx+ |
| 7,8 | NC | NC |

9. Audio Input interface

It provides four audio input interfaces, 5dBu, impedance $\geq 47K$, RCA connector.

10. Audio Output interface

It provides two audio output interfaces, 5dBu, impedance $\leq 500 \Omega$, RCA connector.

11. Video Input/Output Interface (BNC)

It provides two pairs of Compositd Video input/output interfaces (LINE1, LINE2), and a group of component signals (YPbPr, Y/C), the Y/C signal is also called as S-Video. It will transmit the corresponding component signal to different signal type according to the selection of the signal source.

As shown in Figure 4.2-4, the relationship of the signal sources and the interfaces are shown as in Table 4.2-3:

Table 4.2-3 The Relationship of the Signal Sources and Input/output Interfaces

| Signal Source | Video Input | Video Output |
|---------------|--|---|
| LINE1 | LINE1 IN | LINE1 OUT |
| LINE2(CVBS) | LINE2(CVBS/Y) IN | LINE2(CVBS/Y) OUT |
| LINE2(Y/C) | LINE2(CVBS/Y) IN LINE2(Pb/C) IN | LINE2(CVBS/Y) OUT LINE2(Pb/C) OUT |
| LINE2(YPBPR) | LINE2(CVBS/Y) IN LINE2(Pb/C) IN LINE2(Pr) IN | LINE2(CVBS/Y) OUT LINE2(Pb/C) OUT LINE2(Pr) OUT |

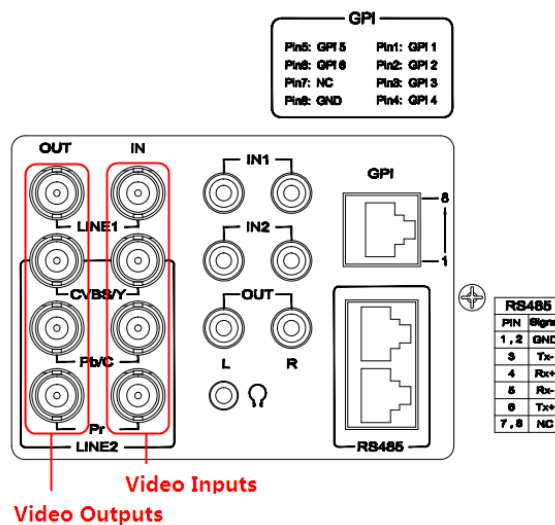

Figure 4.2-4 Video Input/Output Interfaces

4.3 Supported Signal Format

The supported signal format for this device is as shown in Table 4.3-1:

Table 4.3-1 Supported Signal Format

| | SDI | VIDEO | YC | YPBPR | HDMI |
|----------------------|-----|-------|----|-------|------|
| PAL | | ✓ | ✓ | | |
| NTSC | | ✓ | ✓ | | |
| 480I60/59.94 | ✓ | | | ✓ | ✓ |
| 576I50 | ✓ | | | ✓ | ✓ |
| 480P60/59.94 | | | | ✓ | ✓ |
| 576P50 | | | | ✓ | ✓ |
| 720P24/23.97 | ✓ | | | ✓ | |
| 720P25 | ✓ | | | ✓ | ✓ |
| 720P30/29.97 | ✓ | | | ✓ | ✓ |
| 720P50 | ✓ | | | ✓ | ✓ |
| 720P60/59.94 | ✓ | | | ✓ | ✓ |
| 1080SF24/23.97 | ✓ | | | ✓ | ✓ |
| 1035I60/59.94 | ✓ | | | ✓ | ✓ |
| 1080I50 | ✓ | | | ✓ | ✓ |
| 1080I60/59.94 | ✓ | | | ✓ | ✓ |
| 1080P24/23.97 | ✓ | | | ✓ | ✓ |
| 1080P25 | ✓ | | | ✓ | ✓ |
| 1080P30/29.97 | ✓ | | | ✓ | ✓ |
| 1080P50 | ✓ | | | ✓ | ✓ |
| 1080P60/59.94 | ✓ | | | ✓ | ✓ |
| 2048X1080PSF24/23.97 | ✓ | | | | |
| 2048X1080PSF25 | ✓ | | | | |
| 2048X1080PSF30/29.97 | ✓ | | | | |
| 2048X1080P24/23.97 | ✓ | | | | ✓ |
| 2048X1080P25 | ✓ | | | | ✓ |
| 2048X1080P30/29.97 | ✓ | | | | ✓ |
| 2048X1080P48/47.94 | ✓ | | | | ✓ |

| | SDI | VIDEO | YC | YPBPR | HDMI |
|--------------------|-----|-------|----|-------|------|
| 2048X1080P50 | ✓ | | | | ✓ |
| 2048X1080P60/59.94 | ✓ | | | | ✓ |
| VGA(640X480) | | | | | ✓ |
| SVGA(800X600) | | | | | ✓ |
| XGA(1024X768) | | | | | ✓ |
| SXGA(1280X1024) | | | | | ✓ |
| WXGA(1360X768) | | | | | ✓ |
| WXGA+(1440X900) | | | | | ✓ |
| WXGA+(1400X1050) | | | | | ✓ |
| UXGA(1600X1200) | | | | | ✓ |
| UXGA+(1680X1050) | | | | | ✓ |
| WUXGA(1920X1080) | | | | | ✓ |
| WUXGA(1920X1200) | | | | | ✓ |

032222

Chapter 5 Functionality of the Main Menu

This chapter describes the structure and functionality of the main menu, and introduces how to modify and customize the menu settings.

The main menu includes the following menu items, as shown in Figure5-1.



Figure 5-1 Main Menu

5.1 Main Menu

Press the **MENU** button at the bottom of the front panel, the main menu is displayed at the top left corner of the screen, as shown in Figure 5.1-1:

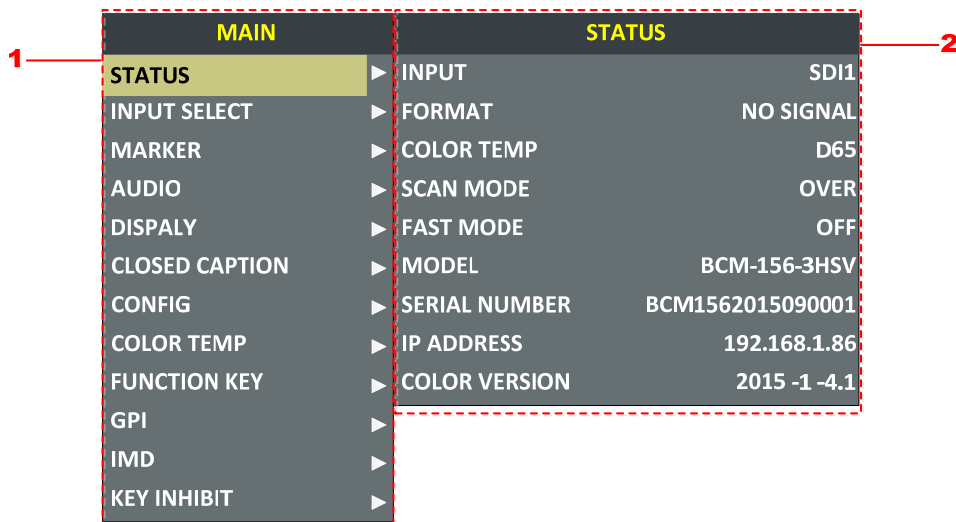

Figure 5.1-1 the Structure of the Main Menu

The menu interface is divided into three parts:

1. Main Menu List

It contains the title of the Main menu and several sub-menu items. The title of this list is **MAIN**. Press **UP** or **DOWN** to access the corresponding menu item.

2. Sub-menu list

As shown in Figure 5.1-2, it lists the title of the **Sub-menu**, the sub-menu item and the value of the item. After pressing **Menu** button, press **UP**, **DOWN** button and **Enter** button to modify the value of the sub-menu. Refer to “5.2 Menu Settings” for details.

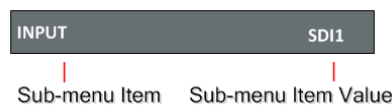

Figure 5.1-2 the Sub-menu Value List

There is a yellow control icon when you select the menu or its value.

i Tips

- The sub-menu item is selected when the control icon which is in yellow highlight is at the back of the item name.
- The sub-menu item value is editable when the control icon which is in yellow highlight is at the back of the item value.

The control icon of the main menu has the following status when in different positions, as shown in the red rectangle of the following figures:

- when in the main menu, it shows that this menu item is selected, as shown in Figure 5.1-3:

| MAIN | | INPUT SELECT | |
|---------------------|---|-----------------|------|
| STATUS | ▶ | SDI1 | ON |
| INPUT SELECT | ▶ | SDI2 | ON |
| MARKER | ▶ | LINE1 | ON |
| AUDIO | ▶ | LINE2 | CVBS |
| DISPALY | ▶ | HDMI | ON |
| CLOSED CAPTION | ▶ | NTSC SETUP | 7.5 |
| CONFIG | ▶ | NTSC PHASE | 0 |
| COLOR TEMP | ▶ | FOCUS ASSIST | OFF |
| FUNCTION KEY | ▶ | FOCUS LEVEL | 50 |
| GPI | ▶ | FOCUS COLOR | RED |
| IMD | ▶ | LUMA ZOOM CHECK | OFF |
| KEY INHIBIT | ▶ | LUMA ZOOM LEVEL | 50 |

Figure 5.1-3 A Main Menu Item Is Selected

- when in the sub-menu item, it shows that this sub-menu item is selected, and the control icon is displayed as a yellow rectangle in front of it, as shown in Figure 5.1-4:

| MAIN | INPUT SELECT | |
|----------------|-------------------|------|
| STATUS | ▶ SDI1 | ON |
| INPUT SELECT | ▶ SDI2 | ON |
| MARKER | ▶ LINE1 | ON |
| AUDIO | ▶ LINE2 | CVBS |
| DISPALY | ▶ HDMI | ON |
| CLOSED CAPTION | ▶ NTSC SETUP | 7.5 |
| CONFIG | ▶ NTSC PHASE | 0 |
| COLOR TEMP | ▶ FOCUS ASSIST | OFF |
| FUNCTION KEY | ▶ FOCUS LEVEL | 50 |
| GPI | ▶ FOCUS COLOR | RED |
| IMD | ▶ LUMA ZOOM CHECK | OFF |
| KEY INHIBIT | ▶ LUMA ZOOM LEVEL | 50 |

Figure 5.1-4 A Sub-menu Item Is Selected

- when in the sub-menu item value, it shows that this sub-menu item value is selected, and the value is displayed in yellow, as shown in Figure 5.1-5:

| MAIN | INPUT SELECT | |
|----------------|-------------------|------|
| STATUS | ▶ SDI1 | ON |
| INPUT SELECT | ▶ SDI2 | ON |
| MARKER | ▶ LINE1 | ON |
| AUDIO | ▶ LINE2 | CVBS |
| DISPALY | ▶ HDMI | ON |
| CLOSED CAPTION | ▶ NTSC SETUP | 7.5 |
| CONFIG | ▶ NTSC PHASE | 0 |
| COLOR TEMP | ▶ FOCUS ASSIST | OFF |
| FUNCTION KEY | ▶ FOCUS LEVEL | 50 |
| GPI | ▶ FOCUS COLOR | RED |
| IMD | ▶ LUMA ZOOM CHECK | OFF |
| KEY INHIBIT | ▶ LUMA ZOOM LEVEL | 50 |

Figure 5.1-5 A Sub-menu Item Value Is Selected

The following will introduce the contents and functionality of these sub-menu items in sorts.

5.1.1 STATUS Menu

The STATUS menu items are used to describe the current status information of the monitor, the menu items are as shown in Figure 5.1-6:

| MAIN | STATUS |
|----------------|--------------------------------|
| STATUS | INPUT SDI1 |
| INPUT SELECT | FORMAT NO SIGNAL |
| MARKER | COLOR TEMP D65 |
| AUDIO | SCAN MODE OVER |
| DISPALY | FAST MODE OFF |
| CLOSED CAPTION | MODEL BCM-156-3HSV |
| CONFIG | SERIAL NUMBER BCM1562015010001 |
| COLOR TEMP | IP ADDRESS 192.168.1.86 |
| FUNCTION KEY | COLOR VERSION 2015 -1 -4.1 |
| GPI | |
| IMD | |
| KEY INHIBIT | |

Figure 5.1-6 STATUS Menu

The relationship of Items, Default Value, Domain Range and Description of the sub-item is shown in Table 5.1-1:

Table 5.1-1 The Description of STATUS Menu Items

| Items | Default Value | Domain Range | Description |
|------------|---------------|--|-------------------------------------|
| INPUT | SDI1 | <ul style="list-style-type: none"> SDI1 SDI2 LINE1(CVBS) LINE2(CVBS) LINE2(Y/C) LINE2(YPBPR) HDMI | Show the Input format |
| FORMAT | NO SIGNAL | -- | Show the format of the input signal |
| COLOR TEMP | D65 | -- | Show the color temperature. |
| SCAN MODE | NORMAL | <ul style="list-style-type: none"> NORMAL OVER UNDER | Show the scan mode. |
| FAST MODE | OFF | OFF/ON | Show the fast mode. |
| SD ASPECT | 16:9 | 16:9/4:3 | Show the screen Aspect Ratio. |
| MODEL | BCM-156-3HSV | -- | Show the production |

| Items | Default Value | Domain Range | Description |
|---------------|------------------|--------------|--|
| | | | model. |
| SERIAL NUMBER | BCM1562015010001 | -- | Show the serial number. |
| IP ADDRESS | 192.168.1.86 | -- | Show the IP address. |
| COLOR VERSION | 2015-1-4.1 | -- | Show the color version according to its adjusted date. |

Tips

- The sub-menu values in **STATUS** menu can't be modified, they are displayed the actual status of the monitor.

5.1.2 INPUT SELECT Menu

The INPUT SELECT menu items are used to set the source of the input signals, the menu items are as shown in Figure 5.1-7:

| MAIN | INPUT SELECT | |
|----------------|-----------------|------|
| STATUS | SDI1 | ON |
| INPUT SELECT | SDI2 | ON |
| MARKER | LINE1 | ON |
| AUDIO | LINE2 | CVBS |
| DISPALY | HDMI | ON |
| CLOSED CAPTION | NTSC SETUP | 7.5 |
| CONFIG | NTSC PHASE | 0 |
| COLOR TEMP | FOCUS ASSIST | OFF |
| FUNCTION KEY | FOCUS LEVEL | 50 |
| GPI | FOCUS COLOR | RED |
| IMD | LUMA ZOOM CHECK | OFF |
| KEY INHIBIT | LUMA ZOOM LEVEL | 50 |

Figure 5.1-7 INPUT SELECT Menu

The relationship of Items, Default Value, Domain Range and Description of the sub-item is shown in Table 5.1-2:

Table 5.1-2 The Description of INPUT SELECT Menu Items

| Items | Default Value | Domain Range | Description |
|-----------------|---------------|---|--|
| SDI1 | ON | ON/OFF | Enable/Disable SDI1 input |
| SDI2 | ON | ON/OFF | Enable/Disable SDI2 input |
| LINE1 | ON | ON/OFF | Enable/Disable LINE1 input |
| LINE2 | ON | <ul style="list-style-type: none"> • CVBS • LINE2(Y/C) • LINE2(YPBPR) • OFF | Enable/Disable LINE2 input, and select the input source |
| HDMI | ON | ON/OFF | Enable/Disable HDMI input |
| NTSC SETUP | 7.5 | 0/7.5 | Select the NTSC mode |
| NTSC PHASE | 0 | -50~50 | Set the NTSC phase |
| FOCUS ASSIST | OFF | <ul style="list-style-type: none"> • OFF • STANDARD: An image with sharpened edges is displayed. • COLOR: Displays the intensified areas of images with color selected in FOCUS COLOR. | Enable/Disable the focus assist function, and set the focus assist mode. |
| FOCUS LEVEL | 50 | 0~100 | Set the level of edge sharpening. |
| FOCUS COLOR | RED | RED/GREEN/BLUE | Set the color for the sharpened edge. |
| LUMA ZOOM CHECK | OFF | ON/OFF | Enable/Disable the luma zoom check function that will compare the signal luminance with the LUMA ZOOM LEVEL, and fill the relevant image area whose luminance is higher than the LUMA ZOOM LEVEL with a zebra pattern. |
| LUMA ZOOM LEVEL | 50 | 0~100 | Set the level of detecting luminance. |

1. FOCUS ASSIST

The FOCUS ASSIST function is used to display images on the screen with sharpened edges to help camera focus operation. The sharpened edges

are the compared area whose luminance is beyond the reference level, and the edges are displayed in the pointed color.

For example, set the **FOCUS COLOR** as RED, and set the **FOCUS LEVEL** as 80, the compared results are as shown Figure 5.1-8:



Figure 5.1-8 Illustration for FOCUS ASSIST Function

2. LUMA ZOOM CHECK

The LUMA ZOOM CHECK function is used to display images on the screen with a zebra pattern to adjust the camera exposure parameter. It will compare the signal luminance with the **LUMA ZOOM LEVEL**, and fill the relevant image area whose luminance is higher than the **LUMA ZOOM LEVEL** with a zebra pattern.

For example, set the **LUMA ZOOM LEVEL** as 80, the compared results are as shown in Figure 5.1-9, the special area is filled with a zebra pattern.



Figure 5.1-9 Illustration for LUMA ZOOM CHECK Function

Tips

- Select input source format for LINE2: For the LINE2(CVBS) interface, the LINE2(Y/C) interface and the LINE2(YPSPR) interface share the same group of physical interfaces, select the signal source format for LINE2 according to the line connection mode. When select a signal source format for LINE2, you can set the menu item **INPUT SELECT→LINE2** as CVBS, LINE2(Y/C) or LINE2(YPBPR), in addition, press **INPUT** button to pop up

the source list for LINE2 selection.

5.1.3 MARKER Menu

The MARKER menu items are used to adjust the marker parameters, the menu items are as shown in Figure 5.1-10:

| MAIN | | MARKER | |
|----------------|---|---------------|-----|
| STATUS | ▶ | MARKER | OFF |
| INPUT SELECT | ▶ | AREA MARKER | OFF |
| MARKER | ▶ | CENTER MARKER | OFF |
| AUDIO | ▶ | SAFETY MARKER | OFF |
| DISPALY | ▶ | MARKER LEVEL | 1 |
| CLOSED CAPTION | ▶ | MARKER MAT | OFF |
| CONFIG | ▶ | CROSS HATCH | OFF |
| COLOR TEMP | ▶ | | |
| FUNCTION KEY | ▶ | | |
| GPI | ▶ | | |
| IMD | ▶ | | |
| KEY INHIBIT | ▶ | | |

Figure 5.1-10 MARKER Menu

The relationship of Items, Default Value, Domain Range and Description of the sub-item is shown in Table 5.1-3:

Table 5.1-3 The Description of MARKER Menu Items

| Items | Default Value | Domain Range | Description |
|-------------|---------------|--|--|
| MARKER | OFF | OFF/ON | Set whether to show all of the markers. It is the main switch for area marker, center marker and safety marker. |
| AREA MARKER | OFF | when the display aspect is 16:9, images show with the following scale: | Select the area marker aspect ratio according to the display aspect ratio. |

| Items | Default Value | Domain Range | Description |
|---------------|---------------|--|--|
| | | <ul style="list-style-type: none"> • OFF: close area marker • 4:3 • 15:9 • 14:9 • 13:9 • 1.85:1 • 2.35:1 when the display aspect is 4:3, images show with the following scale: <ul style="list-style-type: none"> • OFF: close area marker • 16:9 | |
| CENTER MARKER | OFF | OFF/ON | Set whether to show the center marker |
| SAFETY MARKER | OFF | <ul style="list-style-type: none"> • OFF • 80% • 85% • 88% • 90% • 93% • 95% | Set the safety area size according to the aspect ratio and scan mode. |
| MARKER LEVEL | 1 | <ul style="list-style-type: none"> • 1: 50% • 2: 75% • 3: 100% | Set the luminance of marker line, including safety marker, center marker, area marker and cross hatch. |
| MARKER MAT | OFF | <ul style="list-style-type: none"> • OFF: Normal background, use line for area marker edge only • HALF: 50% Background brightness • BLACK: all black | Set the transparency of area marker mat. |
| CROSS HATCH | OFF | OFF/ON | Set whether to show the cross hatch. |

■ Markers

| Marker | Illustration | Description |
|---------------|--------------|--|
| CENTER MARKER | | This marker enables easier checking the center portion's focus. |
| AREA MARKER | | This marker displays two lines to identify an area with a specified ratio. |
| SAFETY MARKER | | This marker displays a rectangle to identify the safety area with a specified percentage. |
| CROSS HATCH | | This marker displays multiple vertical and horizontal lines to help when users check the composition of a picture. |

■ MARKER MAT

The marker mat marks the outside area of the marker display with the appointed transparency.

For example, set ASPECT as 16:9, AREA MARKER as 4:3, and SAFETY AREA as 95%, then, the comparison of the three MARKER MATs are as shown in Figure 5.1-11:



Figure 5.1-11 MARKER MAT

i Tips

- All markers will be hidden in the following modes though the corresponding marker is enabled (the value is not OFF): NATIVE, H/V DELAY, PBP.

- The AREA MARKER, CENTER MARKER and SAFETY MARKER feature are available only when the MARKER item is set to ON.
- The safety marker area will change with the area marker.
- The cross hatch lines will display only in the single image or in PIP mode when **CROSS HATCH** is **ON**.

5.1.4 AUDIO Menu

The AUDIO menu items are used to adjust the audio parameters, the menu items are as shown in Figure 5.1-12:

| MAIN | | AUDIO | |
|----------------|---|-----------------|------------|
| STATUS | ▶ | AUDIO SOURCE | AUDIO1 |
| INPUT SELECT | ▶ | SPEAK OUT L | EBD CH1 |
| MARKER | ▶ | SPEAK OUT R | EBD CH1 |
| AUDIO | ▶ | AUDIO METER | OFF |
| DISPALY | ▶ | METER SELECT | CH1-2 |
| CLOSED CAPTION | ▶ | METER DIRECTION | HORIZONTAL |
| CONFIG | ▶ | METER POSITION | TOP |
| COLOR TEMP | ▶ | METER DIS MODE | MODE1 |
| FUNCTION KEY | ▶ | REF LEVEL | -20dB |
| GPI | ▶ | OVER LEVEL | -10dB |
| IMD | ▶ | | |
| KEY INHIBIT | ▶ | | |

Figure 5.1-12 AUDIO Menu

The relationship of Items, Default Value, Domain Range and Description of the sub-item is shown in Table 5.1-4:

Table 5.1-4 The Description of AUDIO Menu Items

| Items | Default Value | Domain Range | Description |
|--------------|---------------|--|---|
| AUDIO SOURCE | EBD | <ul style="list-style-type: none"> • EBD: embedded signal • AUDIO1: external signal1 • AUDIO2: external signal2 | Select the audio source. When there is no sync in and the input signal is not HDMI/SDI1/SDI2, you can select only |

| Items | Default Value | Domain Range | Description |
|-----------------|---------------------|---|--|
| | | <ul style="list-style-type: none"> UNDEF: no signal | UNDEF, AUDIO1 or AUDIO2. |
| SPEAK OUT L | EBD CH1 | When the audio source is EBD, the range of this item is EBD CH1~ EBD CH16. | Left speaker, select a channel according to the type of audio source. |
| SPEAK OUT R | EBD CH2 | When the audio source is EBD, the range of this item is EBD CH1~ EBD CH16. | Right speaker, select a channel according to the type of audio source. |
| AUDIO METER | OFF | OFF/ON | Set whether to display the audio meter. |
| METER SELECT | CH1-2 | <ul style="list-style-type: none"> CH1-2 G1 G2 G3 G4 G1+G2 G1+G3 G1+G4 G2+G3 G2+G4 G3+G4 G1-G4 | Select a meter display mode. Each G* contains four channels, and each CH* means a channel with number. |
| METER DIRECTION | VERTICAL | <ul style="list-style-type: none"> VERTICAL HORIZONTAL | Select the displayed direction of audio meter. |
| METER POSITION | BOT LEFT/ BOTTOM | <p>When the value of METER DIRECTION is VERTICAL , you can choose the followings for Meter Position:</p> <ul style="list-style-type: none"> BOT LEFT: bottom left BOT RIGHT: bottom right TOP RIGHT: top right TOP LEFT: top left <p>When the value of METER DIRECTION is HORIZONTAL, you can choose the followings for Meter Position:</p> <ul style="list-style-type: none"> BOTTOM TOP | Select the displayed position of audio meter. |
| METER DIS MODE | MODE1 | <ul style="list-style-type: none"> MODE1: simple audio meter | Select the displayed mode for audio meter. |

| Items | Default Value | Domain Range | Description |
|------------|---------------|---|----------------------------|
| | | <ul style="list-style-type: none"> MODE2: audio meter with channel number MODE3: audio meter with channel number and dB value | |
| REF LEVEL | -20dB | -20dB/-18dB | Select the reference level |
| OVER LEVEL | -10dB | <ul style="list-style-type: none"> -10dB -8dB -6dB -4dB -2dB | Select the overload level |

The appearance of Meter is as shown in Figure 5.1-13:

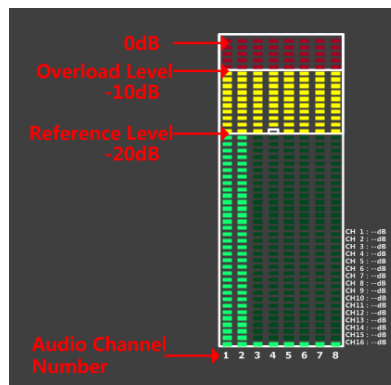

Figure 5.1-13 Audio Meter

- METER SELECT** and **METER DIS MODE** control the operational characteristics of Audio Metering, the former controls the amount of channels displayed in a meter.

As shown in Figure 5.1-14, the meter displays at the left of the screen vertically, the **METER SELECT** is **G1+G2**, and the **METER DIS MODE** is **MODE3**, you can see the meter displays audio channel numbers and audio values beside the meter. There is a white rectangle frame with two white level lines in the meter, the upper is the over level line, and the lower is the reference level line. If the audio value is higher than the reference level, the audio bar over the reference level line will display yellow, and if the audio value is higher than the over level, the audio bar over the over level line will display red.



Figure 5.1-14 The Position of the Audio Meter On Screen

- The position of Meter is controlled by **METER DIRECTION** and **METER POSITION**, the position of the meter on the screen is as follows: BOT LEFT VERTICAL, BOT RIGHT VERTICAL, TOP LEFT VERTICAL, TOP RIGHT VERTICAL, BOTTOM HORIZONTAL and TOP HORIZONTAL. For example, the illustrations of some of the positions are as shown in Figure 5.1-15:

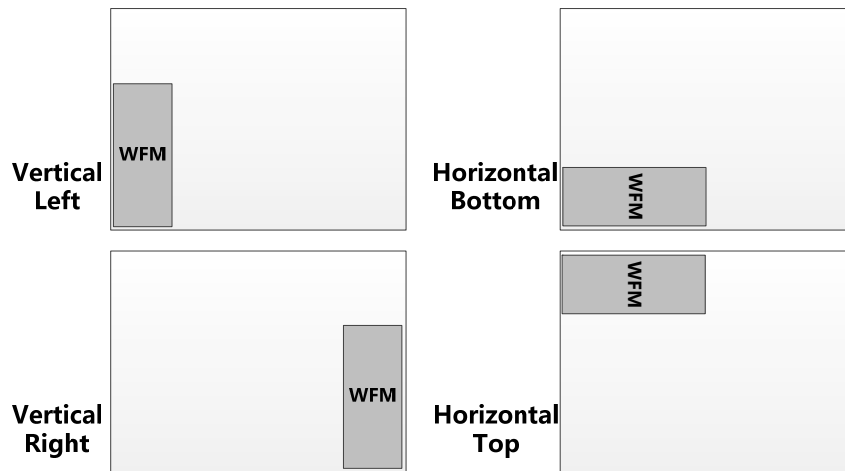

Figure 5.1-15 the Positions of Meter

- Particularly, if the **METER SELECT** is **G1-4**, there will be 16 channels displayed in audio meter, and if the **METER DIRECTION** is **Horizontal**, the audio meter will display two meters separately on both sides of the screen. One displays 8 channels(1~8) on the bottom or top left of the screen, and the other displays 8 channels(9~16) on the bottom or top right of the screen, the bottom or top is decided by **METER POSITION**, as shown in Figure 5.1-16:

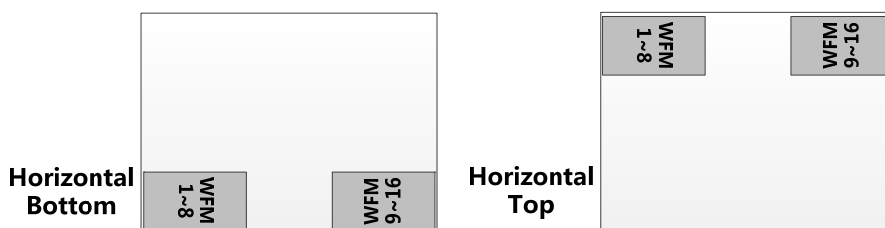

Figure 5.1-16 the Positions of the 16-channels Meter

- The prerequisite for the available settings of the display mode and the position of audio meter is that the **AUDIO METER** is **ON**.

5.1.5 DISPLAY Menu

The DISPLAY menu items are used to adjust the parameters displayed on the screen, the menu items are as shown in Figure 5.1-17:

| MAIN | DISPLAY |
|----------------|--------------------------|
| STATUS | STATUS DISPLAY AUTO |
| INPUT SELECT | AFD DISPLAY OFF |
| MARKER | WAVE FORM TYPE WAVE FORM |
| AUDIO | LINE WAVE OFF |
| DISPALY | LINE WAVE NUMBER --- |
| CLOSED CAPTION | WAVE OVER LIMIT 50 |
| CONFIG | WAVE UNDER LIMIT 0 |
| COLOR TEMP | WFM TRANS OPAQUE |
| FUNCTION KEY | WFM POSITION LEFT |
| GPI | TIME CODE OFF |
| IMD | |
| KEY INHIBIT | |

Figure 5.1-17 DISPLAY SETUP Menu

The relationship of Items, Default Value, Domain Range and Description of the sub-item is shown in Table 5.1-5:

Table 5.1-5 The Description of DISPLAY SETUP Menu Items

| Items | Default Value | Domain Range | Description |
|----------------|---------------|--------------|---|
| STATUS DISPLAY | AUTO | OFF/ON/AUTO | Set whether to display STD information. If the signal input is not equal to "No signal" and this item is auto, the status information will show 15 seconds when the status changed, and then closed automatically. |

| Items | Default Value | Domain Range | Description |
|------------------|---------------|---|--|
| AFD DISPLAY | OFF | OFF/ON | Set whether to display AFD information. ON is an effective value to AFD DISPLAY item only if the value of STATUS DISPLAY is AUTO or ON. |
| WFM FORM TYPE | NORMAL | <ul style="list-style-type: none"> • MODE1 • MODE2 • VECT100 • VECT75 • WAVE FORM • OFF | Switch the display mode among mode1, mode2, vector100, vector75 and wave form. |
| LINE WAVE | OFF | OFF/ON | Set whether to show line wave, as shown in Figure 5.1-18. |
| LINE WAVE NUMBER | 260 | As shown in Table 5.1-6. | Set the position of line WFM. |
| WFM OVERLIMIT | 50 | 50~100 | Set the over limit of WFM |
| WFM UNDERLIMIT | 0 | 0~50 | Set the under limit of WFM |
| WFM TRANS | OPAQUE | <ul style="list-style-type: none"> • OPAQUE • TRANS1 • TRANS2 • TRANS3 | Set the transparency of the WFM |
| WFM POSITION | LEFT | <ul style="list-style-type: none"> • LEFT: LEFT BOT • RIGHT: BOT RIGHT | Select the displayed position for WFM. |
| TIME CODE | OFF | <ul style="list-style-type: none"> • OFF • D-VITC • LTC • VITC | Set whether to display TC, and select a mode for TC display. |

Thereinto, the value of LINE WFM is different according to the type of input signal, as shown in Table 5.1-6.

Table 5.1-6 The Description for LINE WFM Item

| Input Signal | Default | Domain Range |
|--------------|---------|--------------|
| 576i50 | 310 | 23~623 |

| Input Signal | Default | Domain Range |
|----------------|---------|--------------|
| 480i60 | 261 | 22~524 |
| 720p | 386 | 26~745 |
| 1080i50 | 560 | 21~1123 |
| 1080i60/59.94 | | |
| 1080sf23/23.97 | | |
| 1035i60 | 557 | 41~1120 |
| 1080p | 561 | 42~1121 |

The comparison of a normal WFM/Vector and a Line WFM is as shown in Figure 5.1-18:

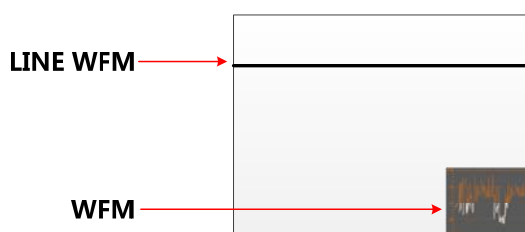

Figure 5.1-18 The LINE WFM and the WFM

Tips

- You can call out the vectorscope or wave form and configure its display mode through **DISPLAY→WAVE FORM TYPE**, and configure its display position through **DISPLAY →WFM POSITION**.
- Please refer to the international standard SMPTE2016-1-2007 for the details about AFD display.

5.1.6 CLOSED CAPTION Menu

The CLOSED CAPTION menu items are used to set whether to display closed caption on screen and set the display mode, the menu items are as shown in Figure 5.1-19:

| MAIN | | CLOSED CAPTION | |
|-----------------------|---|-----------------|-------|
| STATUS | ▶ | SDI CC LOG | OFF |
| INPUT SELECT | ▶ | CLOSED CAPTION | OFF |
| MARKER | ▶ | SDI CC TYPE | AUTO1 |
| AUDIO | ▶ | 608 CHANNEL SEL | CC1 |
| DISPALY | ▶ | | |
| CLOSED CAPTION | ▶ | | |
| CONFIG | ▶ | | |
| COLOR TEMP | ▶ | | |
| FUNCTION KEY | ▶ | | |
| GPI | ▶ | | |
| IMD | ▶ | | |
| KEY INHIBIT | ▶ | | |

Figure 5.1-19 CLOSED CAPTION Menu

The relationship of Items, Default Value, Domain Range and Description of the sub-item is shown in Table 5.1-7:

Table 5.1-7 The Description of CLOSE CAPTION Menu Items

| Items | Default Value | Domain Range | Description |
|----------------|---------------|--|---|
| SDI CC LOG | OFF | OFF/ON | Set whether to display CC information. |
| CLOSED CAPTION | OFF | OFF/ON | Set whether to display caption information. |
| SDI CC TYPE | AUTO1 | <ul style="list-style-type: none"> AUTO1: Select to set to 608(VBI) when the SD-SDI signal is input or 608(708) when the HD-SDI signal is input. AUTO2: Select to set to 608(ANC) when the SD-SDI signal is input or 608(708) when the HD-SDI signal is input. 608(708): Select to display the closed caption signal transmitted by EIA/CEA-708 standards. 608(ANC): Select to display the closed caption signal transmitted by EIA/CEA-608 or | Set the closed caption type. |

| Items | Default Value | Domain Range | Description |
|-----------------|---------------|---|--|
| | | EIA/CEA-708 standards. <ul style="list-style-type: none"> • 608(VBI): Select to display the closed caption signal of the EIA/CEA-608 standards transmitted by using the line 21. | |
| 608 CHANNEL SEL | CC1 | <ul style="list-style-type: none"> • CC1 • CC2 • CC3 • CC4 • TEXT1 • TEXT2 • TEXT3 • TEXT4 | Set the display mode for closed caption for 608(708), 608(ANC) and 608(VBI). |

5.1.7 CONFIG Menu

The CONFIG menu items are used to adjust the parameters defined by customers, the menu items are as shown in Figure 5.1-20:

| MAIN | CONFIG |
|------------------|-------------------------|
| STATUS ▶ | FAST MODE OFF |
| INPUT SELECT ▶ | FILM MODE DETECT OFF |
| MARKER ▶ | SUB IN TYPE PBP |
| AUDIO ▶ | SUB IN SELECT SDI1 |
| DISPALY ▶ | PIP SIZE LARGE |
| CLOSED CAPTION ▶ | PIP POSITION HORIZONTAL |
| CONFIG ▶ | BACKLIGHT 15 |
| COLOR TEMP ▶ | AUTO STANDBY OFF |
| FUNCTION KEY ▶ | APPEATURE 0 |
| GPI ▶ | LOCK NUMBER XXXXXXXX |
| IMD ▶ | LANGUAGE ENGLISH |
| KEY INHIBIT ▶ | H FLIP OFF |

Figure 5.1-20 CONFIG Menu

The relationship of Items, Default Value, Domain Range and Description of the sub-item is shown in Table 5.1-8:

Table 5.1-8 The Description of CONFIG Menu Items

| Items | Default Value | Domain Range | Description |
|---------------------|---------------|--|---|
| FAST MODE | OFF | OFF/ON | Set whether in fast mode. |
| FILM MODE DETECT | OFF | OFF/ON | Set whether to detect film mode. |
| SUB IN TYPE | PBP | PBP/PIP/OFF | Set the arrangement mode of screen picture |
| SUB IN SELECT | SDI1 | <ul style="list-style-type: none"> • SDI1 • SDI2 • LINE1(CVBS) • LINE2(CVBS) • LINE2(Y/C) • LINE2(YPBPR) • HDMI | Set the source of slave picture, refer to Table 5.1-10 for the details. |
| PIP SIZE | LARGE | SMALL/LARGE | Set the size of PIP |
| PIP POSITION | BOT LEFT | <ul style="list-style-type: none"> • BOT LEFT: bottom left • BOT RIGHT: bottom right • TOP RIGHT • TOP LEFT | Set the position of PIP |
| BACK LIGHT | 15 | 0~30 | Adjust the back light |
| AUTO STANDBY | OFF | OFF/ON | Set whether open the standby mode. |
| APPERTURE | 0 | 0~24 | Set the picture sharpness |
| LOCK NUMBER | XXXXXXXX | -- | Set the lock number |
| LANGUAGE | ENGLISH | ENGLISH/CHINESE | Select a language mode |
| H FLIP | OFF | OFF/ON | Set whether to set signals to be inverted horizontally and displayed. |

1. Display Multiple Images

This monitor allows simultaneous display of two input signals on the monitor's screen. It will introduce the display mode, settings and signal source selection for the multiple images on screen as follows.

(1) Display Mode

This device provides four modes for picture & picture display: PIP, PBP, and the relevant relationship of the two pictures are as shown in Figure 5.1-21:



Figure 5.1-21 Multiple Inputs

■ **PIP** (Picture in Picture)

The two pictures generated by two input signals separately are displayed one in another. One is displayed on full screen, called as the main picture, and the other is displayed in an inset window, called as the slave picture. In PIP mode, the relevant position relationship of the main picture and the slave picture is as shown in Figure 5.1-22:

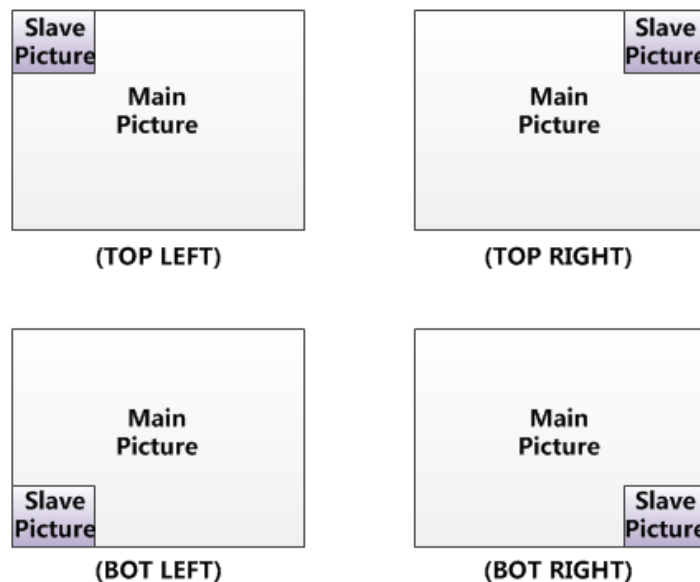

Figure 5.1-22 The Position Relationship in PIP Mode

And you can adjust the display size by the **PIP SIZE** item, and there are two kinds of outlines for the slave picture, as shown in Figure 5.1-23:

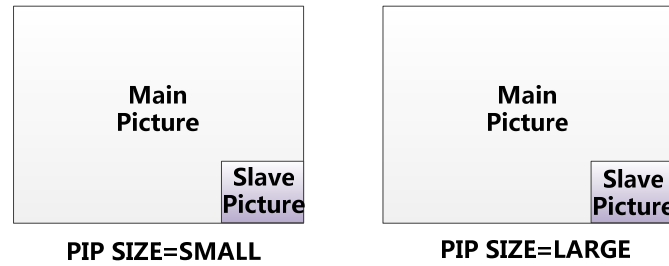

Figure 5.1-23 The Size for the Slave Picture

In PIP mode, it displays the WFM or Audio Meter only for the signal source of the main picture, and if the WFM is set as displayed, the Audio Meter will be display only at the top position(Top left or Top right) at the screen. For example, the WFM displays at the bottom left, and the Audio Meter could be only displayed at the top position in case of collision, as shown in Figure 5.1-24:

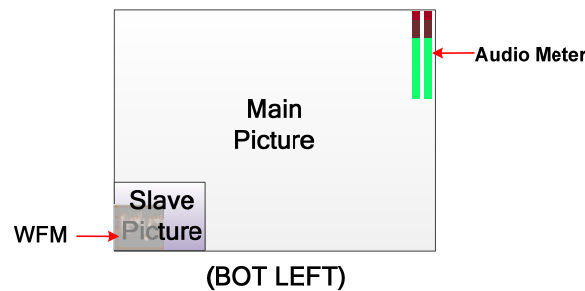

Figure 5.1-24 The Illustrate for WFM and Audio Meter Display

■ **PBP(Picture by Picture)**

The two pictures generated by two input signals separately are displayed side by side, and this function helps with white balance adjustment, and determining shooting angles between two cameras etc. In PBP mode, the size of the main picture is as large as the slave picture's, and the position relationship of the main picture and the slave picture is as shown Figure 5.1-25:

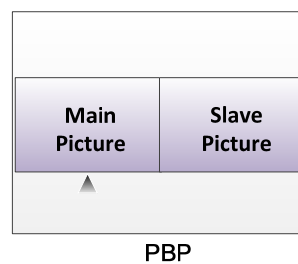

Figure 5.1-25 PBP Mode

In PBP mode, it displays the WFM or Audio Meter only for the signal of the current picture. The current picture is labeled by a triangle, as shown in Figure 5.1-26, at the bottom center of the picture. You can select the current picture by the **WIN SELECT** command assigned to a function key.

When the main picture is set as the current picture, and the WFM is set as displayed, the WFM could only be displayed at the left bottom of the screen, as shown in Figure 5.1-26, and meantime, the Audio Meter will be display only at the top position (Top left or Top right) at the screen in case of collision.

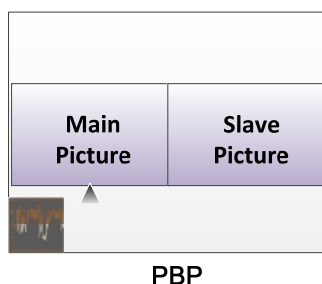

Figure 5.1-26 Position Relationship of WFM and the Current Picture

When the slave picture is set as the current picture, and the WFM is set as displayed, the WFM could only be displayed at the right bottom of the screen, as shown in Figure 5.1-27, and meantime, the Audio Meter will be display only at the top position (Top left or Top right) at the screen in case of collision.

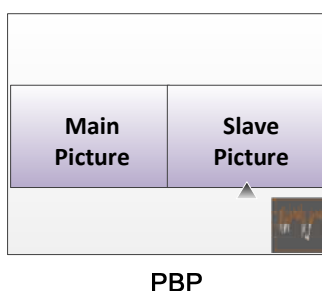

Figure 5.1-27 Position Relationship of WFM and the Current Picture

(2) Set Display Mode

The selection for picture & picture display mode contains the following items: OFF, PBP, PIP, you can switch the selection as instructed below:

■ Method 1: By menu item.

Select the menu item **Config** → **SUB IN TYPE**, use **ENTER**, **UP** or **DOWN** key to select a display mode.

- Method 2: By function key.

Set **PBP** function to a function key (F1~F5). Select the menu item **FUNCTION KEY → F1** for example, and assign its sub-item value as PBP, as shown in **Figure 5.1-28**:

| FUNCTION | | |
|----------|------------|--------|
| F1 | PBP | PBP |
| F2 | NATIVE | OFF |
| F3 | ASPECT | 4:3 |
| F4 | WIN SELECT | MAIN |
| F5 | SCAN | NORMAL |

Figure 5.1-28 Set the Function Key as PBP

(3) Scope for the signal source of the slave picture

The selection scope of the signal source for the slave picture will be changing with the main picture's source, as shown in Table 5.1-9:

Table 5.1-9 The Relationship of the Signal Source for Slave Picture and Main Picture

| Signal Source for Main Picture \ Signal Source for Slave Picture | SDI1 | SDI2 | LINE1 (CVBS) | LINE2 (CVBS) | LINE2 (Y/C) | LINE2 (YPSPR) | HDMI |
|--|------|------|--------------|--------------|-------------|---------------|------|
| SDI1 | × | ✓ | ✓ | ✓ | ✓ | ✓ | ✓ |
| SDI2 | ✓ | × | ✓ | ✓ | ✓ | ✓ | ✓ |
| LINE1(CVBS) | ✓ | ✓ | × | × | × | × | ✓ |
| LINE2(CVBS) | ✓ | ✓ | × | × | × | × | ✓ |
| LINE2(Y/C) | ✓ | ✓ | × | × | × | × | ✓ |
| LINE2(YPBPR) | ✓ | ✓ | ✓ | ✓ | × | × | ✓ |
| HDMI | ✓ | ✓ | ✓ | ✓ | ✓ | ✓ | × |

i Tips

- Select input source format for LINE2: For the LINE2(CVBS) interface, the LINE2(Y/C) interface and the LINE2(YPSPR) interface share the same group of physical interfaces, select the signal source format for LINE2 according to the line connection mode. When select a signal source format for LINE2, you can set the menu item **INPUT SELECT → LINE2** as CVBS,

LINE2(Y/C) or LINE2(YPBPR), in addition, press INPUT button to pop up the source list for LINE2 selection.

- **Position for signal source:** The input signal information of the main picture displays at the top left corner of the screen, and the one of the slave picture displays at the top right corner of the screen.
- **Settings for signal source:** Press **INPUT** button to set the signal source for the main picture, and select **CONFIG**→**SUB IN TYPE** menu item to set the signal source for the slave picture.

2. Set H FLIP MODE

- H FLIP Mode

The input signal has been inverted horizontally by a mirror type in H FLIP Display mode.

Select the menu item **CONFIG** →**H FLIP** to be set to **ON**, thus to inverse these inputs horizontally.

The display result in the **Horizontal FLIP MODE** is as shown in **Figure 5.1-29**:



Figure 5.1-29 Horizontal Flip Mode

Tips

- The Wave Form of the input signal in **H FLIP** mode will not be inverted horizontally.

3. Auto Standby

The Auto Standby function is used to set the status of the monitor when the Power button is turned on or off.

- **ON: AUTO STANDBY** is set to **ON** to enable the auto standby mode. Thus, the auto standby will be activated when detecting no signal input or signal disappeared, and there will be a prompt during the process, as shown in **Figure 5.1-30**:



Going into Standby Mode

Figure 5.1-30 Entering the Auto Standby Mode

When detecting no signal input or signal disappeared, the power indicator will be lit in flash green for 10 seconds, and showing the standby prompt, after that, the monitor screen will be turned off, and it will be in auto standby mode, the POWER indicator is lit in green. Then, if the signal input is correct, the monitor screen will be lit up automatically.

- **OFF: AUTO STANDBY** is set to **OFF** to disable the auto standby mode.

Press **POWER** button when the monitor is in operation mode, it will power off the monitor, otherwise, press **POWER** button when the monitor is off, thus it will power on the monitor, and the **POWER** indicator is lit in green.

Tips

- The length of LOCK NUMBER is up to 8 characters, you can use the combination of these characters: number (0 to 9) and letter (A to Z). Press **ENTER** to edit the LOCK NUMBER, than use **UP** or **DOWN** to select characters, than press **ENTER** to go to next character, press **MENU** to exit editor.
-

5.1.8 COLOR TEMP Menu

The COLOR TEMP menu items are used to adjust the color temperature parameters and the color balance, the menu items are as shown in Figure 5.1-31:

| MAIN | | COLOR TEMP | |
|-------------------|---|-------------|------|
| STATUS | ▶ | COLOR TEMP | D65 |
| INPUT SELECT | ▶ | RED GAIN | 128 |
| MARKER | ▶ | GREEN GAIN | 128 |
| AUDIO | ▶ | BLUE GAIN | 128 |
| DISPALY | ▶ | RED BIAS | 0 |
| CLOSED CAPTION | ▶ | GREEN BIAS | 0 |
| CONFIG | ▶ | BLUE BIAS | 0 |
| COLOR TEMP | ▶ | COPY FROM | D65 |
| FUNCTION KEY | ▶ | RESET | |
| GPI | ▶ | COLOR SPACE | AUTO |
| IMD | ▶ | | |
| KEY INHIBIT | ▶ | | |

Figure 5.1-31 COLOR TEMP Menu

The relationship of Items, Default Value, Domain Range and Description of the sub-item is shown in Table 5.1-10:

Table 5.1-10 The Description of COLOR TEMP Menu Items

| Items | Default Value | Domain Range | Description |
|------------|---------------|--|-----------------------------------|
| COLOR TEMP | D65 | <ul style="list-style-type: none"> • USER1: Customized by user • USER2: Customized by user • D32: 3200K • D50: 5000K • D56: 5600K • D65: 6500K • D93: 9300K | Set color temperature |
| RED GAIN | 128 | 0~256 | Adjust the Red Gain |
| GREEN GAIN | 128 | 0~256 | Adjust the Green Gain |
| BLUE GAIN | 128 | 0~256 | Adjust the Blue Gain |
| RED BIAS | 0 | -127~127 | Adjust the Red Offset |
| GREEN BIAS | 0 | -127~127 | Adjust the Green Offset |
| BLUE BIAS | 0 | -127~127 | Adjust the Blue Offset |
| COPY FROM | D65 | <ul style="list-style-type: none"> • D32: 3200K • D50: 5000K | Copy this parameter value to USER |

| Items | Default Value | Domain Range | Description |
|-------------|---------------|--|---|
| | | <ul style="list-style-type: none"> D56: 5600K D65: 6500K D93: 9300K | |
| RESET | -- | -- | Reset the Gain and Offset values to the product originals |
| COLOR SPACE | EBU | OFF/EBU/SMPTE-C/ITU-709/AUTO/USER | Select the color matrix |

i Tips

- The items about RED/GREEN/BLUE GAIN and BIAS are available only in USER1 and USER2 mode. If the COLOR TEMP is set to **USER1** or **USER2** with customized settings, you can select the menu item **COLOR TEMP** → **RESET** command to restore product originals for Gains and Offsets, and press **ENTER** button to confirm the reset operation.

5.1.9 FUNCTION KEY Menu

The FUNCTION KEY menu items are used to assign function to the function key (F1~F5) on the front panel, and adjust the value of the function parameter. The menu items of FUNCTION KEY are as shown in Figure 5.1-32:

| MAIN | FUNCTION KEY |
|-----------------------|--------------|
| STATUS ▶ | F1 SCAN |
| INPUT SELECT ▶ | F2 NATIVE |
| MARKER ▶ | F3 ASPECT |
| AUDIO ▶ | F4 OFF |
| DISPALY ▶ | F5 OFF |
| CLOSED CAPTION ▶ | |
| CONFIG ▶ | |
| COLOR TEMP ▶ | |
| FUNCTION KEY ▶ | |
| GPI ▶ | |
| IMD ▶ | |
| KEY INHIBIT ▶ | |

Figure 5.1-32 FUNCTION KEY Menu

The relationship of Items, Default Value, Domain Range and Description of the sub-item is shown in Table 5.1-11:

Table 5.1-11 The Description of FUNCTION KEY Menu Items

| Items | Default Value | Domain Range | Description |
|-------|---------------|--|-----------------------------|
| F1 | SCAN | SCAN, NATIVE, ASPECT, BLUE ONLY, MONO, MARKER, H/V DELAY, AUDIO METER, FAST MODE, TC, IMD, MUTE, PBP, CC, FREEZE, WIN SELECT, FOCUS ASSIST, LUMA ZOOM CHECK, H FLIP, UNDEF | Set a function to F1 button |
| F2 | NATIVE | the same as F1 | Set a function to F2 button |
| F3 | ASPECT | the same as F1 | Set a function to F3 button |
| F4 | UNDEF | the same as F1 | Set a function to F4 button |
| F5 | UNDEF | the same as F1 | Set a function to F5 button |

1. SCAN

This product supports the following scan modes:

NORMAL → OVER → UNDER

Set the function button as [SCAN], press the button continuously to activate various scan modes.

- OVER: Zooms in/out of the image to 96% of its original size without changing the aspect ratio.
- NORMAL: Zooms in/out of the image without changing the aspect ratio.
- UNDER: Zooms in/out of the image without changing the aspect ratio. Also, displays the data at the top of the horizontal blanking block.

2. ASPECT

Set the aspect ratio of the screen, it is different from the formats of the input signals, and the details are as shown in Table 5.1-12:

Table 5.1-12 The Relationship of Input Signal Formats and Its Aspects

| Input Signal | Default | Value Range | Input Signal Formats | |
|--------------|---------|---|--|---|
| SD | 4:3 | <ul style="list-style-type: none"> 4:3 16:9 | PAL NTSC 480I60/59.94 | 576I50 480P60/59.94 576P50 |
| HD | 16:9 | <ul style="list-style-type: none"> 16:9 2.39:1 | 720P24/23.97 720P25 720P30/29.97 720P50 720P60/59.94 1080SF24/23.97 1035I60/59.94 | 1080I50 1080I60/59.94 1080P24/23.97 1080P25 1080P30/29.97 1080P50 1080P60/59.94 |
| 2K | 1.896:1 | <ul style="list-style-type: none"> 1.896:1 2.39:1 | 2048X1080PSF24/23.97 2048X1080PSF25 2048X1080PSF30/29.97 2048X1080P24/23.97 2048X1080P25 | 2048X1080P30/29.97 2048X1080P48/47.94 2048X1080P50 2048X1080P60/59.94 |

3. FREEZE

Active this function to freeze the current frame displayed, press the function button again to release the freeze and continue to display.

4. BLUE ONLY

It is to activate BLUE ONLY mode that will remove red and green from the input signal and display the screen only under a blue signal.

5. MONO

It is to activate MONO mode that will display the screen in monochrome presentation, inactivate this mode to display the screen in color mode.

Tips

- Press F1~F5 button to activate the assigned function and adjust the parameter value.
- The **SCAN** mode or the **ASPECT** mode is not selectable when Native mode is set to ON.
- Particularly, when the **PBP** function is assigned to a function key, press this function key to select the display mode for picture & picture display.

5.1.10 GPI Menu

The GPI menu items are used to define functions to GPI1~GPI6, the

menu items are as shown in Figure 5.1-33:

| MAIN | | GPI | |
|----------------|---|------|-------------|
| STATUS | ▶ | GPI1 | TALLY GREEN |
| INPUT SELECT | ▶ | GPI2 | TALLY RED |
| MARKER | ▶ | GPI3 | NATIVE |
| AUDIO | ▶ | GPI4 | BLUE ONLY |
| DISPALY | ▶ | GPI5 | MONO |
| CLOSED CAPTION | ▶ | GPI6 | H/V DELAY |
| CONFIG | ▶ | | |
| COLOR TEMP | ▶ | | |
| FUNCTION KEY | ▶ | | |
| GPI | ▶ | | |
| IMD | ▶ | | |
| KEY INHIBIT | ▶ | | |

Figure 5.1-33 GPI Menu

The relationship of Items, Default Value, Domain Range and Description of the sub-item is shown in Table 5.1-13:

Table 5.1-13 The Description of GPI Menu Items

| Items | Default Value | Domain Range | Description |
|-------|---------------|---|------------------------|
| GPI1 | TALLY GREEN | UNDEF, AREA MARKER, CENTER MARKER, SAFETY MARKER, ASPECT, NATIVE, OVER SCAN, UNDER SCAN, BLUE ONLY, MONO, H DELAY, V DELAY, H/V DELAY, SDI1, SDI2, LINE1, LINE2, HDMI, TALLY GREEN, TALLY RED | Set a function to GPI1 |
| GPI2 | TALLY RED | the same as GPI1 | Set a function to GPI2 |
| GPI3 | UNDEF | the same as GPI1 | Set a function to GPI3 |
| GPI4 | UNDEF | the same as GPI1 | Set a function to GPI4 |
| GPI5 | UNDEF | the same as GPI1 | Set a function to GPI5 |
| GPI6 | UNDEF | the same as GPI1 | Set a function to GPI6 |

Tips

- Assign functions to GPI1~GPI6, some is level triggered, and some is edge

triggered, refer to Table 5.1-14 for the details.

- GPI control: when it changes it would be as a control value of response control. If the level does not change, but there are other control caused by changes in the control value, perform this change. When boot, detect the GPI input status after initialization. If a GPI value is low, the monitor will control the corresponding operation. The TALLY is directly control by the level.

Table 5.1-14 The Description for GPI Items and Their Trigger

| Items | Function | Trigger |
|---------------|--|--|
| AREA MARKER | Enable/Disable the display of area marker. | Low: Enabled; High: Disabled |
| CENTER MARKER | Enable/Disable the display of center marker. | Low: Enabled; High: Disabled |
| SAFETY MARKER | Enable/Disable the display of safety marker. | Low: Enabled; High: Disabled |
| ASPECT | Set the aspect ratio. | Low: 16:9; High: 4:3 |
| MONO | Switch between the monochrome and color. | Low: MONO; High: NORMAL |
| OVER SCAN | Switch scan mode between over and normal. | Low: OVER; High: NORMAL |
| UNDER SCAN | Switch scan mode between under and normal. | Low: UNDER; High: NORMAL |
| BLUE ONLY | Switch between blue only and normal. | Low: BLUE ONLY; High: NORMAL |
| NATIVE | Switch between native and normal. | Low: NATIVE(In center); High: NORMAL |
| H DELAY | Switch between H delay and normal. | Low: H DELAY; High: NORMAL |
| V DELAY | Switch between V delay and normal. | Low: V DELAY; High: NORMAL |
| H/V DELAY | Switch between H/V delay and normal. | Low: H/V DELAY; High: NORMAL |
| SDI1 | Switch the input source to SDI1. | Switch at the falling edge, when switching to the other input, exit. |

| Items | Function | Trigger |
|-------------|-----------------------------------|--|
| SDI2 | Switch the input source to SDI2. | Switch at the falling edge, when switching to the other input, exit. |
| LINE1 | Switch the input source to LINE1. | Switch at the falling edge, when switching to the other input, exit. |
| LINE2 | Switch the input source to LINE2. | Switch at the falling edge, when switching to the other input, exit. |
| HDMI | Switch the input source to HDMI. | Switch at the falling edge, when switching to the other input, exit. |
| TALLY GREEN | Light the green tally. | Low: ON; High: OFF |
| TALLY RED | Light the red tally. | Low: ON; High: OFF |

5.1.11 IMD Menu

The IMD menu items are used to adjust the parameters defined for IMD display, the menu items are as shown in Figure 5.1-34:

| MAIN | IMD |
|------------------|------------------------------------|
| STATUS ▶ | IMD DISPLAY ON |
| INPUT SELECT ▶ | IMD COLOR RED |
| MARKER ▶ | IMD CHARACTER XXXXXXXXXXXXXXXXXXXX |
| AUDIO ▶ | IMD PROTOCOL LOCAL |
| DISPALY ▶ | IMD ID 0 |
| CLOSED CAPTION ▶ | IMD NAME XXXXXXXXXXXXXXXXXXXX |
| CONFIG ▶ | BAUD RATE 38400 |
| COLOR TEMP ▶ | LED TALLY OFF |
| FUNCTION KEY ▶ | OSD TALLY MODE RG |
| GPI ▶ | IMD TALLY MODE T1 |
| IMD ▶ | TALLY SOURCE STANDARD |
| KEY INHIBIT ▶ | |

Figure 5.1-34 IMD Menu

The relationship of Items, Default Value, Domain Range and Description of the sub-item is shown in Table 5.1-15:

Table 5.1-15 The Description of IMD Menu Items

| Items | Default Value | Domain Range | Description |
|----------------|---------------|---|---|
| IMD DISPLAY | ON | OFF/ON | Set whether to display IMD CHARACTER on screen. |
| IMD COLOR | RED | <ul style="list-style-type: none"> • RED • GREEN • YELLOW • WHITE | Set the color for IMD CHARACTER. |
| IMD CHARACTER | XXXXXXXX | -- | Set the IMD string displayed on the screen. After entering this item, press Up or Down to choose your character for this IMD string. |
| IMD PROTOCOL | LOCAL | <ul style="list-style-type: none"> • LOCAL • TSL3.1 • TSL4.0 • TSL5.0 • IMAGE VIDEO • NETWORK | Select an IMD protocol |
| IMD ID | 0 | 0~255 | Set the ID number for each monitor |
| IMD NAME | XXXXXXXX | | Set an IMD name for each screen. |
| BAUD RATE | 38400 | 2400/4800/9600/19200 /38400/57600/115200 | Select a baud rate for communication. |
| LED TALLY | ON | OFF/ON | Set whether to switch on tally light. |
| OSD TALLY MODE | RG | <ul style="list-style-type: none"> • RG: Red/Green • GR: Green only • RGY: Red/Green/Yellow • OFF: No tally light | Select the OSD Tally mode. Only the TALLY SOURCE is STANDARD, the setting is available. |
| IMD TALLY MODE | T1 | T1/T2/T1T2/T2T1/T1-/T2-/T1T2-/T2T1- | Select the IMD Tally mode. Use this setting when using the Image Video tally control, this item will determine the IMD state as the selected value. |
| TALLY | STANDARD | STANDARD/IMAGE | Select the source for |

| Items | Default Value | Domain Range | Description |
|--------|---------------|--------------|------------------|
| SOURCE | | IDEO/TSL | OSD Tally source |

1. OSD TALLY MODE

When setting IMD Menu→TALLY SOURCE item is set to be Standard, and IMD PROTOCOL is set to be Local, the TALLY lights are triggered by the GPI interface. Set GPI1 as TALLY GREEN and GPI2 as TALLY RED in GPI menu, the status of OSD TALLY and LED TALLY when the Tally connector gets the high/low level are listed as shown in **Table 5.1-16**:

Table 5.1-16 The status of OSD TALLY and LED TALLY When Triggering the Tally Pins

| OSD TALLY MODE | Green TALLY | Red TALLY | Illustration | LED TALLY |
|----------------|-------------|-----------|--------------|-----------|
| OFF | 0/1 | 0/1 | | |
| RGY | 0 | 0 | | |
| | 0 | 1 | | |
| | 1 | 0 | | |
| | 1 | 1 | | |
| GR | 0 | 0 | | |
| | 0 | 1 | | |
| | 1 | 0 | | |
| | 1 | 1 | | |
| RG | 0 | 0 | | |
| | 0 | 1 | | |
| | 1 | 0 | | |
| | 1 | 1 | | |

Tips

- If IMD DISPLAY item is ON, the IMD CHARACTER in the black bar will display on the bottom of the screen.
- The length of IMD NAME and IMD CHARACTER is up to 16 characters. The character range is from 0x00 to 0x7F of ASCII. Press **ENTER** to edit the IMD characters, than use **UP** or **DOWN** to select characters, than press **ENTER** to go to next character, press **MENU** to exit editor.
- When the IMD PROTOCOL is set to be **Local**, the IMD CHARACTER can only be modified through the control buttons(**^ (Up)** and **v (Down)**), and the IMD CHARACTER could be composed of up to 16 characters. When the IMD PROTOCOL is set to be NETWORK, the IMD CHARACTER should be modified through the IMD page in the network control page, and the IMD CHARACTER could be composed of up to 16 characters or up to 12 Chinese characters. For other values of IMD PROTOCOL, the IMD CHARACTER abides by the corresponding protocol.

The BCM-156 monitor could receive the Tally control signal from a TSL server, and display the Tally information on BCM-156 through the LED tally and OSD tally. We support the TSI3000 and TSL TallyMan Controller as the TSL server, and it will be introduce how to connect with them, and how to set the IMD parameters for various IMD protocol.

5.1.11.1 Device Connection

Follow the instructions below to connect monitor with TSL server.

1. TSI-3000--BCM-156

Connect the TSI-3000 with BCM-156, as shown in **Figure 5.1-35**:

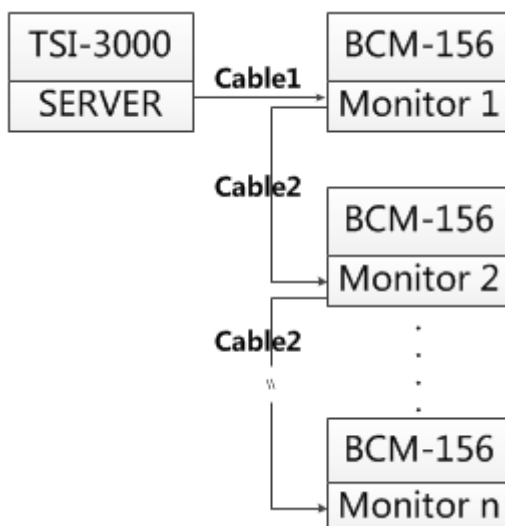

Figure 5.1-35 TSL Server and Display Monitor

We recommend the following two methods according to the different interface of TSI-3000 which is selected to connect with BCM-156.

METHOD1

Use the COM7~COM12 interface of TSI-3000 to connect with BCM-156

■ **Cable1**

Use Cable1 to connect one of the COM7~COM12 interface at the rear panel of TSI-3000 with the RS485 Interface of BCM-156, the functionality of the interfaces are as shown in the following table.

□ **RS485(BCM-156): RJ45**

Use the RS485 interface to connect with TSI-3000, the RS485 uses the RJ45 connector, and the function of RS485 interface of BCM-156 is defined as in **Table 5.1-17**:

Table 5.1-17 The Pins Input/output connectors for RS485 of BCM-156

| PIN No. | RS485 IN Terminal Signal | RS485 OUT Terminal Signal | Illustration |
|---------|--------------------------|---------------------------|--------------|
| 1,2 | GND | GND | |
| 3 | Tx- | Tx- | |
| 4 | Rx+ | Rx+ | |
| 5 | Rx- | Rx- | |
| 6 | Tx+ | Tx+ | |
| 7,8 | | | |

| PIN No. | RS485 IN Terminal Signal | RS485 OUT Terminal Signal | Illustration |
|---------|--------------------------|---------------------------|--------------|
| 7,8 | NC | NC | |

□ **COM(TSI-3000): DB9**

Use one of the **COM7~COM12** interface at the rear panel of TSI-3000 to connect with BCM-156 monitor, the **COM7~COM12** has the female DB9 connector, and the function of **COM7~COM12** interface of TSI-3000 is defined as in **Table 5.1-18**:

Table 5.1-18 The Pins of COM* in TSI-3000

| PIN No. | DB9 | Illustration |
|---------|--------------------------------|--|
| 1 | GND | <p style="text-align: center;">Female DE-9</p> |
| 2 | Rx-(data from external device) | |
| 3 | Tx+(data to external device) | |
| 4 | GND(Tx Data Common) | |
| 5 | NC | |
| 6 | GND(Rx Data Common) | |
| 7 | Rx+(data from external device) | |
| 8 | Tx-(data to external device) | |
| 9 | GND | |

The connection should obey the rules below to set up the communication between one of **COM7~COM12** and RS485, as shown in **Table 5.1-19**:

Table 5.1-19 Connection Between COM7~COM12 of TSI-3000 and RS485 of BCM-156

| DB9(COM7~COM12) | RJ45(RS485) |
|-----------------|-------------|
| 2 | 3 |
| 3 | 4 |
| 4 | 2 |
| 6 | 1 |
| 7 | 6 |

| DB9(COM7~COM12) | RJ45(RS485) |
|-----------------|-------------|
| 8 | 5 |

□ **Cable1**

The connectors at the two ends of **CABLE1** should be one male RJ45 connector and one Male DB9 connector, as shown in **Figure 5.1-36**:

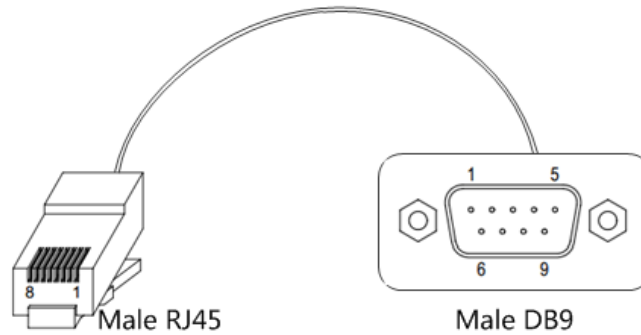

Figure 5.1-36 Cable1

The pin sequence should be defined as in **Figure 5.1-37**:

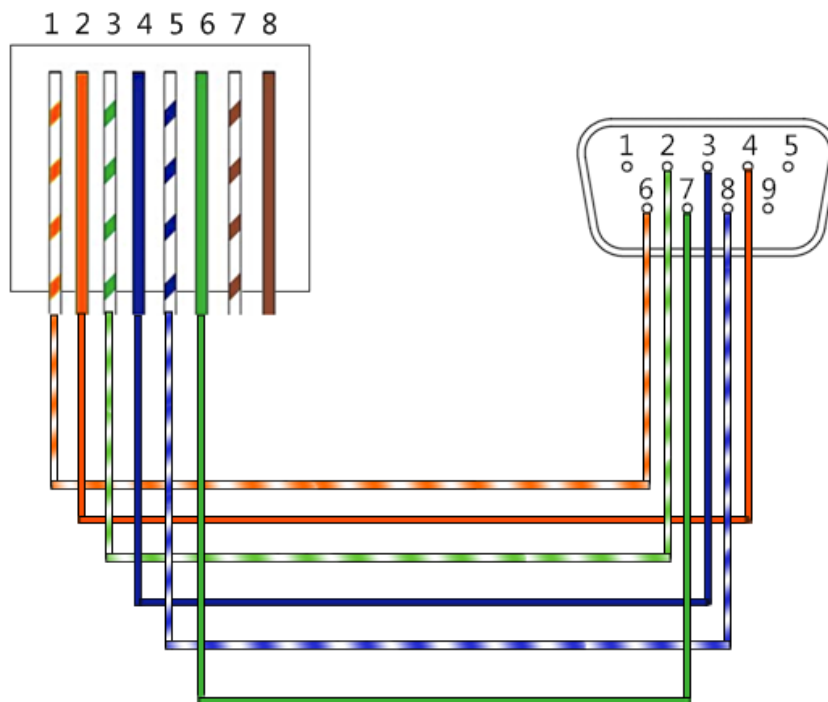

Figure 5.1-37 Pin Sequence of Cable1

METHOD2

Use the COM3~COM6 interface of TSI-3000 to connect with

BCM-156

■ Cable1

Use Cable1 to connect one of the COM3~COM6 interface at the rear panel of TSI-3000 with the RS485 Interface of BCM-156, the functionality of the interfaces are as shown in the following table.

□ RS485(BCM-156): RJ45

Use the RS485 interface to connect with TSI-3000, the RS485 uses the RJ45 connector, and the function of RS485 interface of BCM-156 is defined as in **Table 5.1-17**, please refer to the above **Table 5.1-17** for the details, no repeat here.

□ COM(TSI-3000): 6P6C

Use one of the **COM3~COM6** interface at the rear panel of TSI-3000 to connect with BCM-156 monitor, the **COM3~COM6** has the 6P6C connector, and the function of **COM3~COM6** interface of TSI-3000 is defined as in **Table 5.1-20**:

Table 5.1-20 The Pins of COM* in TSI-3000

| PIN No. | 6P6C | Illustration |
|---------|--------------------------------|--------------|
| 1 | Rx-(data from external device) | |
| 2 | GND(Data Common) | |
| 3 | Tx+(data to external device) | |
| 4 | Tx-(data to external device) | |
| 5 | Not connected | |
| 6 | Rx+(data from external device) | |

The connection should obey the rules below to set up the communication between one of **COM3~COM6** and RS485, as shown in **Table 5.1-21**:

Table 5.1-21 Connection Between COM3~COM6 of TSI-3000 and RS485 of BCM-156

| 6P6C(COM3~COM6) | RJ45(RS485) |
|-------------------|------------------|
| 1 | 3 |
| 3 | 4 |
| 2 | 2 |
| 5 (Not connected) | 1(Not connected) |

| 6P6C(COM3~COM6) | RJ45(RS485) |
|-----------------|-------------|
| 6 | 6 |
| 4 | 5 |

□ **Cable1**

The connectors at the two ends of **CABLE1** should be one male RJ45 connector and one Male 6P6C connector, as shown in **Figure 5.1-38**:

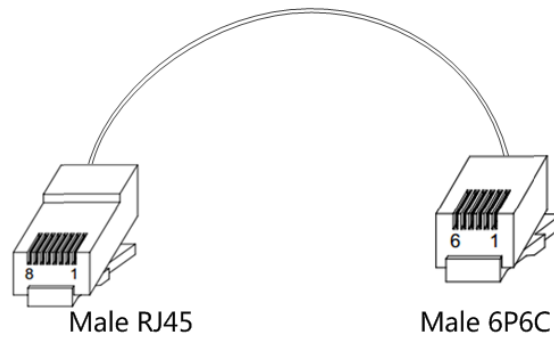

Figure 5.1-38 Cable1

The pin sequence should be defined as in **Figure 5.1-39**:

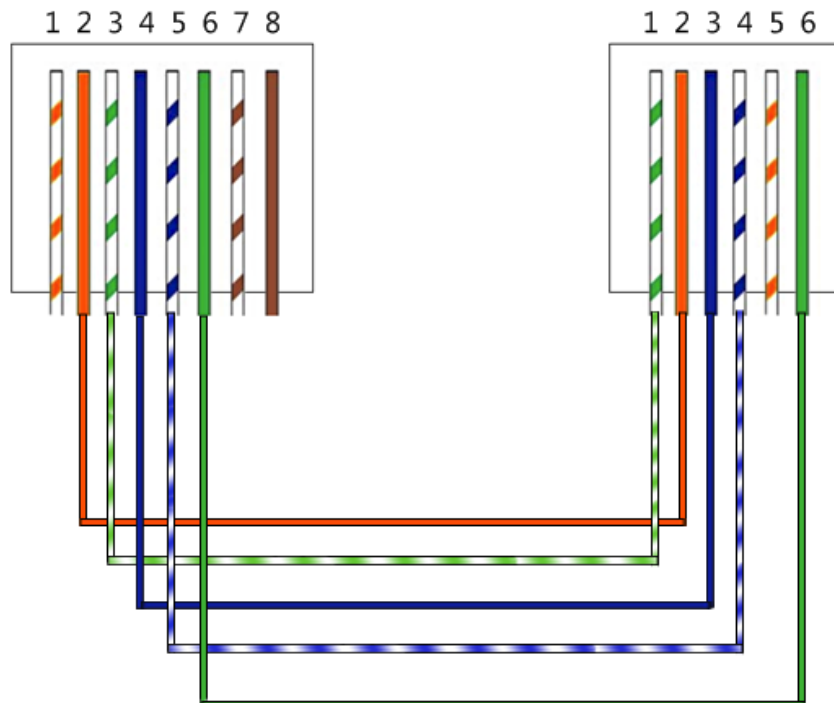

Figure 5.1-39 Pin Sequence of Cable1

2. TallyMan--BCM-156

Connect the TallyMan Controller TM1/TM2/TM2 PLUS with BCM-156, as shown in **Figure 5.1-40**:

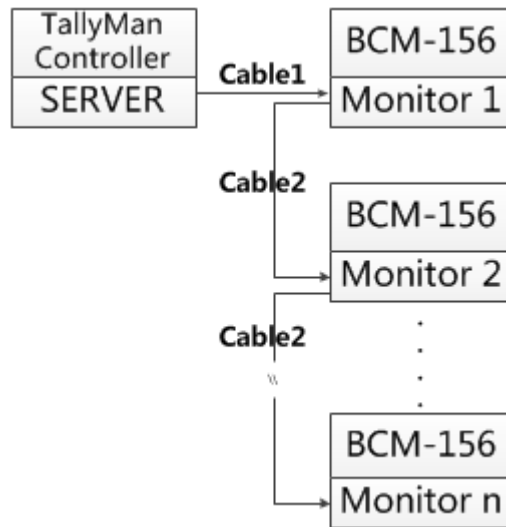

Figure 5.1-40 TSL Server and Display Monitor

■ **Cable1**

Use Cable1 to connect one of the CONTROL1/CONTROL2(RS422) interface at the rear panel of TallyMan Controller with the RS485 Interface of BCM-156, the functionality of the interfaces are as shown in the following table.

□ **RS485(BCM-156): RJ45**

The definition of RS485 interface of BCM-156 is as the same as in TSI-3000-BCM-156 system, please refer to the above **Table 5.1-17** for the details, no repeat here.

□ **RS422(TallyMan Controller): DB9**

Use one of the **CONTROL1/CONTROL2** interface at the rear panel of TallyMan Controller to connect with BCM-156 monitor, the **CONTROL1/CONTROL2** is a **RS422** interface using female DB9 connector, and the pins of DB9 is defined as in **Table 5.1-22**:

Table 5.1-22 The Pins of CONTROL1/CONTROL2 in TallyMan Controller

| PIN No. | DB9 | Illustration |
|---------|------------|--------------|
| 1 | 0v/Chassis | |
| 2 | Tx- | |
| 3 | Rx+ | |

| PIN No. | DB9 | Illustration |
|---------|-----|--|
| 4 | 0v | <p style="text-align: center;">Female DE-9</p> |
| 5 | - | |
| 6 | 0v | |
| 7 | Tx+ | |
| 8 | Rx- | |
| 9 | 0v | |

The connection should obey the rules below to set up the communication between one of **CONTROL1/CONTROL2** and RS485, as shown in **Table 5.1-23**:

Table 5.1-23 Connection Between CONTROL1/CONTROL2 of TallyMan Controller and RS485 of BCM-156

| DB9(CONTROL1/CONTROL2) | RJ45(RS485) |
|------------------------|-------------|
| 2 | 5 |
| 3 | 6 |
| 4 | 2 |
| 6 | 1 |
| 7 | 4 |
| 8 | 3 |

Tips

- TSL TallyMan Controller TM1, TSL TallyMan Controller TM2, TSL TallyMan Controller TM2 PLUS all conform to the above definition about the connection and the pins relationship. Refer to the user manuals of these devices for details.

Cable1

The connectors at the two ends of **CABLE1** should be one male RJ45 connector and one Male DB9 connector, as shown in **Figure 5.1-41**:

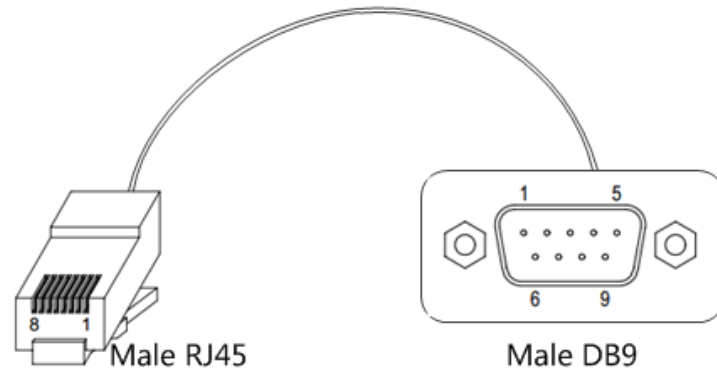

Figure 5.1-41 Cable1

The pin sequence should be defined as in **Figure 5.1-42**:

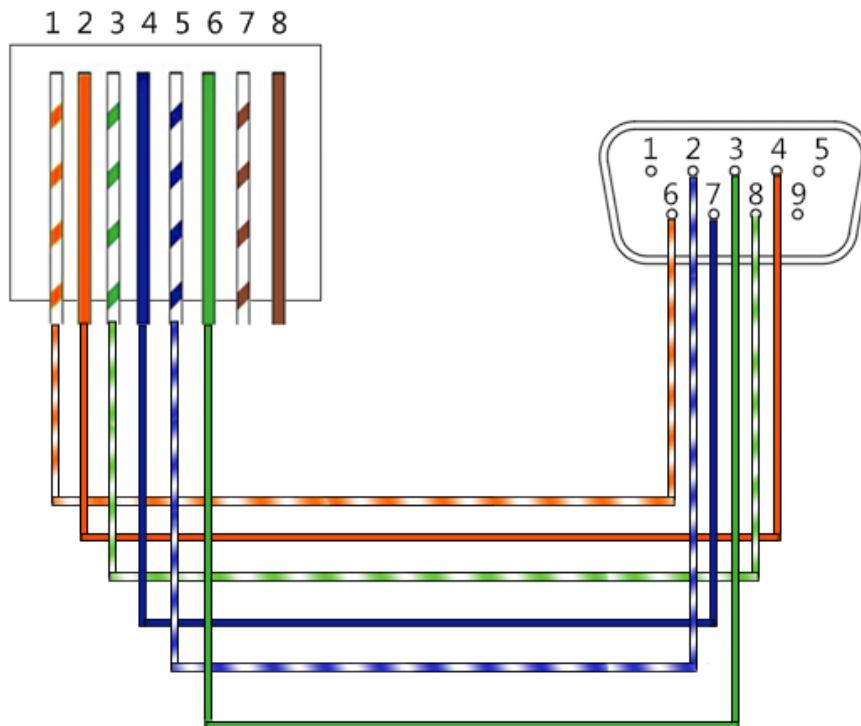

Figure 5.1-42 Pin Sequence of Cable1

■ **Cable2**

Use **Cable2** to connect every two BCM-156 monitors through the RS485 Interface, the **Cable2** is a straight through line, and the connectors at the two ends of **Cable2** should both be male RJ45. The pin sequence of **Cable2** should be defined as in **Figure 5.1-43**:

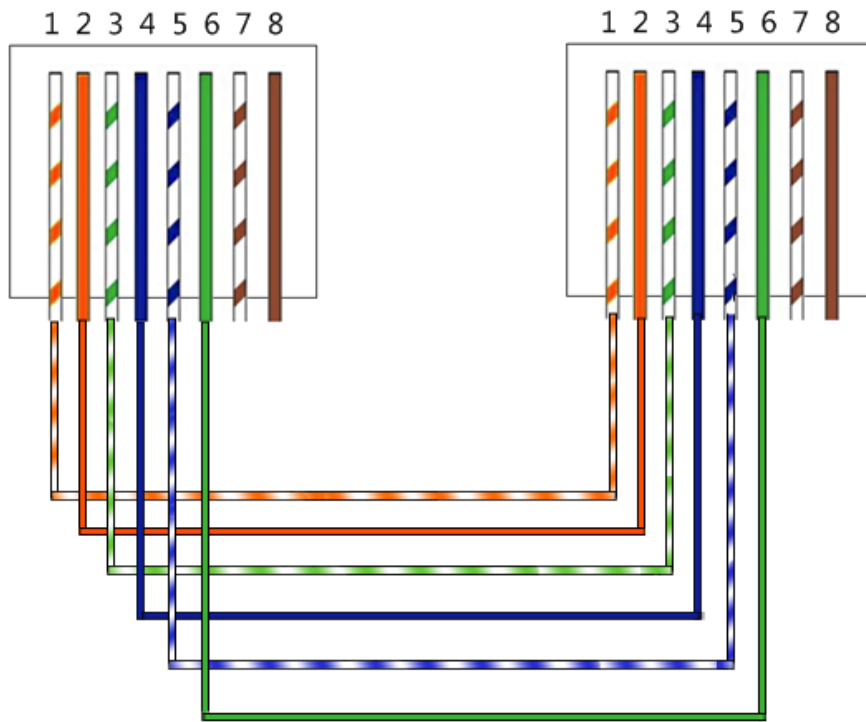

Figure 5.1-43 Pin Sequence of Cable2

5.1.11.2 IMD Settings

The position of Tally display on the BCM-156 monitor is as shown in **Figure 5.1-44**. The **LED Tally** indicator is displayed at the top center of the monitor, and the two **OSD Tally** lights are displayed at the bottom of the monitor screen, separately at the left and right side of the **IMD** characters.

The tally lights will be in various color when selecting different values for the **IMD Protocol** item. It will introduce one by one in the below.

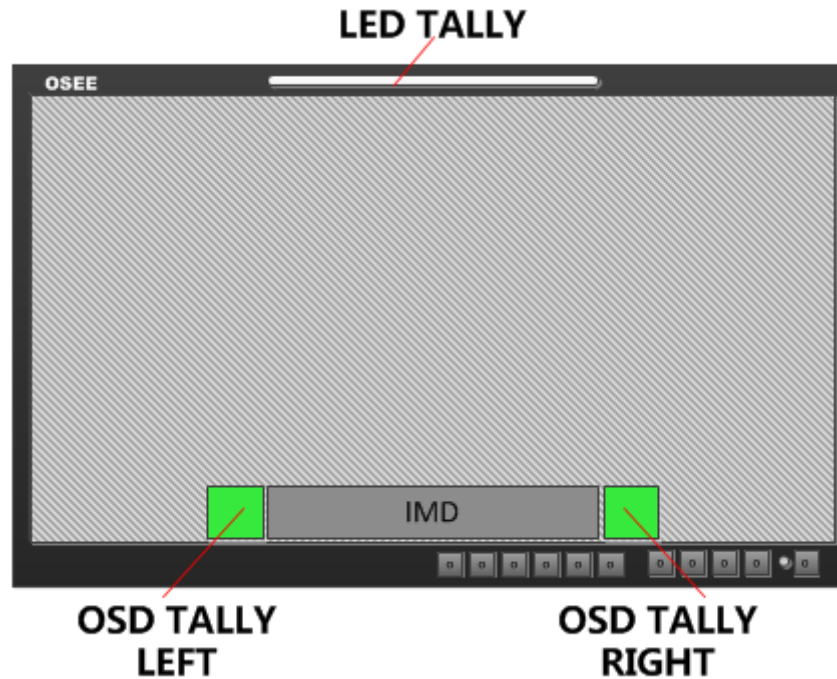

Figure 5.1-44 Tally Display

Tips

- When receiving data of TSL3.1 or TSL4.0 protocol, we support the data length to be 0~126 and 128~254. When the data is in 128~254, the result will be equal to subtract 128 from the IMD ID, in addition, the data length is 0~255 when receiving data of MAGE VIDEO protocol.

1. TSL3.1

Set **IMD→IMD Protocol** item to be TSL3.1, the monitor could receive the tally control command from a TSL Tally controller or other control devices conforming to TSL3.1 protocol.

■ Physical characteristic

| | |
|------------|-------------------|
| Com Port: | RS232/RS422/RS485 |
| DataBits: | 8 |
| StopBits: | 1 |
| Parity: | Even |
| Baud Rate: | 38400 |

■ IMD Items

| Items | Value | Description |
|----------------|--------|--|
| IMD DISPLAY | ON | |
| IMD PROTOCOL | TSL3.1 | it could receive the data of TSL4.0 protocol |
| IMD ID | 0 | |
| BAUD RATE | 38400 | |
| LED TALLY | ON | It will display as the result of OR relationship of LEFT OSD Tally and RIGHT OSD Tally. When only one of the two lights is lit, the LED Tally will light in the same color as the lit OSD Tally's, otherwise, when the two lights of OSD Tally are lit, the LED Tally will light in yellow. (This rule is not fit for LED Tally when the OSD TALLY MODE item is set to be GR.) |
| OSD TALLY MODE | RG | |
| | GR | |
| | RGY | |
| | OFF | Close the OSD TALLY |
| TALLY SOURCE | TSL | |

2. TSL4.0

Set **IMD→IMD Protocol** item to be TSL4.0, the monitor could receive the tally control command from a TSL Tally controller or other control devices conforming to TSL4.0 protocol.

■ Physical characteristic

| | |
|------------|-------------------|
| Com Port: | RS232/RS422/RS485 |
| DataBits: | 8 |
| StopBits: | 1 |
| Parity: | Even |
| Baud Rate: | 38400 |

■ IMD Items

| Items | Value | Description |
|----------------|-----------|--|
| IMD DISPLAY | ON | |
| IMD PROTOCOL | TSL4.0 | |
| IMD ID | 0 | |
| BAUD RATE | 38400 | |
| LED TALLY | ON | It will display as the result of OR relationship of LEFT OSD Tally and RIGHT OSD Tally. When only one of the two lights is lit, the LED Tally will light in the same color as the lit OSD Tally's, otherwise, when the two lights of OSD Tally are lit, the LED Tally will light in yellow. (This rule is not fit for LED Tally when the OSD TALLY MODE item is set to be GR.) |
| OSD TALLY MODE | RG/GR/RGY | Select anyone of these three items to open the OSD TALLY, the color and the status of the LEFT OSD TALLY and RIGHT OSD TALLY will conform to the receiving instructions of the corresponding TSL protocol. |
| | OFF | Close the OSD TALLY |
| TALLY SOURCE | TSL | |

3. Image Video

Set **IMD→IMD Protocol** item to be IMAGE VIDEO, the monitor could receive the tally control command from an IMAGE VIDEO controller or other control devices conforming to IMAGE VIDEO protocol.

- Physical characteristic

| | |
|------------|-------------|
| Com Port: | RS232/RS485 |
| DataBits: | 7 |
| StopBits: | 2 |
| Parity: | Even |
| Baud Rate: | 38400 |

- IMD Items

| Items | Value | Description |
|--------------|-------------|-------------|
| IMD DISPLAY | ON | |
| IMD PROTOCOL | IMAGE VIDEO | |
| IMD ID | 0 | |

| Items | Value | Description |
|----------------|-------------|--|
| BAUD RATE | 38400 | |
| LED TALLY | ON | It will display as the result of OR relationship of LEFT OSD Tally and RIGHT OSD Tally. When only one of the two lights is lit, the LED Tally will light in the same color as the lit OSD Tally's, otherwise, when the two lights of OSD Tally are lit, the LED Tally will light in yellow. (This rule is not fit for LED Tally when the OSD TALLY MODE item is set to be GR.) |
| OSD TALLY MODE | RG/GR/RGY | Select anyone of these three items to open the OSD TALLY, the color and the status of the LEFT OSD TALLY and RIGHT OSD TALLY will comfort to the receiving instructions of the IMAGE VIDEO protocol. |
| | OFF | Close the OSD TALLY |
| IMD TALLY MODE | T1 | T1/T2/T1T2/T2T1/T1-/T2-/T1T2-/T2T1-(Comfort to the receiving instructions of the IMAGE VIDEO protocol, refer to IMAGE VIDEO protocol for details) |
| TALLY SOURCE | IMAGE VIDEO | |

The monitor supports the following command set in IMAGE VIDEO 1510 protocol: D(d), S(s), C(c), J(j), O(o), U(u), Z(z). And the following command set are not supported currently: F(f), T(t), A(a), 1Y(y), I(i), 1L(l), V(v), Q(q), N(n),X(x).

We has only one IMD information on the screen, so in S(s) command, the line number for the UMD text can just be 1, for example, the command should be:

%0D%1Sone line%z.

4. TSL5.0

Set **IMD→IMD Protocol** item to be TSL5.0, the monitor could receive the tally control command from network devices conforming to UDP protocol.

- Physical characteristic

Use RJ45 interface in UDP protocol, the maximum length of data package is 2048 Bytes, and the port number is 5000.

5.1.12 KEY INHIBIT Menu

The KEY INHIBIT menu item is used to lock the setting so that they can't be changed by an unauthorized user, and the menu item is as shown in Figure 5.1-45:

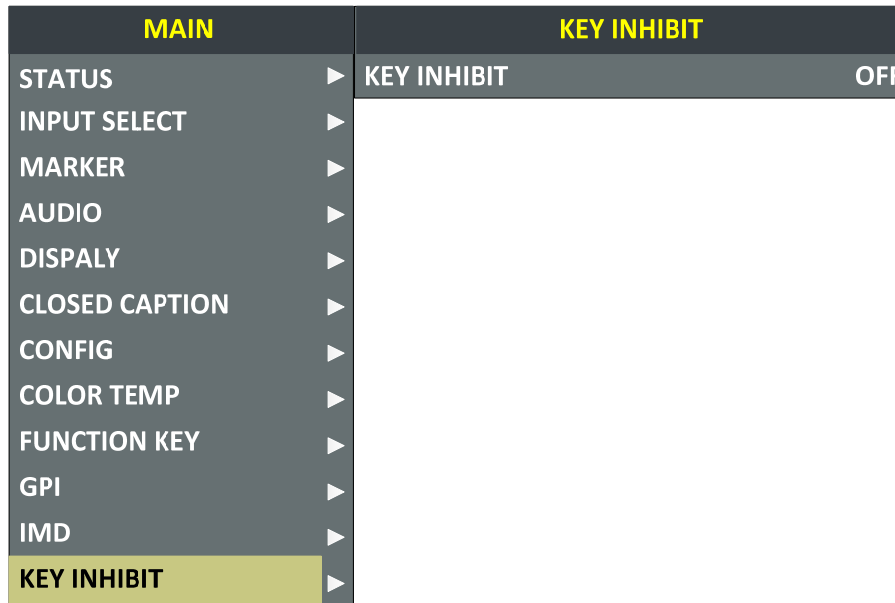

Figure 5.1-45 KEY INHIBIT Menu

The relationship of Items, Default Value, Domain Range and Description of the sub-item is shown in Table 5.1-24:

Table 5.1-24 The Description of KEY INHIBIT Menu Items

| Items | Default Value | Domain Range | Description |
|-------------|---------------|--------------|-------------------------|
| KEY INHIBIT | OFF | OFF/ON | Enable/Disable the key. |

i Tips

- When the KEY INHIBIT is ON, KEY INHIBIT is enabled and press the POWER key, the device would turn on or off. MENU, UP, DOWN, ENTER key can be enable but only to set the KEY INHIBIT item, or there is a “KEY INHIBIT” prompt displayed on the screen when using other keys.

5.2 Menu Settings

When checking or modifying the value of the menu item, cooperating with the following buttons: MENU, UP, DOWN, ENTER.

1. Operations to the Main menu

- Display the Main Menu

Press **MENU** button to enter into the main menu, it displays at the top left corner of the screen.

■ **Switch menu items**

After displaying the main menu, press **UP** or **DOWN** button to choose a menu item, the menu item selected is in yellow. For example, you have selected **Status** menu, as shown in Figure 5.2-1.

| MAIN | STATUS |
|----------------|--------------------------------|
| STATUS | INPUT SDI1 |
| INPUT SELECT | FORMAT NO SIGNAL |
| MARKER | COLOR TEMP D65 |
| AUDIO | SCAN MODE OVER |
| DISPALY | FAST MODE OFF |
| CLOSED CAPTION | MODEL BCM-156-3HSV |
| CONFIG | SERIAL NUMBER BCM1562015010001 |
| COLOR TEMP | IP ADDRESS 192.168.1.86 |
| FUNCTION KEY | COLOR VERSION 2015 -1 -5.4 |
| GPI | |
| IMD | |
| KEY INHIBIT | |

Figure 5.2-1 Selecting STATUS Menu

■ **Back to the Main menu**

After entering to a sub-menu item or a sub-menu item value, press **MENU** button to back to the upper level menu area.

■ **Close the Main menu**

Press **MENU** button to close the Main menu when the control icon is in the Main menu item.

i Tips

- After you have loaded the Main menu, it will be closed automatically if you do nothing operation with it in 60s.

2. Operations to sub-menu item

■ **Display the sub-menu item**

After display the Main menu, press **UP** or **DOWN** button to select a menu item, and the right part displays its sub-menu items according to the current selected menu item.

■ **Switch sub-menu items**

After displaying the sub-menu items list, press **ENTER** button to enter into the sub-menu items list, press **UP** or **DOWN** button to choose a sub-menu item, a yellow rectangle is in front of the selected sub-menu item.

■ **Back to menu item**

After entering to the sub-menu item value, press **MENU** button to back to menu items, or after setting the sub-menu item value and press **Enter** button to firm the modification, the control icon is back to the corresponding sub-menu item, as shown in Figure 5.2-2:

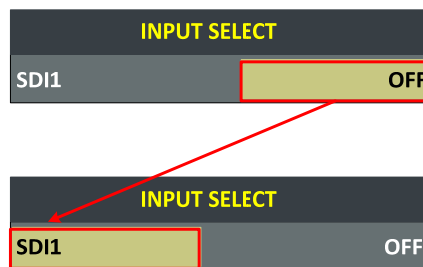

Figure 5.2-2 The Control Icon Moves from the Sub-menu Item Value to the Corresponding Sub-menu Item

3. Operations to sub-menu item value

■ **Switch sub-menu item value**

When the control icon is in sub-menu item value, press **UP** or **DOWN** button to switch among its value list.

■ **Confirm the modification to sub-menu item value**

Press **ENTER** button to confirm the selection of a value, and the control icon is back to the corresponding sub-menu item.

■ **Abandon the modification to sub-menu item value**

Press **MENU** button to give up the modification to sub-menu item value, and the control icon is back to the corresponding sub-menu item.

Tips

- The value in white color is modifiable, and the value in blue color is unmodifiable.

4. Selecting the Menu Language

You can select one of languages (English or Chinese) for displaying the menu. The default language for the menu is ENGLISH. The following

will teach you how to switch to Chinese.

■ Operation:

Step 1 Select CONFIG menu

Press **MENU** button to display the OSD menu, click **DOWN** button to select **CONFIG** menu.

Step 2 Select the value of the Language item

Press **ENTER** button to get into the **CONFIG** menu items, and click **DOWN** button to select the sub-item **LANGUAGE**, then, click **ENTER** button to get into the sub-value list, as shown in Figure 5.2-3, the current control icon is in **ENGLISH**.

| MAIN | | CONFIG | |
|----------------|---|------------------|----------------|
| STATUS | ▶ | FAST MODE | OFF |
| INPUT SELECT | ▶ | FILM MODE DETECT | OFF |
| MARKER | ▶ | SUB IN TYPE | PBP |
| AUDIO | ▶ | SUB IN SELECT | SDI1 |
| DISPALY | ▶ | PIP SIZE | LARGE |
| CLOSED CAPTION | ▶ | PIP POSITION | HORIZONTAL |
| CONFIG | ▶ | BACKLIGHT | 15 |
| COLOR TEMP | ▶ | AUTO STANDBY | OFF |
| FUNCTION KEY | ▶ | APPEATURE | 0 |
| GPI | ▶ | LOCK NUMBER | XXXXXXXX |
| IMD | ▶ | LANGUAGE | ENGLISH |
| KEY INHIBIT | ▶ | H FLIP | OFF |

Figure 5.2-3 Select the Value of Language

Step 3 Confirm the modification of the value of sub-item

Click **DOWN** button to select the sub-item **LANGUAGE** to **Chinese**, as shown in Figure 5.2-4, press **ENTER** button to confirm the modification.

| 主菜单 | 系统配置 |
|-------|--------------|
| 状态显示 | 快速模式 关闭 |
| 输入设置 | 电影模式检测 关闭 |
| 标记设置 | 子画面类型 PBP |
| 音频设置 | 子画面输入源 SDI1 |
| 显示设置 | PIP大小 小 |
| 隐藏字幕 | PIP位置 右下 |
| 系统配置 | 背光 15 |
| 色彩配置 | 自动关机 关闭 |
| 功能键设置 | 清晰度 0 |
| GPI设置 | 授权码 XXXXXXXX |
| IMD设置 | 语言 中文 |
| 按键锁定 | 水平翻转 关闭 |

Figure 5.2-4 Switching the Value of LANGUAGE

Step 4 Exit the main menu

Click MENU button to exit the main menu.

Chapter 6 Network Control

BCM-156 supports network interface. Connect a computer with BCM-156 through this interface to achieve the network control to BCM-156.

Tips

- The network address of the computer which is connected with BCM-156 and the network address of BCM-156 must be in the same segment.

This chapter will introduce how to set and check the parameters of BCM-156 in Internet Explorer.

6.1 Access the settings

Use Internet Explorer to enter into a web control page. For example, input <http://192.168.1.86> in address bar, it will display the then, press Enter key, the management interface of BCM-156 is shown as in Figure 6.1-1:

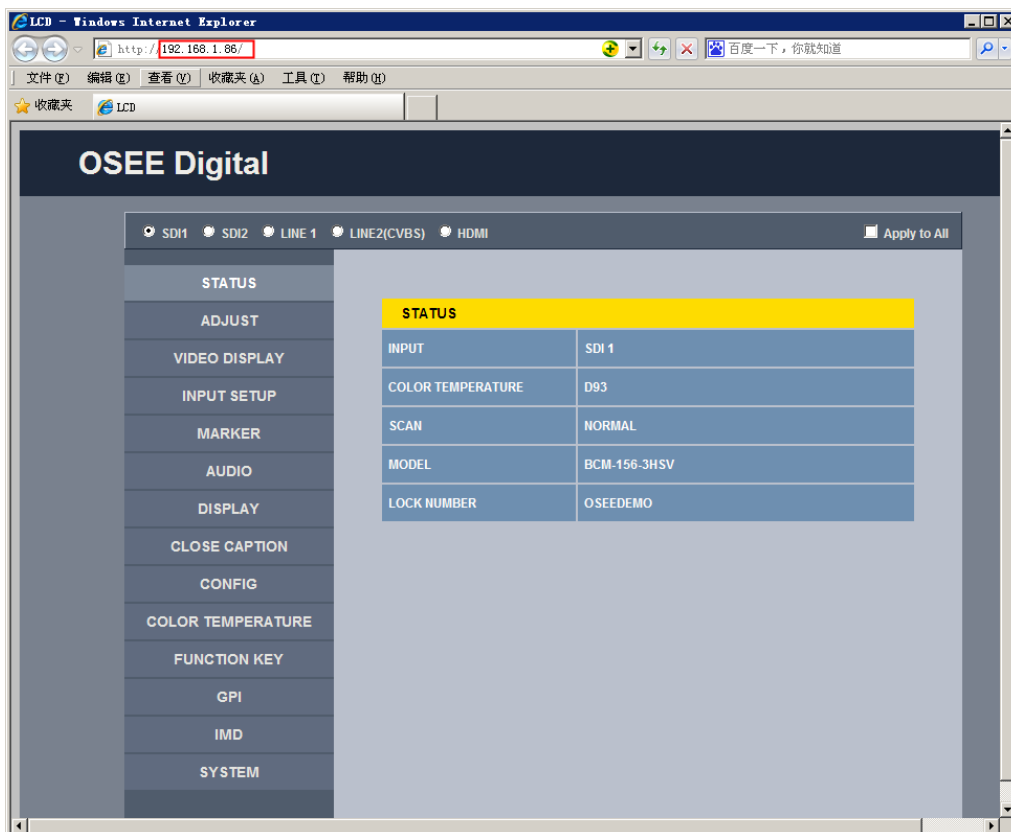

Figure 6.1-1 Network Control Page

6.2 Menu Control

Open the management interface as shown in Figure 6.2-1, the menu items listed in the left part are almost as the same as the main menu items.

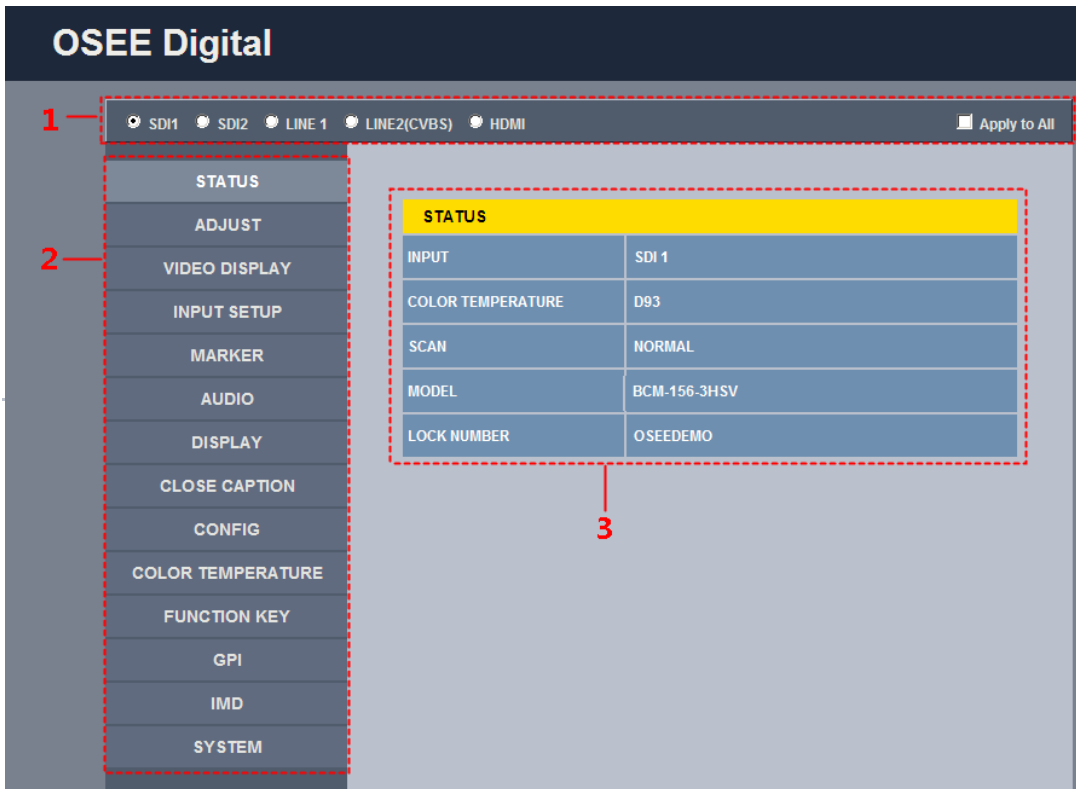

Figure 6.2-1 Management Interface

As shown in Figure 6.2-1, the management interface is divided into the following parts:

1. Input Source Selection Button

It is used to selecting an input source as the input signal, such as: SDI1, SDI2, LINE1, LINE2(CVBS), HDMI. The selecting box of "Apply to All" at the right side is used to synchronize the settings for all the other kinds of input sources.

2. Navigation menu list

It shows the navigation menus: **STATUS**, **ADJUST**, **VIDEO DISPLAY**, **INPUT SETUP**, **MARKER**, **AUDIO**, **DISPLAY**, **CLOSE CAPTION**, **CONFIG**, **COLOR TEMPERATURE**, **FUNCTION KEY**, **GPI**, **IMD** and **SYSTEM**. Click the navigation menu, it will show the corresponding settings on the right side. The menu items in main menu on screen display are mostly as the same as the menu items listed in navigation menus except **SYSTEM**, **ADJUST** and **VIDEO DISPLAY**.

3. Parameter list

It shows the parameter names, values and operation buttons of the selected navigation menu, as shown in the red rectangle in Figure 6.2-2. The title in the yellow rectangle of the parameter list and the parameter list will change with the navigation menu when switched.



Figure 6.2-2 Parameter List

Tips

- There may be a “(S)” icon followed by some parameter name in the parameter list, it is mean that this parameter is only a local parameter for the current selected signal source, otherwise, the parameter is global and the modification is valid for all signal sources.
- The **SET** button is used to confirm the modification of the parameter value.

6.2.1 ADJUST Menu

It will introduce **ADJUST** menu.

Click **ADJUST** button at the left navigation menu list, it will display the adjust parameters, as shown in Figure 6.2-3:

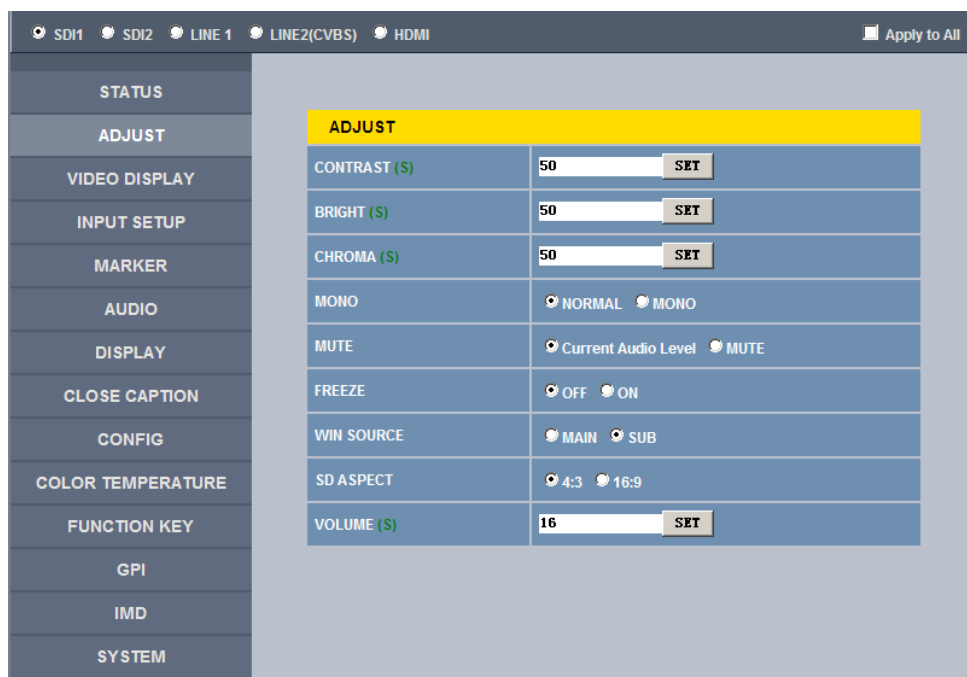

Figure 6.2-3 ADJUST Menu

The relationship of Items, Default Value, Domain Range and Description of the sub-item is shown in Table 6.2-1:

Table 6.2-1 The Description of ADJUST Menu Items

| Items | Default Value | Domain Range | Description |
|------------|---------------------|---------------------------|--|
| CONTRAST | 50 | 0~100 | Adjust the picture contrast |
| BRIGHTNESS | 50 | 0~100 | Adjust the picture brightness |
| CHROMA | 50 | 0~100 | Adjust the picture monochroma |
| MONO | NORMAL | NORMAL/MONO | Enable/disable Monochrome mode, normal mode is actually the color mode |
| MUTE | Current Audio Level | Current Audio Level /MUTE | Enable/disable the audio monitor |
| FREEZE | OFF | OFF/ON | Enable/disable the current picture to be stopped or played. |
| WIN SOURCE | MAIN | MAIN/SUB | Set the picture displaying mode in full mode or in sub-picture |

| Items | Default Value | Domain Range | Description |
|-----------|---------------|--------------|----------------------|
| | | | mode |
| SD ASPECT | 4:3 | 4:3/16:9 | Set the aspect ratio |
| VOLUME | 15 | 0~31 | Adjust the volume |

6.2.2 VIDEO DISPLAY Menu

It will introduce **VIDEO DISPLAY** menu.

Click **VIDEO DISPLAY** button at the left navigation menu list, it will display the video display parameters, as shown in Figure 6.2-4:

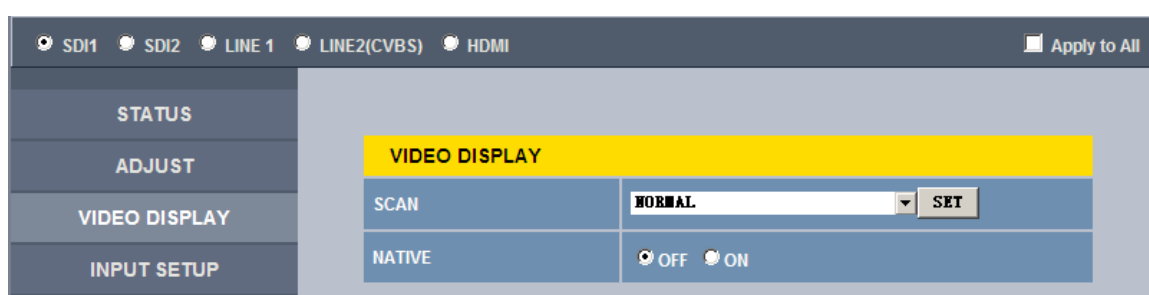

Figure 6.2-4 VIDEO DISPLAY Menu

The relationship of Items, Default Value, Domain Range and Description of the sub-item is shown in Table 6.2-2:

Table 6.2-2 The Description of VIDEO DISPLAY Menu Items

| Items | Default Value | Domain Range | Description |
|--------|---------------|---|---|
| SCAN | NORMAL | <ul style="list-style-type: none"> NORMAL OVERSCAN UNDERSCAN | Set the scan mode |
| NATIVE | OFF | OFF/ON | Whether to display the picture dot by dot |

6.2.3 SYSTEM Menu

It will introduce **SYSTEM** menu.

Click **SYSTEM** button at the left navigation menu list, it will display the system parameters, as shown in Figure 6.2-5:



Figure 6.2-5 System Menu

The relationship of Items, Default Value, Domain Range and Description of the sub-item is shown in Table 6.2-3:

Table 6.2-3 The Description of System Menu Items

| Items | Default Value | Domain Range | Description |
|--------------|---------------|--------------|-----------------------|
| IP | 192.168.1.86 | - | IP address |
| MASK | 255.255.255.0 | - | Subnet mask |
| Gateway | 192.168.1.1 | - | Gateway address |
| LOCK NUMBER | XXXXXX | - | Set the Serial Number |
| MPU Version | 12 | - | Product information |
| FPGA Version | 4 | - | Product information |
| NCU Version | 101 | - | Product information |

6.2.4 Other Menus

For the menu items in management interface are almost as the same as the menu items in the Main menu on screen, there will be no further description about their meanings and value range in this chapter, refer to “Chapter 5 Functionality of the Main Menu” for the details about **STATUS**, **VIDEO CONFIG**, **AUDIO CONFIG**, **MARKER**, **DISPLAY**, **USER CONFIG**,

COLOR TEMPERATURE and so on.

6.3 Parameter Settings

It will introduce how to modify parameter values in management interface in the followings.

For example: modify **Meter Select** in **AUDIO** menu. Click **AUDIO** button to display its parameter list, as shown in Figure 6.3-1, the corresponding screen main menu is shown as in Figure 6.3-2:

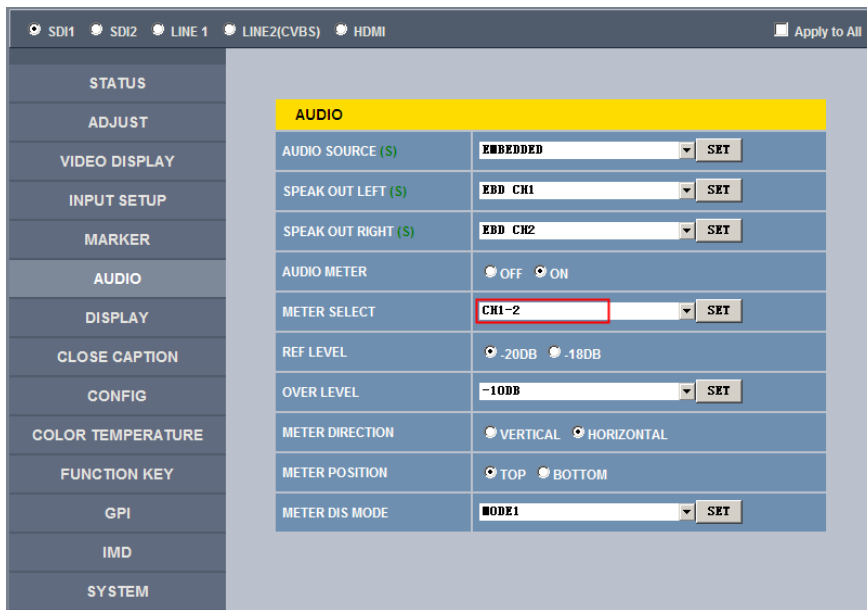

Figure 6.3-1 Parameter List for AUDIO

| MAIN | AUDIO |
|---------------|----------------------------|
| STATUS | AUDIO SOURCE AUDIO1 |
| INPUT SELECT | SPEAK OUT L EBD CH1 |
| MARKER | SPEAK OUT R EBD CH1 |
| AUDIO | AUDIO METER OFF |
| DISPALY | METER SELECT CH1-2 |
| CLOSE CAPTION | METER DIRECTION HORIZONTAL |
| CONFIG | METER POSITION TOP |
| COLOR TEMP | METER DIS MODE MODE1 |
| FUNCTION KEY | REF LEVEL -20dB |
| GPI | OVER LEVEL -10dB |
| IMD | |
| KEY INHIBIT | |

Figure 6.3-2 Screen Main Menu for AUDIO

Click button to display the drop-down value list for the parameter, as shown in Figure 6.3-3, for example, modify “CH1-2” to “G1”.

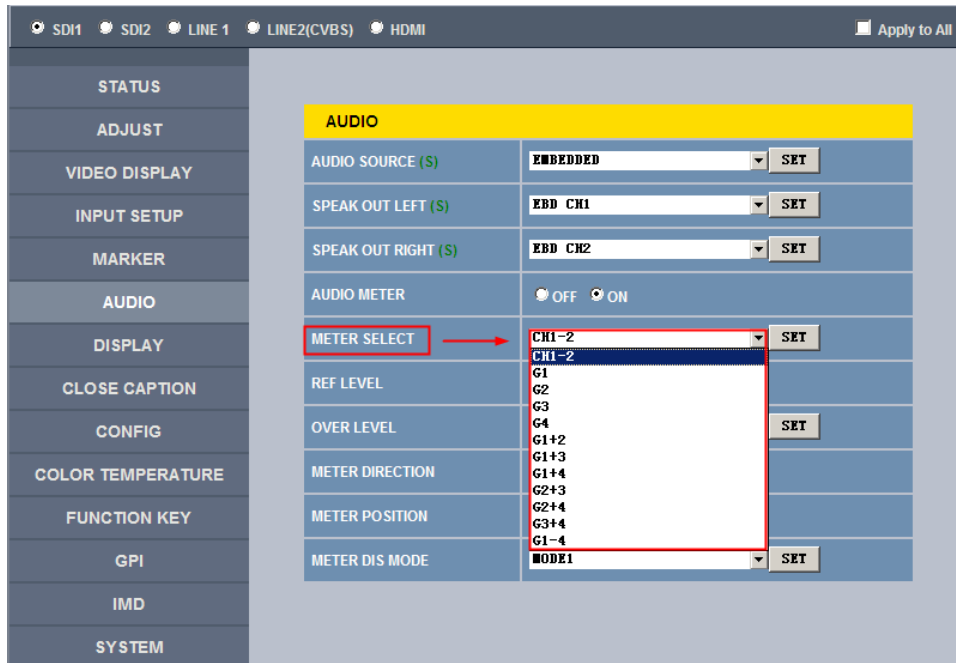

Figure 6.3-3 Display the Drop Down Value List of Meter Select(S)

Click button to confirm the selection and the page is refreshed. You can check the modification on the screen menu, the results are the same as shown in Figure 6.3-4 and Figure 6.3-5:



Figure 6.3-4 Modify the Value of a Parameter

i Tips

- The volume can be checked and modified in adjust menu on screen adjustment, or in **Volume** item of **ADJUST** menu in management interface.

| MAIN | | AUDIO | |
|---------------|---|---------------------|------------|
| STATUS | ▶ | AUDIO SOURCE | AUDIO1 |
| INPUT SELECT | ▶ | SPEAK OUT L | EBD CH1 |
| MARKER | ▶ | SPEAK OUT R | EBD CH1 |
| AUDIO | ▶ | AUDIO METER | OFF |
| DISPALY | ▶ | METER SELECT | G1 |
| CLOSE CAPTION | ▶ | METER DIRECTION | HORIZONTAL |
| CONFIG | ▶ | METER POSITION | TOP |
| COLOR TEMP | ▶ | METER DIS MODE | MODE1 |
| FUNCTION KEY | ▶ | REF LEVEL | -20dB |
| GPI | ▶ | OVER LEVEL | -10dB |
| IMD | ▶ | | |
| KEY INHIBIT | ▶ | | |

Figure 6.3-5 The Value is Modified Simultaneously on Screen Menu

Likewise, if you modify the value of a parameter on screen menu first, you may check the same changing result in management interface through network connection.

032222

Chapter 7 Specifications

1. Product detailed information

| Specification | Values | | | |
|--------------------------------|---|---------------------|------------------------------|--------------------|
| Model | BCM-156 | BCM-170 | BCM-215 | BCM-230 |
| Dimension | 15.6" | 17" | 21.5" | 23" |
| Dimension(WxHxD) | 380.7x240x70.5mm | 421.8x264.31x64.8mm | 519x321x66.3mm | 556.5x340.5x66.8mm |
| Pixel Pitch (WxH) | 0.179x0.179mm | 0.199x0.199mm | 0.2475x0.2475mm | 0.2652x0.2652mm |
| Aspect Ratio | 16:9 | | | |
| Display Area (WxH) | 344.16x193.59mm | 381.9 x 214.8mm | 475.2x267.3mm | 509.184x286.416mm |
| Viewing Angle (HxV) | 178° x178° | | | |
| Color Depth | 1.07B colors | | 16.7M colors (6-bit + A-FRC) | |
| Resolution | 1920x1080 | | 1920x1080 | |
| Contrast (Typ.) | 700:1 | 800:1 | 1000:1 | 1000:1 |
| Luminance (cd/m ²) | 210 | 300 | 250 | 250 |
| Response Time (ms) | 15 | 35 | 20 | 14 |
| Backlight | RGB LED | | White LED | |
| Backlight Life(Hrs) | 15000 | 15000 | 30000 | 30000 |
| Work Temperature | 0° C~50° C | | | |
| Power Supply | 5A12V DC | | | |
| Power Consumption | 25W | 28W | 30W | 35W |
| Video Input Interface | CVBS(X2), S-Video, YPbPr, HDMI(DVI-D), 3G/HD/SD-SDI(X2) | | | |
| Video Output Interface | CVBS(X2), S-Video, YPbPr, 3G/HD/SD-SDI(X2) | | | |
| Audio Input Interface | 2CH Analog Stereo, 5dBu, Impedance ≥47K, RCA(X4) | | | |
| Audio Output Interface | 1CH Analog Stereo, 5dBu, Impedance ≤500Ω, RCA(X2) | | | |
| Control Interface | GPI(6GPI Input RJ45)X1 | | | |
| | RS485(cascade RJ45) X2 | | | |
| | Ethernet(10/100M adaptive RJ45) X1 | | | |
| Signal Formats | CVBS: PAL, NTSC | | | |
| | SD-SDI: 480i60, 576i50 | | | |
| | HD-SDI: 1080i50, 1080i 59.94, 1080i 60, 720p50, 720p 59.94, 720p 60, 1035i59.94, 1035i 60 | | | |
| | 3G-SDI: 1080p50, 1080p60 | | | |
| CVBS Input/Output | | | | |
| Signal Type | NTSC, PAL | | | |
| Signal Amplitude | 1Vp-p+/-3dB | | | |
| Impedance | 75Ω | | | |

| Specification | Values |
|---|--|
| Return Loss | >40 dB to 5 MHz |
| DC Offset | 0V±0.05 V |
| Frequency Response | ±0.2 dB to 5 MHz |
| Differential Gain | <1% |
| Differential Phase | <1.5° |
| 3G-SDI /HD-SDI /SDI-SDI Input/Output | |
| Signal Type | SMPTE 424M, SMPTE 292M, SMPTE 259M, SMPTE 297M, SMPTE ST 2048-2 |
| Connector | BNC per IEC 169-8 |
| Impedance | 75Ω |
| Return Loss | >18 dB 5 to 270 MHz >15 dB 270 MHz to 1.5 GHz >10 dB up to 3 GHz |
| Maximum Signal Level | 800 mV pk-pk 10% |
| Signal Amplitude | 800 mV pk-pk 10% |
| DC Offset | 0 V ±0.5 V |
| Overshoot | <10% |
| Jitter | <0.2 UI |
| Rise/Fall Time | <700 ps for SD <270 ps for 1.5 Gb/s HD <135 ps for 3 Gb/s HD |
| Extinction Ratio | >8 |
| Back Reflection | <-14 dB |

*The unit about the appearance attributes in above table is mm.

2. Input/Output Resolution, Frame Refresh Rate and Color Matrix

| Input Signal | ASPECT RATIO | NORMAL SCAN | | OVER SCAN | | UNDER SCAN | | NATIVE |
|--------------|--------------|-------------|-----------|-----------|-----------|------------|-----------|----------|
| | | Input | Output | Input | Output | Input | Output | |
| PAL | 4:3 | 720X576 | 1440x1080 | 684x547 | 1440x1080 | 720X576 | 1368X1026 | 720X576 |
| | 16:9 | | 1920X1080 | | 1920X1080 | | 1824X1026 | |
| NTSC | 4:3 | 720X483 | 1440x1080 | 684x458 | 1440x1080 | 720X483 | 1368X1026 | 720X483 |
| | 16:9 | | 1920X1080 | | 1920X1080 | | 1824X1026 | |
| 480I60/59.94 | 4:3 | 720X483 | 1440x1080 | 684x458 | 1440x1080 | 720X483 | 1368X1026 | 720X483 |
| | 16:9 | | 1920X1080 | | 1920X1080 | | 1824X1026 | |
| 576I50 | 4:3 | 720X576 | 1440x1080 | 684x547 | 1440x1080 | 720X576 | 1368X1026 | 720X576 |
| | 16:9 | | 1920X1080 | | 1920X1080 | | 1824X1026 | |
| 480P60/59.94 | 4:3 | 720X483 | 1440x1080 | 684x458 | 1440x1080 | 720X483 | 1368X1026 | 720X483 |
| | 16:9 | | 1920X1080 | | 1920X1080 | | 1824X1026 | |
| 576P50 | 4:3 | 720X576 | 1440x1080 | 684x547 | 1440x1080 | 720X576 | 1368X1026 | 720X576 |
| | 16:9 | | 1920X1080 | | 1920X1080 | | 1824X1026 | |
| 720P24/23.97 | 16: 9 | 1280X720 | 1920X1080 | 1216X684 | 1920X1080 | 1280X720 | 1824X1026 | 1280X720 |

| Input Signal | ASPECT RATIO | NORMAL SCAN | | OVER SCAN | | UNDER SCAN | | NATIVE |
|-----------------------|--------------|-------------|-----------|-----------|-----------|------------|-----------|-----------|
| | | Input | Output | Input | Output | Input | Output | |
| | 2.39: 1 | | 1920X803 | | 1920X803 | | 1824X763 | |
| 720P25 | 16: 9 | 1280X720 | 1920X1080 | 1216X684 | 1920X1080 | 1280X720 | 1824X1026 | 1280X720 |
| | 2.39: 1 | | 1920X803 | | 1920X803 | | 1824X763 | |
| 720P30/29.97 | 16: 9 | 1280X720 | 1920X1080 | 1216X684 | 1920X1080 | 1280X720 | 1824X1026 | 1280X720 |
| | 2.39: 1 | | 1920X803 | | 1920X803 | | 1824X763 | |
| 720P50 | 16: 9 | 1280X720 | 1920X1080 | 1216X684 | 1920X1080 | 1280X720 | 1824X1026 | 1280X720 |
| | 2.39: 1 | | 1920X803 | | 1920X803 | | 1824X763 | |
| 720P60/59.94 | 16: 9 | 1280X720 | 1920X1080 | 1216X684 | 1920X1080 | 1280X720 | 1824X1026 | 1280X720 |
| | 2.39: 1 | | 1920X803 | | 1920X803 | | 1824X763 | |
| 1080SF24/23.97 | 16: 9 | 1920X1080 | 1920X1080 | 1824X1026 | 1920X1080 | 1920X1080 | 1824X1026 | 1920X1080 |
| | 2.39: 1 | | 1920X803 | | 1920X803 | | 1824X763 | |
| 1035I60/59.94 | 16: 9 | 1920X1080 | 1920X1080 | 1824X1026 | 1920X1080 | 1920X1080 | 1824X1026 | 1920X1035 |
| | 2.39: 1 | | 1920X803 | | 1920X803 | | 1824X763 | |
| 1080I50 | 16: 9 | 1920X1080 | 1920X1080 | 1824X1026 | 1920X1080 | 1920X1080 | 1824X1026 | 1920X1080 |
| | 2.39: 1 | | 1920X803 | | 1920X803 | | 1824X763 | |
| 1080I60/59.94 | 16: 9 | 1920X1080 | 1920X1080 | 1824X1026 | 1920X1080 | 1920X1080 | 1824X1026 | 1920X1080 |
| | 2.39: 1 | | 1920X803 | | 1920X803 | | 1824X763 | |
| 1080P24/23.97 | 16: 9 | 1920X1080 | 1920X1080 | 1824X1026 | 1920X1080 | 1920X1080 | 1824X1026 | 1920X1080 |
| | 2.39: 1 | | 1920X803 | | 1920X803 | | 1824X763 | |
| 1080P25 | 16: 9 | 1920X1080 | 1920X1080 | 1824X1026 | 1920X1080 | 1920X1080 | 1824X1026 | 1920X1080 |
| | 2.39: 1 | | 1920X803 | | 1920X803 | | 1824X763 | |
| 1080P30/29.97 | 16: 9 | 1920X1080 | 1920X1080 | 1824X1026 | 1920X1080 | 1920X1080 | 1824X1026 | 1920X1080 |
| | 2.39: 1 | | 1920X803 | | 1920X803 | | 1824X763 | |
| 1080P50 | 16: 9 | 1920X1080 | 1920X1080 | 1824X1026 | 1920X1080 | 1920X1080 | 1824X1026 | 1920X1080 |
| | 2.39: 1 | | 1920X803 | | 1920X803 | | 1824X763 | |
| 1080P60/59.94 | 16: 9 | 1920X1080 | 1920X1080 | 1824X1026 | 1920X1080 | 1920X1080 | 1824X1026 | 1920X1080 |
| | 2.39: 1 | | 1920X803 | | 1920X803 | | 1824X763 | |
| 2048X1080PS F24/23.97 | 1.896:1 | 2048X1080 | 1920X1013 | 1946X1026 | 1920X1013 | 2048X1080 | 1824X962 | 2048X1080 |
| | 2.39: 1 | | 1920X803 | | 1920X803 | | 1824X763 | |
| 2048X1080PS F25 | 1.896:1 | 2048X1080 | 1920X1013 | 1946X1026 | 1920X1013 | 2048X1080 | 1824X962 | 2048X1080 |
| | 2.39: 1 | | 1920X803 | | 1920X803 | | 1824X763 | |
| 2048X1080PS F30/29.97 | 1.896:1 | 2048X1080 | 1920X1013 | 1946X1026 | 1920X1013 | 2048X1080 | 1824X962 | 2048X1080 |
| | 2.39: 1 | | 1920X803 | | 1920X803 | | 1824X763 | |
| 2048X1080P24/23.97 | 1.896:1 | 2048X1080 | 1920X1013 | 1946X1026 | 1920X1013 | 2048X1080 | 1824X962 | 2048X1080 |
| | 2.39: 1 | | 1920X803 | | 1920X803 | | 1824X763 | |

| Input Signal | ASPECT RATIO | NORMAL SCAN | | OVER SCAN | | UNDER SCAN | | NATIVE |
|--------------------|--------------|-------------|-----------|-----------|-----------|------------|----------|-----------|
| | | Input | Output | Input | Output | Input | Output | |
| 2048X1080P25 | 1.896:1 | 2048X1080 | 1920X1013 | 1946X1026 | 1920X1013 | 2048X1080 | 1824X962 | 2048X1080 |
| | 2.39: 1 | | 1920X803 | | 1920X803 | | 1824X763 | |
| 2048X1080P30/29.97 | 1.896:1 | 2048X1080 | 1920X1013 | 1946X1026 | 1920X1013 | 2048X1080 | 1824X962 | 2048X1080 |
| | 2.39: 1 | | 1920X803 | | 1920X803 | | 1824X763 | |
| 2048X1080P48/47.94 | 1.896:1 | 2048X1080 | 1920X1013 | 1946X1026 | 1920X1013 | 2048X1080 | 1824X962 | 2048X1080 |
| | 2.39: 1 | | 1920X803 | | 1920X803 | | 1824X763 | |
| 2048X1080P50 | 1.896:1 | 2048X1080 | 1920X1013 | 1946X1026 | 1920X1013 | 2048X1080 | 1824X962 | 2048X1080 |
| | 2.39: 1 | | 1920X803 | | 1920X803 | | 1824X763 | |
| 2048X1080P60/59.94 | 1.896:1 | 2048X1080 | 1920X1013 | 1946X1026 | 1920X1013 | 2048X1080 | 1824X962 | 2048X1080 |
| | 2.39: 1 | | 1920X803 | | 1920X803 | | 1824X763 | |

*Don't display all OSD when SCAN is NATIVE.

*Don't display MARKER when SCAN is NATIVE.

3. Dimensions

The description of the product dimensions is shown as in the following figures(Unit: mm):

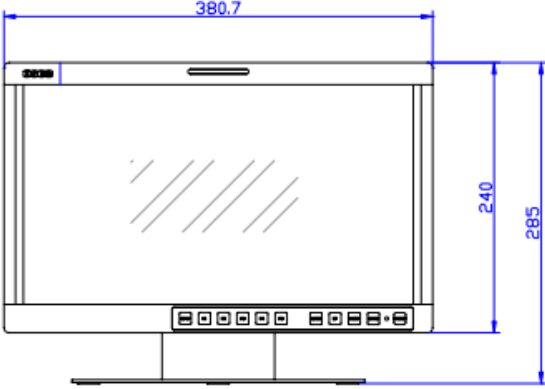
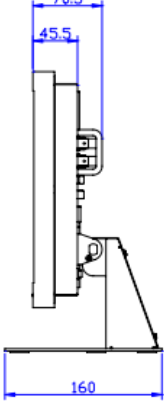
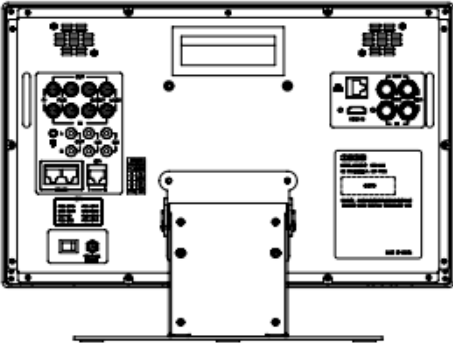
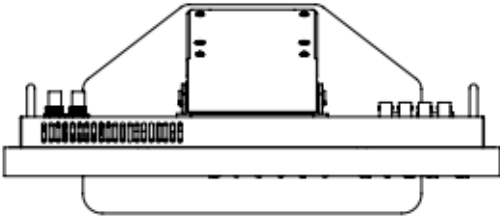
| ■ BCM-156 | |
|---|--|
| Front Panel | Side View |
|  |  |
| Rear Panel | Top View |
|  |  |

■ **BCM-170**

Front Panel

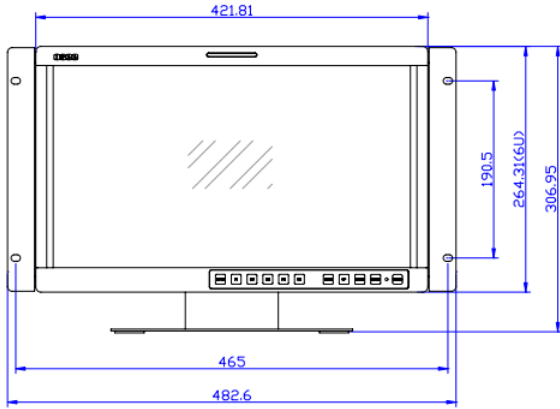

Side View

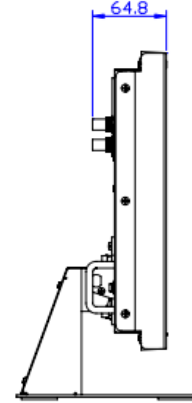

Rear Panel

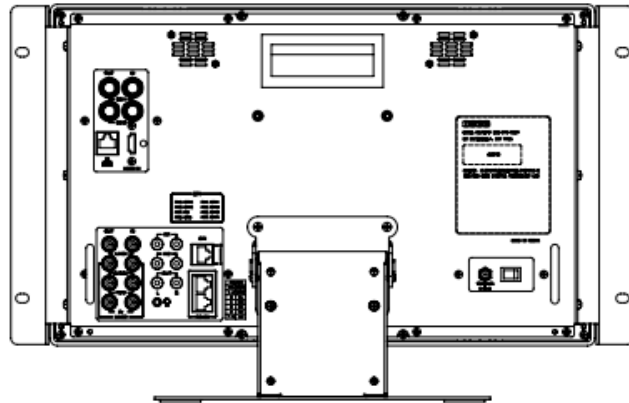

Top View

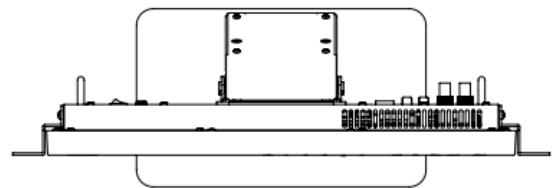

■ **BCM-215**

Front Panel

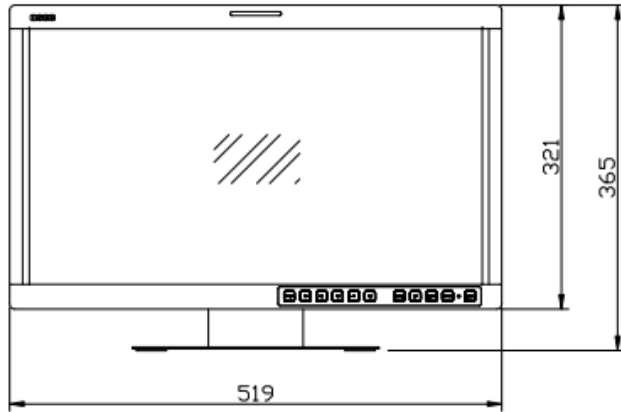

Side View

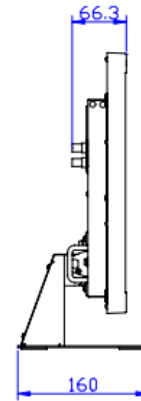

Rear Panel

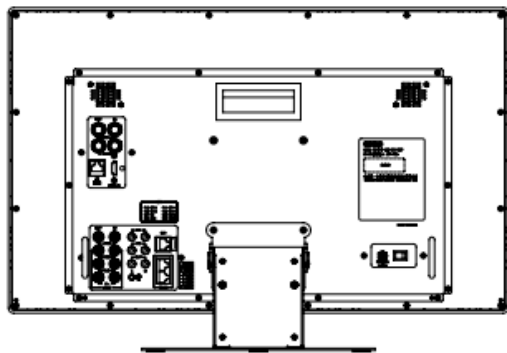

Top View

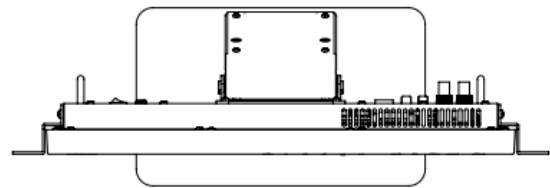

■ BCM-230

Front Panel

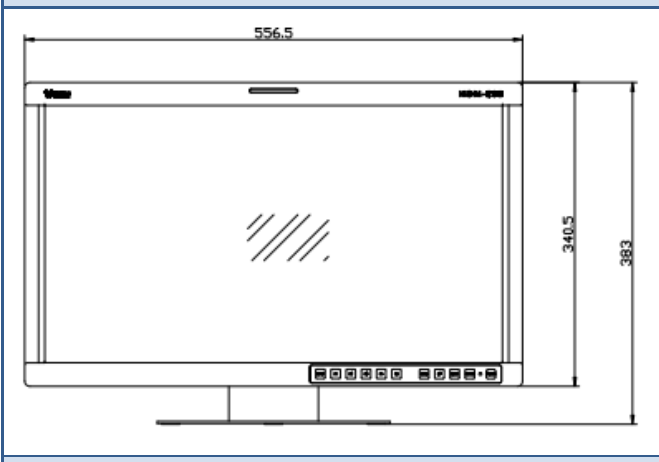

Side View

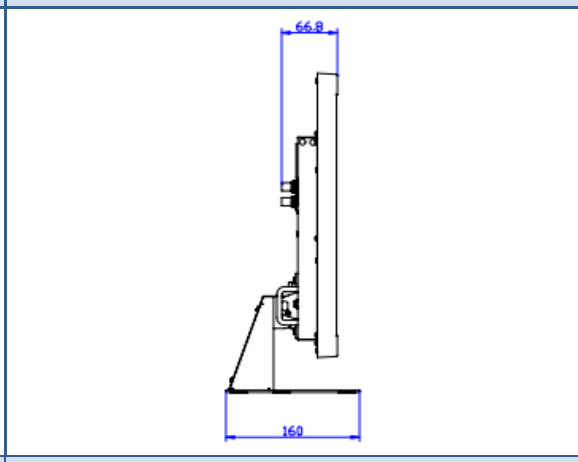

Rear Panel

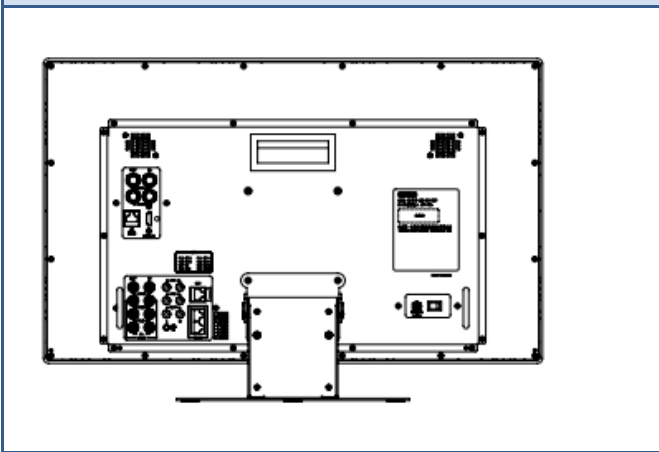

Top View

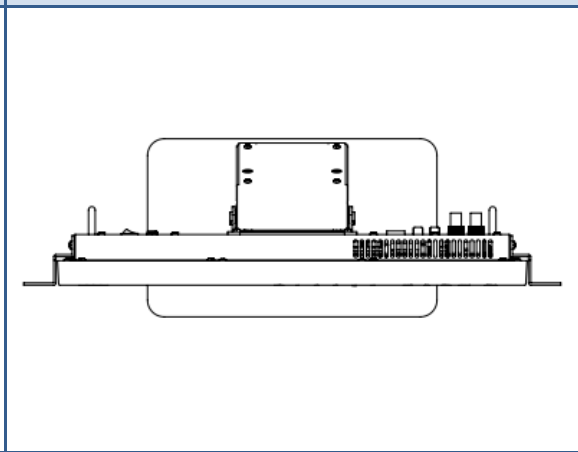

i Tips

- Specifications are subject to change without notice.

-----No Text Below-----



FOR MORE INFORMATION PLEASE VISIT: <http://www.osee-dig.com/>
OSEE TECHNOLOGY CO., LTD.
No.22 Building, No.68 zone, Beiqing Road, Haidian District, Beijing, China
Tel: (+86) 010-62434168, Fax: (+86) 010-62434169
E-mail: sales@osee-dig.com