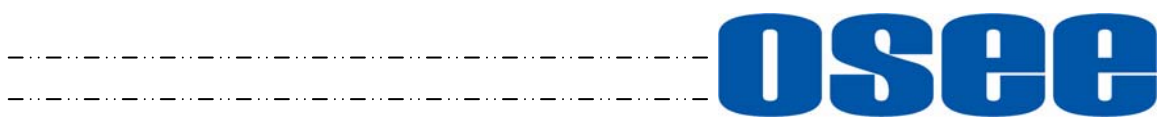


# **PRM1014 Monitor**

## **User Manual**





**Product Information**

MODEL: PRM1014 Monitor  
VERSION: V010100  
RELEASE DATE: June 21th, 2016

---

**Company**

OSEE TECHNOLOGY CO., LTD.

---

**Contact Information**

Address: No.22 Building, No.68 zone, Beiqing Road, Haidian District, Beijing, China  
Post Code: 100094  
Tel: 010-62434168  
Fax: 010-62434169  
<http://www.osee-dig.com/>  
E-mail: [sales@osee-dig.com](mailto:sales@osee-dig.com)

# About this manual

## Important

The following symbols are used in this manual:

### **Tips**

---

- The further information or know-how for described subjects above which helps user to understand them better.
- 

### **Warning**

---

- The safety matters or operations that user must pay attention to when using this product.
- 

## Contents

The user manual applies to the following device types:

- ❖ **PRM1014-3HSV**
- ❖ **PRM1014-HSV**
- ❖ **PRM1014-SV**

The images of PRM1014-3HSV are adopted in the following descriptions. Any of the different specifications between the device types are elaborated. Before reading the manual, please confirm the device type.

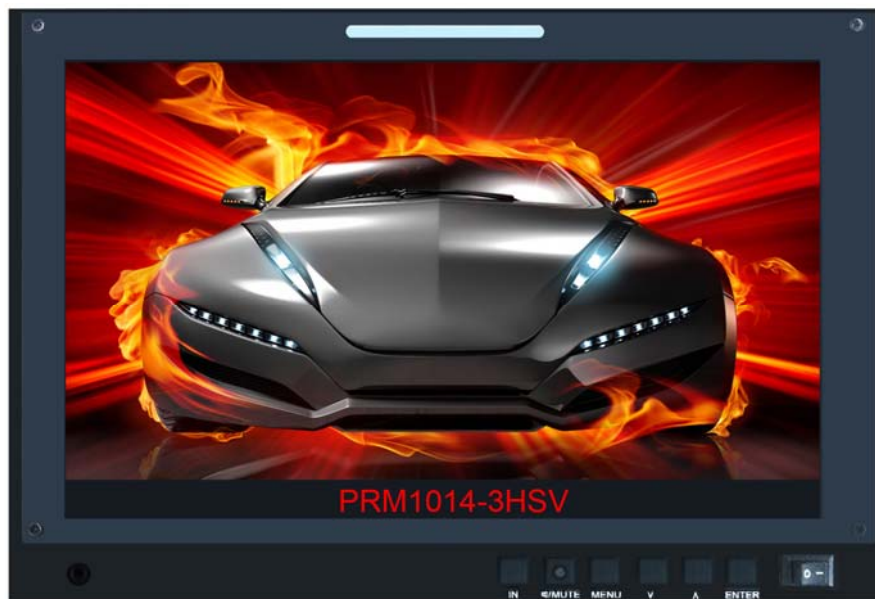
## Contents

<b>Contents</b> .....	<b>I</b>
<b>Chapter 1 Overview</b> .....	<b>1</b>
<b>Chapter 2 Safety</b> .....	<b>3</b>
<b>Chapter 3 Unpack and Installation</b> .....	<b>7</b>
<b>Chapter 4 PRM1014 Features</b> .....	<b>9</b>
<b>4.1 Front Panel Features</b> .....	<b>11</b>
4.1.1 Arrangement of Front Panel .....	11
4.1.2 Operation of Front Panel .....	12
<b>4.2 Rear Panel Features</b> .....	<b>17</b>
4.2.1 Arrangement of Rear Panel .....	17
4.2.2 Operations of Rear Panel .....	18
<b>4.3 Supported Signal Format</b> .....	<b>20</b>
<b>Chapter 5 Functionality of the Main Menu</b> .....	<b>23</b>
<b>5.1 Main Menu</b> .....	<b>23</b>
5.1.1 STATUS Menu .....	25
5.1.2 INPUT SELECT Menu .....	27
5.1.3 MARKER Menu .....	29
5.1.4 AUDIO Menu .....	33
5.1.5 DISPLAY Menu .....	36
5.1.6 CLOSED CAPTION Menu .....	39
5.1.7 CONFIG Menu.....	40
5.1.8 COLOR TEMP Menu .....	45
5.1.9 FUNCTION KEY Menu .....	47
5.1.10 IMD Menu .....	49
<b>5.2 Menu Settings</b> .....	<b>64</b>
<b>Chapter 6 Network Control</b> .....	<b>69</b>
<b>6.1 Access the settings</b> .....	<b>69</b>
<b>6.2 Menu Control</b> .....	<b>70</b>
6.2.1 ADJUST Menu.....	72
6.2.2 VIDEO DISPLAY Menu .....	73
6.2.3 SYSTEM Menu .....	74
6.2.4 Other Menus .....	75
<b>6.3 Parameter Settings</b> .....	<b>75</b>

**Chapter 7 Specifications .....79**

## Chapter 1 Overview

PRM1014 is a 10.1", single screen, high full HD portable monitor. It has a dedicate and simple outlook, and offers a full resolution 1920X1200 LCD panel, with wide viewing angle and wide color gamut. It supports the video signal of analog composite/3G/HD/SD-SDI and HDMI. It supports analog audio input/output. It supports precise color correction, audio meter display, wave form, vector and so on.



**Figure 1 A Diagram of PRM1014**

### Features

- Supports 3G/HD/SD-SDI, analog composite video signal and HDMI 1.3a
- Offers LCD panel with resolution of 1920 X1200, high-brightness, high-contrast and 178° wide viewing angle
- Supports color gamut modes that meet the criteria of SMPTE-C, EBU, ITU-709
- Supports various color temperature and user customized color temperature
- Supports multiple power supply modes: AC adapter, external battery
- Presets external battery plate, and supports various battery plates(SONY F-970, Panasonic D54S, Canon LP-E6)

## Functionality

- Audio phase meter and phase alarm display
- 16 channels embedded audio level meter, the channel number and the dB value can be displayed
- Supports various markers: Center Marker, Area Marker and Safety Marker
- Supports TSL/IMAGE VIDEO dynamic TALLY protocol
- Supports TC code(VITC, LTC, D-VITC)
- Supports AFD prompts display
- Supports H/V Delay, NATIVE, BLUE ONLY, MONO
- Speaker and earphone output
- Supports Ethernet control
- 3G supports 1080P 50, 1080P 60



## **Chapter 2 Safety**

### **FCC Caution:**

Any Changes or modifications not expressly approved by the party responsible for compliance could void the user's authority to operate the equipment.

This device complies with part 15 of the FCC Rules.

Operation is subject to the following two conditions: (1) This device may not cause harmful interference, and (2) this device must accept any interference received, including interference that may cause undesired operation.

Note: This equipment has been tested and found to comply with the limits for a Class B digital device, pursuant to part 15 of the FCC Rules. These limits are designed to provide reasonable protection against harmful interference in a residential installation. This equipment generates uses and can radiate radio frequency energy and, if not installed and used in accordance with the instructions, may cause harmful interference to radio communications. However, there is no guarantee that interference will not occur in a particular installation. If this equipment does cause harmful interference to radio or television reception, which can be determined by turning the equipment off and on, the user is encouraged to try to correct the interference by one or more of the following measures:

Reorient or relocate the receiving antenna.

Increase the separation between the equipment and receiver.

Connect the equipment into an outlet on a circuit different from that to which the receiver is connected.

Consult the dealer or an experienced radio/TV technician for help.

## Warnings:

Read, keep and follow all of these instructions for your safety. Heed all warnings.

### Warning

---

#### Monitor

- Do not beat with a hard object or scratch the LCD display.
  - Do not make the freeze picture displaying on the screen time too long, otherwise, it will leave the afterimage on the screen.
  - Install in accordance with the manufacturer's instructions.
  - If the brightness is adjusted to the minimum, then it might be hard to see the display screen.
  - Refer all servicing to qualified service personnel. Servicing will be required under all of the following conditions:
    - The unit has been exposed to rain or moisture.
    - Liquid had been spilled or objects have fallen onto the unit.
    - The unit has been damaged in any way, such as when the power-supply cord or plug is damaged.
    - The unit does not operate normally.
  - Clean only with dry cloth.
  - Specifications are subject to change without notice.
- 

### Warning

---

#### Position

- Do not block any ventilation openings.
- Do not use this unit near water.
- Do not expose the unit to rain or moisture.
- Do not use this unit near any heat sources such as radiators, heat

registers, stoves, or other apparatus (including amplifiers) that product heat.

- A nameplate indicating operating voltage, etc., is located on the rear panel.
  - The socket-outlet shall be installed near the equipment and shall be easily accessible.
- 

## **Warning**

---

### **Power Supply Cord**

- Do not defeat the safety purpose of the polarized or grounding-type plug.
  - Do not damage the power cord, place the heavy objects on the power cord, stretch the power cord, or bend the power cord.
  - Protect the power cord from being walked on or pinched, particularly at plugs, convenience receptacles, and the point where they exit from the unit.
  - If the power cord is damaged, turn off the power immediately. It is dangerous to use the unit with a damaged power cord. It may cause fire or electric shock.
  - Unplug this unit during lightning storms or when unused for long periods of time.
  - Disconnect the power cord from the AC outlet by grasping the plug, not by pulling the cord.
  - Should any solid object or liquid fall into the cabinet, unplug the unit and have it checked by qualified personnel before operating it any further.
-

02222222

## Chapter 3 Unpack and Installation

### Unpack:

When unpacking the components of PRM1014 monitor, please verify that none of the components listed in Table 3.1 are damaged or lack. If there is any missing, contact your dealers or OSEE TECHNOLOGY CO., LTD. for it.

**Table 3.1 Packing List**

No.	Item	Quantity
1	Monitor	1
2	Power cord	1
3	Power adapter	1
4	Battery plate(optional)	1/2
5	User manual	1
6	warranty card	1
7	Certificate Card	1

### Installation:

#### 1. Prepare for installation

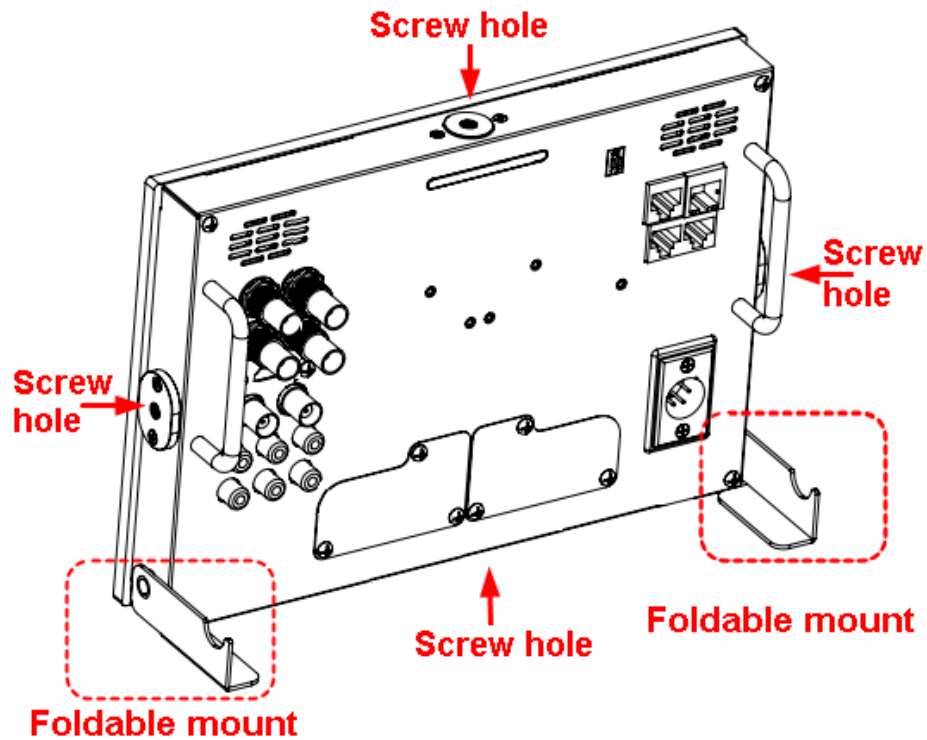
Please follow the procedures below before installing PRM1014 monitor:

- Check the equipment for any invisible damage that may have occurred during transit.
- Confirm all the items listed on the packing list have been received.
- Remove all the packing material including electrostatic-resistant packing.
- Retain these packing for future use.

#### 2. Install PRM1014 in your desired location of an equipment rack.

Adequate ventilation is required when installed to prevent possible damage to the PRM1014 internal components.

There are screw holes at the center position of each surrounding sides, which are labeled an arrow in the following figure, and there are foldable mounts for support the monitor.



3. Connect required cables for signal input and output. For BNC connections use  $75\ \Omega$  rated connectors.
4. Connect power source using the included power cord.
5. Connect the power cord to the rear panel.
6. Fasten the power protect accessory.
7. As a final step, turn on each screen of the PRM1014 by pressing the corresponding power switch located on the front panel.

## Chapter 4 PRM1014 Features

This chapter describes the features of PRM1014 monitor. The features of PRM1014 monitor are as shown in Figure 4-1 after installed and powered on:

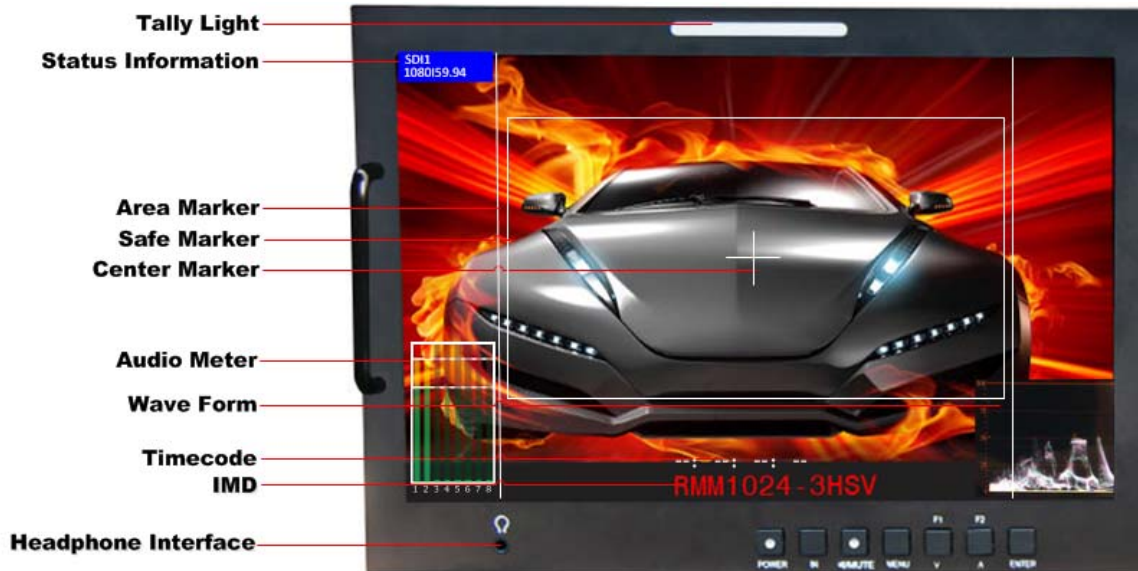
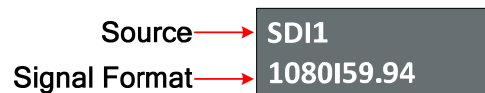



Figure 4-1 Features of PRM1014 Monitor

1. **Tally light:** this LED light is at the top center of the front panel, and you can judge the monitor status by the color of Tally light. This tri-color (red/green/amber) light is controlled through a RJ45 connector on the rear panel.
2. **Status Information:** it is displayed in the top left corner of the screen, and includes the input channel and signal format. You can define it in DISPLAY menu.



3. **Waveform and Vector:** this is effective only for SDI signal. The waveform and vector of the input signal are configurable in the MAIN Menu.
4. **Area Marker:** it is used to mark different area of the image. You can set whether to display it or not and their displaying mode in **MARKER** menu.
5. **Safe Marker:** it is used to mark different area of the image. You can set whether to display it or not and their displaying mode in **MARKER** menu

6. **Center Marker:** it is displayed in the center of the screen, and marks the center of the image. You can set whether to display it or not in **MARKER** menu.
7. **Audio Meter:** it is displayed for audio monitoring. You can set its groups, direction, position and mode in **AUDIO** menu.
8. **Timecode:** it is displayed at the bottom of the image, the format is HH:MM:SS:FF, if there is no timecode available, the monitor will display --:--:--:--.
9. **IMD:** the IMD text displays at the bottom of the screen, the length can't exceed 16 characters, and you can choose letter, number or other character for it.
10. MUTE

The icon for MUTE is . When it is mute, this icon displays at the bottom right position of the screen. You can set this function in function key.

11. **Headphone Interface:** The  $\Omega$  icon as shown in Screen No.1 is the headphone interface, it supports 3.5mm stereo, and the two screen share one headphone interface.

## Tips

---

- The **Status Information** usually displays as the following situations:
    - "UNKNOWN" appears if an unsupported signal is input.
    - "NO SIGNAL" appears if no signal is input.
    - The signal is normal, for example: 1080i59.94, NTSC, 1280X1024, etc.
  - The **Status Information** for the main picture displays at the top left corner of the screen, and the **Status Information** for the slave picture displays at the top right corner of the screen.
  - The AFD information displays at the top center of the screen.
-

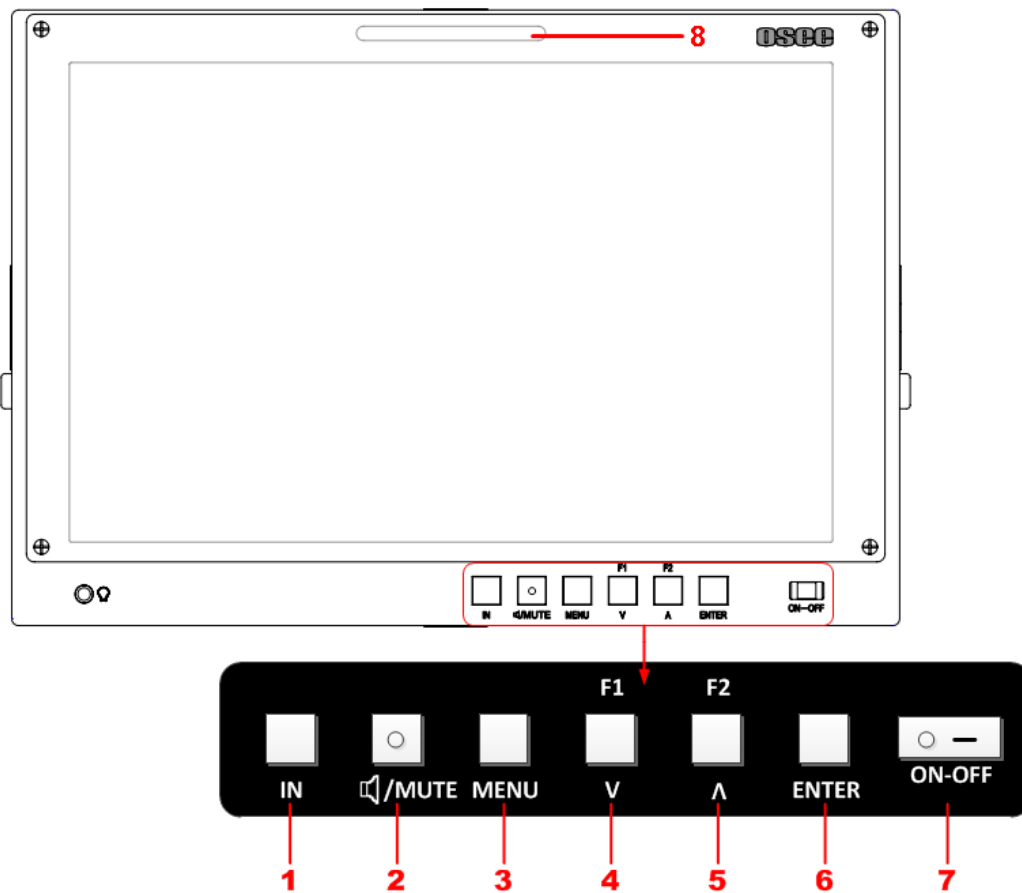


## 4.1 Front Panel Features

It will introduce the arrangement and the operations of the buttons in front of the panel in the following.


### 4.1.1 Arrangement of Front Panel

There are a series of buttons at the bottom of the screen.



**Figure 4.1-1 the Buttons in Front Panel**

As shown in Figure 4.1-1, the buttons labeled in numbers are described as follows:

1. **IN**
2.  **/MUTE**
3. **MENU**
4. **F1/V**

5. F2/∧
6. ENTER
7. Power
8. Tally Light(Front)

## Tips

---

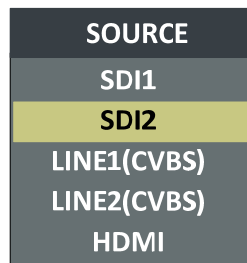
- Only the /MUTE button has a light indicator.
- 

### 4.1.2 Operation of Front Panel

The functionality and usage of the buttons at the front panel are as follows:

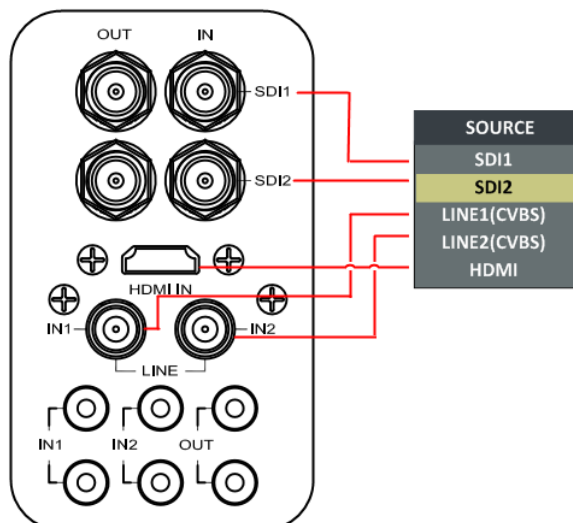
#### 1. IN

Select the input signal. Press this button to display the source menu at the right top corner of the screen, as shown in Figure 4.1-2. Use it to select an input signal source, press it again to toggle among these input signal items.



**Figure 4.1-2 Source Menu**

The one-to-one correspondence between the signals in the source menu list and the interfaces in the back panel are shown in Figure 4.1-3:



**Figure 4.1-3 Correspondence between Source Menu and Interface**

2. /MUTE

This button can achieve the following two functions:

- : Audio monitor button. Toggle this button to enable or disable the audio monitor, and the light in the button will indicate the status of audio monitoring. When the light is on, the audio is monitoring, and when the light is off, it is mute. The volume is adjusted in adjust menu.
- **MUTE**: Audio mute button. Toggle this button to enable or disable the audio monitor.



**Figure 4.1-4 Audio Monitor Menu**

**Tips**

- After you have loaded the Audio Monitor Menu, it will be closed automatically if you do nothing operation with it in 10s.

**3. MENU**

It is used to activate the Main menu. Press this button to do some operations with the Main menu, it includes the following operations:

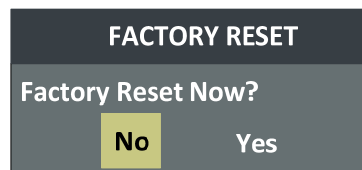
- Display the Main menu

- Back to the higher level menu
- Quit the Main menu

Refer to “5.2 Menu Settings” for detail about the main menu operations.

## Tips

- Press and hold the **MUTE+ENTER** button for 3s can reset the menu settings to factory originals, as shown in Figure 4.1-5.



**Figure 4.1-5 Reset Menu List**

### 4. F1/∨

This button can achieve the following two functions:

- **F1**: F1 function button. Press **F1** to display the function menu list in the center of the screen, as shown in Figure 4.1-6. Toggle **F1** button to change the value related to this function.
- **∨**: it is **Down** button when working with **MENU**. Toggle this button to select the next item or decrease the number.

FUNCTION		
F1	MUTE	OFF
F2	NATIVE	OFF

**Figure 4.1-6 Function Menu List**

## Tips

- After you have loaded the function menu list, it will be closed automatically if you do nothing operation with it in 10s.
- If the value related to the function button can't be modified, the value shows in blue.
- Use **FUNCTION KEY** menu to assign F1 and F2. You can assign F1/F2 the function from among: SCAN, NATIVE, ASPECT, BLUE ONLY, MONO,

MARKER, H/V DELAY, AUDIO METER, FAST MODE, TC, IMD, MUTE, PBP, CC, FREEZE, WIN SELECT, FOCUS ASSIST, LUMA ZOOM CHECK, UNDEF. Refer to "5.1.9 FUNCTION KEY Menu" for the details.

## 5. F2/∧

This button can achieve the following two functions:

- **F2:** F2 function button. Press **F2** to display the function menu list in the center of the screen, toggle **F2** button to change the value related to this function.
- **∧:** it is **Up** button when working with **MENU**. Toggle this button to select the next item or increase the number.

FUNCTION		
F1	MUTE	OFF
F2	NATIVE	OFF

**Figure 4.1-7 Function Menu List**

## 6. ENTER

This button can achieve the following two situations:

- **Work with the Main MENU:** when working with the Main menu, ENTER button achieve the following functions:
  - Enter into the next level menu: press **ENTER** button, you will enter into the menu item as this relationship: the Main menu list → sub-menu list → sub-menu value list, the current editable object is in yellow control icon;
  - Confirm the value selection: press **ENTER** button to confirm the value selection.
- **Adjust Menu:** when not displaying the Main menu, press **ENTER** button to display the adjust menu list, as shown in Figure 4.1-8, toggle among these menu items: VOLUME, BRIGHTNESS, CONTRAST, CHROMA.



**Figure 4.1-8 Adjust Menu List**

After displaying the Adjust menu, press **∧(Up)** or **∨(Down)** button to adjust the menu value, and then press **ENTER** button to confirm the value

selection.

The relationship of the menu items and their range is shown in Table 4.1-1:

**Table 4.1-1 The Description of Adjust Menu Items**

Adjust Menu	Description	Range	Default
VOLUME	Adjust the volume	0~31dB	16
BRIGHTNESS	Adjust the image brightness	0~100	50
CONTRAST	Adjust the image contrast	0~100	50
CHROMA	Adjust the image monochroma	0~100	50

### Tips

- Set these parameter value in the following position: BRIGHTNESS, CONTRAST, CHROMA.
  - In Adjust Menu List on screen when pressing Enter key.
  - In Adjust menu of network control page.
- After you have loaded the adjust menu list, it will be closed automatically if you do nothing operation with it in 10s.
- The main menu, the adjust menu, the function menu and the input signal selection list of a screen may not be shown all simultaneously.

## 7. Power

Used to power on or standby, and the light in the button will indicate the status of the power. If the light is green, the monitor is powered on, if the light is flashing, the monitor is standby.

### Tips

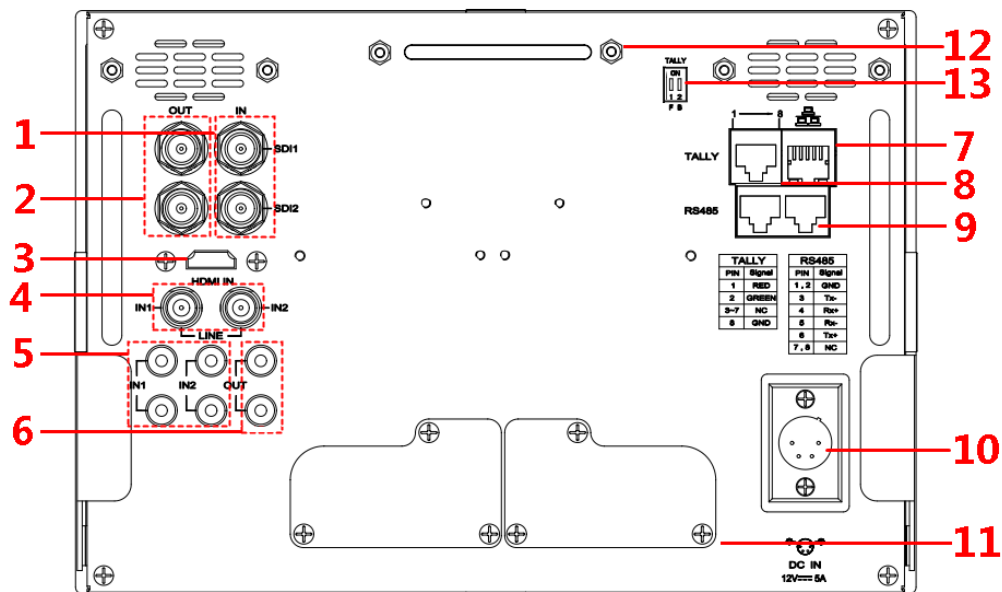
- When the device is standby, cut off the power and restart the device, the status of the device will be normal but not standby.

## 4.2 Rear Panel Features

It will introduce the arrangement and the operations of the interfaces in rear of the panel in the following.

### 4.2.1 Arrangement of Rear Panel

As shown in Figure 4.2-1, there are various input and output interfaces at the rear panel of PRM1014 monitor.



**Figure 4.2-1 The Rear Panel of PRM1014 Monitor**

The interfaces numbered from 1 to 8 in red dotted rectangle are described as follows:

1. Video Input
2. Video Output
3. HDMI Input
4. Video Input
5. Audio Output
6. Audio Input
7. Ethernet
8. Tally Input
9. RS485 In/Out
10. Power Input

11. Battery Plate
12. Tally Light(Back)
13. Tally Switch

## 4.2.2 Operations of Rear Panel

The details of these interfaces at the rear panel are described as follows:

### 1. Video Input Interface (BNC)

It provides two SDI input interfaces, one is labeled as SDI1 IN, and the other is SDI2 IN, 800mVp-p +/-10%.

### 2. Video Output Interface (BNC)

It provides two SDI output interfaces. One is labeled as SDI1 OUT, the other is SDI2 OUT, 800mVp-p +/-10%, active loop.

### 3. HDMI

It provides one HDMI input interface, HDMI Type-A connector with a fastener.

### 4. Video Input Interface (BNC)

It provides two SDI input interfaces. One is labeled as LINE IN1, and the other is LINE IN2, 1Vp-p +/-3dB, sync negative.

### 5. Audio Output interface

It provides two audio output interfaces, 5dBu, impedance  $\leq 500 \Omega$ , RCA connector.

### 6. Audio Input interface

It provides four audio input interfaces, 5dBu, impedance  $\geq 47K$ , RCA connector.

### 7. Ethernet (RJ-45)

It provides one 10/100M Ethernet connector. It is used to connect with a computer to modify the network settings.

### 8. Tally(DB9)

It controls the LED tally light.

The relationship of the pins of Tally interface and its channel value is shown in Table 4.2-1.

**Table 4.2-1 The Relationship of Tally Input Pins and Channel Values**

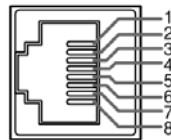


Pin No.	Channel Value
Pin 1	RED
Pin 2	GREEN
Pin 3~7	NC
Pin 8	GND

**i Tips**

- Tally light is in working status when grounding.

9. IN/ OUT RS485 Interface (RJ-45)



Support for dynamic UMD and updating the new firmware.  
 The Comparison of Pins and Input/output connectors for RS485 is shown as in Table 4.2-2:

**Table 4.2-2 The Comparison of Pins and Input/output connectors for RS485**

PIN No.	RS485 IN Terminal Signal	RS485 OUT Terminal Signal
1,2	GND	GND
3	Tx-	Tx-
4	Rx+	Rx+
5	Rx-	Rx-
6	Tx+	Tx+
7,8	NC	NC

10. Power Input

It provides a 4-pins cannon power input interface, the specification is 5A12VDC. The corresponding indicator is at the front panel. If the light is green, the monitor is powered on, if the light is flashing, the monitor is standby, and if the light is off, the monitor is powered off.

**Warning**

- Only use the adapter and the power cord specified by the manufacture for your safety!

### 11. Battery Plate

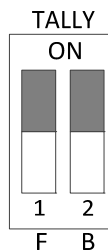
It provides battery plate as optional accessory for PRM1014, thus, you can use external batteries as the power supply for PRM1014, and you can select two types according to the amount of the battery plates: one battery plate or two battery plates. Refer to “Chapter 7 Specifications” for the details about the optional accessories.

### 12. Tally Light(Back)

There is a back tally light at the top of the rear panel, and controlled by combination relationship of Tally input and tally switch.

### 13. Tally Switch

There is a group of tally dip switch, as shown in Figure 4.2-2:



**Figure 4.2-2 Tally Switch of PRM1014 Monitor**

The dip is white, and it is on the ON character side that the corresponding tally light will be lit up.

The front Tally light is controlled by No.1 Dip labeled with a letter F for short, and the back Tally light is controlled by No.2 Dip labeled with a letter B. When you dial the two dials to different position, the corresponding tally light will be in different status, the relationship is shown in Table 4.2-3:

**Table 4.2-3 The Relationship of Tally Light and Tally Switch**

Tally Switch	Screen 1		Screen 2	
	ON	OFF	ON	OFF
Tally Light-Front	Light ON	Light OFF	Light OFF	Light OFF
Tally Light-Back	Light OFF	Light OFF	Light ON	Light OFF

## 4.3 Supported Signal Format

The supported signal format for this device is as shown in Table 4.3-1:

**Table 4.3-1 Supported Signal Format**

	<b>SDI</b>	<b>VIDEO</b>	<b>HDMI</b>
PAL		✓	
NTSC		✓	
480I60/59.94	✓		✓
576I50	✓		✓
480P60/59.94			✓
576P50			✓
720P24/23.97	✓		
720P25	✓		✓
720P30/29.97	✓		✓
720P50	✓		✓
720P60/59.94	✓		✓
1080SF24/23.97	✓		✓
1035I60/59.94	✓		✓
1080I50	✓		✓
1080I60/59.94	✓		✓
1080P24/23.97	✓		✓
1080P25	✓		✓
1080P30/29.97	✓		✓
1080P50	✓		✓
1080P60/59.94	✓		✓
VGA(640X480)			✓
SVGA(800X600)			✓
XGA(1024X768)			✓
SXGA(1280X1024)			✓
WXGA(1360X768)			✓
WXGA+(1440X900)			✓
WXGA+(1400X1050)			✓
UXGA(1600X1200)			✓
UXGA+(1680X1050)			✓
WUXGA(1920X1080)			✓
WUXGA(1920X1200)			✓

032222

## Chapter 5 Functionality of the Main Menu

This chapter describes the structure and functionality of the main menu, and introduces how to modify and customize the menu settings.

The main menu includes the following menu items, as shown in Figure5-1.

MAIN	STATUS
STATUS	INPUT SDI1
INPUT SELECT	FORMAT NO SIGNAL
MARKER	COLOR TEMP D65
AUDIO	SCAN MODE OVER
DISPALY	FAST MODE OFF
CLOSED CAPTION	MODEL PRM1014-3HSV
CONFIG	SERIAL NUMBER PRM10142015010001
COLOR TEMP	IP ADDRESS 192.168.1.86
FUNCTION KEY	COLOR VERSION 2015 -1 -5.4
IMD	

Figure 5-1 Main Menu

### 5.1 Main Menu

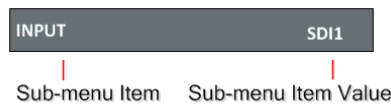
Press the **MENU** button at the bottom of the front panel, the main menu is displayed at the top left corner of the screen, as shown in Figure 5.1-1:

MAIN	STATUS
STATUS	INPUT SDI1
INPUT SELECT	FORMAT NO SIGNAL
MARKER	COLOR TEMP D65
AUDIO	SCAN MODE OVER
DISPALY	FAST MODE OFF
CLOSED CAPTION	MODEL PRM1014-3HSV
CONFIG	SERIAL NUMBER PRM10142015010001
COLOR TEMP	IP ADDRESS 192.168.1.86
FUNCTION KEY	COLOR VERSION 2015 -1 -5.4
IMD	

Figure 5.1-1 the Structure of the Main Menu

The menu interface is divided into three parts:

1. Main Menu List: it contains the several sub-menu items. The title of this list is **MAIN**. Press **Up**(^) or **Down**(v) to access the corresponding menu item.
2. Sub-menu value list: as shown in Figure 5.1-2, it lists the control icon, sub-menu item and the value of the item. After pressing **Menu** button, press **Up**(^), **Down**(v) button and **Enter** button to modify the value of the sub-menu. Refer to “5.2 Menu Settings” for details.



**Figure 5.1-2 the Sub-menu Value List**

**i Tips**

- The sub-menu item is selected when the control icon which is in yellow highlight is at the back of the item name.
- The sub-menu item value is editable when the control icon which is in yellow highlight is at the back of the item value.

The control icon of the main menu has the following status when in different positions, as shown in the red rectangle of the following figures:

- when in the main menu, it shows that this menu item is selected, as shown in Figure 5.1-3:

MAIN	INPUT SELECT
STATUS ▶	SDI1 ON
INPUT SELECT ▶	SDI2 ON
MARKER ▶	LINE1 ON
AUDIO ▶	LINE2 ON
DISPALY ▶	HDMI ON
CLOSED CAPTION ▶	NTSC SETUP 7.5
CONFIG ▶	NTSC PHASE 0
COLOR TEMP ▶	FOCUS ASSIST OFF
FUNCTION KEY ▶	FOCUS LEVEL 50
IMD ▶	FOCUS COLOR RED
	LUMA ZOOM CHECK OFF
	LUMA ZOOM LEVEL 50

**Figure 5.1-3 A Main Menu Item Is Selected**

- when in the sub-menu item, it shows that this sub-menu item is selected, and the control icon is displayed as a yellow rectangle in front of it, as shown in Figure 5.1-4:

MAIN	INPUT SELECT	
STATUS	SDI1	ON
<b>INPUT SELECT</b>	SDI2	ON
MARKER	LINE1	ON
AUDIO	LINE2	ON
DISPALY	HDMI	ON
CLOSED CAPTION	NTSC SETUP	7.5
CONFIG	NTSC PHASE	0
COLOR TEMP	FOCUS ASSIST	OFF
FUNCTION KEY	FOCUS LEVEL	50
IMD	FOCUS COLOR	RED
	LUMA ZOOM CHECK	OFF
	LUMA ZOOM LEVEL	50

**Figure 5.1-4 A Sub-menu Item Is Selected**

- when in the sub-menu item value, it shows that this sub-menu item value is selected, and the value is displayed in yellow, as shown in Figure 5.1-5:

MAIN	INPUT SELECT	
STATUS	SDI1	<b>ON</b>
<b>INPUT SELECT</b>	SDI2	ON
MARKER	LINE1	ON
AUDIO	LINE2	ON
DISPALY	HDMI	ON
CLOSED CAPTION	NTSC SETUP	7.5
CONFIG	NTSC PHASE	0
COLOR TEMP	FOCUS ASSIST	OFF
FUNCTION KEY	FOCUS LEVEL	50
IMD	FOCUS COLOR	RED
	LUMA ZOOM CHECK	OFF
	LUMA ZOOM LEVEL	50

**Figure 5.1-5 A Sub-menu Item Value Is Selected**

The following will introduce the contents and functionality of these sub-menu items in sorts.

### 5.1.1 STATUS Menu

The STATUS menu items are used to describe the current status

information of the monitor, the menu items are as shown in Figure 5.1-6:

MAIN		STATUS	
STATUS	▶	INPUT	SDI1
INPUT SELECT	▶	FORMAT	NO SIGNAL
MARKER	▶	COLOR TEMP	D65
AUDIO	▶	SCAN MODE	OVER
DISPALY	▶	FAST MODE	OFF
CLOSED CAPTION	▶	MODEL	PRM1014-3HSV
CONFIG	▶	SERIAL NUMBER	PRM10142015010001
COLOR TEMP	▶	IP ADDRESS	192.168.1.86
FUNCTION KEY	▶	COLOR VERSION	2015 -1 -5.4
IMD	▶		

**Figure 5.1-6 STATUS Menu**

The relationship of Items, Default Value, Domain Range and Description of the sub-item is shown in Table 5.1-1:

**Table 5.1-1 The Description of STATUS Menu Items**

Items	Default Value	Domain Range	Description
INPUT	SDI1	<ul style="list-style-type: none"> <li>SDI1</li> <li>SDI2</li> <li>LINE1(CVBS)</li> <li>LINE2(CVBS)</li> <li>HDMI</li> </ul>	Show the Input format
FORMAT	NO SGINAL	--	Show the format of the input signal
COLOR TEMP	D65	--	Show the color temperature.
SCAN MODE	NORMAL	<ul style="list-style-type: none"> <li>NORMAL</li> <li>OVER</li> <li>UNDER</li> </ul>	Show the scan mode.
FAST MODE	OFF	OFF/ON	Show the fast mode.
SD ASPECT	16:9	16:9/4:3	Show the screen Aspect Ratio.
MODEL	PRM1014-3HSV	--	Show the production model.
SERIAL	PRM10142015010001	--	Show the serial



Items	Default Value	Domain Range	Description
NUMBER			number.
IP ADDRESS	192.168.1.86	--	Show the IP address.
COLOR VERSION	2015-1-5.4	--	Show the color version according to its adjusted date.

### Tips

- The sub-menu values in **STATUS** menu can't be modified, they are displayed the actual status of the monitor.

## 5.1.2 INPUT SELECT Menu

The INPUT SELECT menu items are used to set the source of the input signals, the menu items are as shown in Figure 5.1-7:

MAIN	INPUT SELECT
STATUS ▶	SDI1 ON
INPUT SELECT ▶	SDI2 ON
MARKER ▶	LINE1 ON
AUDIO ▶	LINE2 ON
DISPALY ▶	HDMI ON
CLOSED CAPTION ▶	NTSC SETUP 7.5
CONFIG ▶	NTSC PHASE 0
COLOR TEMP ▶	FOCUS ASSIST OFF
FUNCTION KEY ▶	FOCUS LEVEL 50
IMD ▶	FOCUS COLOR RED
	LUMA ZOOM CHECK OFF
	LUMA ZOOM LEVEL 50

**Figure 5.1-7 INPUT SELECT Menu**

The relationship of Items, Default Value, Domain Range and Description of the sub-item is shown in Table 5.1-2:

**Table 5.1-2 The Description of INPUT SELECT Menu Items**

Items	Default Value	Domain Range	Description
SDI1	ON	ON/OFF	Enable/Disable SDI1 input
SDI2	ON	ON/OFF	Enable/Disable SDI2 input
LINE1	ON	ON/OFF	Enable/Disable LINE1 input
LINE2	ON	ON/OFF	Enable/Disable LINE2 input
HDMI	ON	ON/OFF	Enable/Disable HDMI input
NTSC SETUP	7.5	0/7.5	Select the NTSC mode
NTSC PHASE	0	-50~50	Set the NTSC phase
FOCUS ASSIST	OFF	<ul style="list-style-type: none"> <li>• OFF</li> <li>• STANDARD: An image with sharpened edges is displayed.</li> <li>• COLOR: Displays the intensified areas of images with color selected in FOCUS COLOR.</li> </ul>	Enable/Disable the focus assist function, and set the focus assist mode.
FOCUS LEVEL	50	0~100	Set the level of edge sharpening.
FOCUS COLOR	RED	RED/GREEN/BLUE	Set the color for the sharpened edge.
LUMA ZOOM CHECK	OFF	ON/OFF	Enable/Disable the luma zoom check function that will compare the signal luminance with the LUMA ZOOM LEVEL, and fill the relevant image area whose luminance is higher than the LUMA ZOOM LEVEL with a zebra pattern.
LUMA ZOOM LEVEL	50	0~100	Set the level of detecting luminance.

**1. FOCUS ASSIST**

The FOCUS ASSIST function is used to display images on the screen with sharpened edges to help camera focus operation. The sharpened edges are the compared area whose luminance is beyond the reference level, and the edges are displayed in the pointed color.

For example, set the **FOCUS COLOR** as RED, and set the **FOCUS LEVEL** as 80, the compared results are as shown Figure 5.1-8:

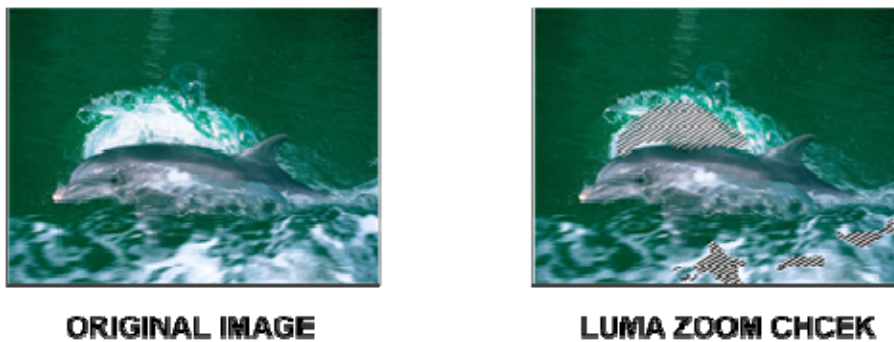


**Figure 5.1-8 Illustration for FOCUS ASSIST Function**

**2. LUMA ZOOM CHECK**

The LUMA ZOOM CHECK function is used to display images on the screen with a zebra pattern to adjust the camera exposure parameter. It will compare the signal luminance with the **LUMA ZOOM LEVEL**, and fill the relevant image area whose luminance is higher than the **LUMA ZOOM LEVEL** with a zebra pattern.

For example, set the **LUMA ZOOM LEVEL** as 80, the compared results are as shown in Figure 5.1-9, the special area is filled with a zebra pattern.



**Figure 5.1-9 Illustration for LUMA ZOOM CHECK Function**

**5.1.3 MARKER Menu**

The MARKER menu items are used to adjust the marker parameters, the menu items are as shown in Figure 5.1-10:

MAIN		MARKER	
STATUS	▶	MARKER	OFF
INPUT SELECT	▶	AREA MARKER	OFF
<b>MARKER</b>	▶	CENTER MARKER	OFF
AUDIO	▶	SAFETY MARKER	OFF
DISPALY	▶	MARKER LEVEL	1
CLOSED CAPTION	▶	MARKER MAT	OFF
CONFIG	▶	CROSS HATCH	OFF
COLOR TEMP	▶		
FUNCTION KEY	▶		
IMD	▶		

**Figure 5.1-10 MARKER Menu**

The relationship of Items, Default Value, Domain Range and Description of the sub-item is shown in Table 5.1-3:

**Table 5.1-3 The Description of MARKER Menu Items**

Items	Default Value	Domain Range	Description
MARKER	OFF	OFF/ON	Set whether to show all of the markers. It is the main switch for area marker, center marker and safety marker.
AREA MARKER	OFF	when the display aspect is 16:9, images show with the following scale: <ul style="list-style-type: none"> <li>• OFF: close area marker</li> <li>• 4:3</li> <li>• 15:9</li> <li>• 14:9</li> <li>• 13:9</li> <li>• 1.85:1</li> <li>• 2.35:1</li> </ul> when the display aspect is 4:3, images show with the following	Select the area marker aspect ratio according to the display aspect ratio.

Items	Default Value	Domain Range	Description
		scale: <ul style="list-style-type: none"> <li>• OFF: close area marker</li> <li>• 16:9</li> </ul>	
CENTER MARKER	OFF	OFF/ON	Set whether to show the center marker
SAFETY MARKER	OFF	<ul style="list-style-type: none"> <li>• OFF</li> <li>• 80%</li> <li>• 85%</li> <li>• 88%</li> <li>• 90%</li> <li>• 93%</li> <li>• 95%</li> </ul>	Set the safety area size according to the aspect ratio and scan mode.
MARKER LEVEL	1	<ul style="list-style-type: none"> <li>• 1: 50%</li> <li>• 2: 75%</li> <li>• 3: 100%</li> </ul>	Set the luminance of marker line, including safety marker, center marker, area marker and cross hatch.
MARKER MAT	OFF	<ul style="list-style-type: none"> <li>• OFF: Normal background, use line for area marker edge only</li> <li>• HALF: 50% Background brightness</li> <li>• BLACK: all black</li> </ul>	Set the transparency of area marker mat.
CROSS HATCH	OFF	OFF/ON	Set whether to show the cross hatch.

■ Markers

Marker	Illustration	Description
CENTER MARKER		This marker enables easier checking the center portion's focus.
AREA MARKER		This marker displays two lines to identify an area with a specified ratio.

Marker	Illustration	Description
SAFETY MARKER		This marker displays a rectangle to identify the safety area with a specified percentage.
CROSS HATCH		This marker displays multiple vertical and horizontal lines to help when users check the composition of a picture.

■ **MARKER MAT**

The marker mat marks the outside area of the marker display with the appointed transparency.

For example, set ASPECT as 16:9, AREA MARKER as 4:3, and SAFETY AREA as 95%, then, the comparison of the three MARKER MATs are as shown in Figure 5.1-11:



**Figure 5.1-11 MARKER MAT**

**i Tips**

- All markers will be hidden in the following modes though the corresponding marker is enabled (the value is not OFF): NATIVE, H/V DELAY, PBP.
- The AREA MARKER, CENTER MARKER and SAFETY MARKER feature are available only when the MARKER item is set to ON.
- The safety marker area will change with the area marker.
- The cross hatch lines will display only in the single image or in PIP mode when **CROSS HATCH** is **ON**.

### 5.1.4 AUDIO Menu

The AUDIO menu items are used to adjust the audio parameters, the menu items are as shown in Figure 5.1-12:

MAIN		AUDIO	
STATUS	▶	AUDIO SOURCE	AUDIO1
INPUT SELECT	▶	SPEAK OUT L	EBD CH1
MARKER	▶	SPEAK OUT R	EBD CH1
<b>AUDIO</b>	▶	AUDIO METER	OFF
DISPALY	▶	METER SELECT	CH1-2
CLOSED CAPTION	▶	METER DIRECTION	HORIZONTAL
CONFIG	▶	METER POSITION	TOP
COLOR TEMP	▶	METER DIS MODE	MODE1
FUNCTION KEY	▶	REF LEVEL	-20dB
IMD	▶	OVER LEVEL	-10dB

**Figure 5.1-12 AUDIO Menu**

The relationship of Items, Default Value, Domain Range and Description of the sub-item is shown in Table 5.1-4:

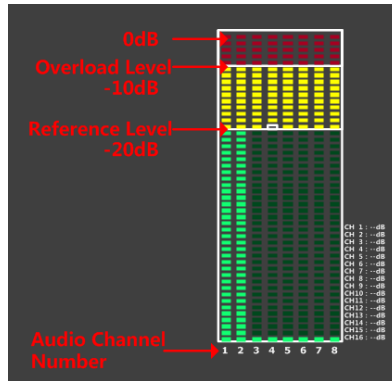
**Table 5.1-4 The Description of AUDIO Menu Items**

Items	Default Value	Domain Range	Description
AUDIO SOURCE	EDB	<ul style="list-style-type: none"> <li>• EDB: embedded signal</li> <li>• AUDIO1: external signal1</li> <li>• AUDIO2: external signal2</li> <li>• UNDEF: no signal</li> </ul>	Select the audio source. When there is no sync in and the input signal is not HDMI/SDI1/SDI2, you can select only UNDEF, AUDIO1 or AUDIO2.
SPEAK OUT L	EBD CH1	When the audio source is EBD, the range of this item is EBD CH1~ EBD CH16.	Left speaker, select a channel according to the type of audio source.
SPEAK OUT R	EBD CH2	When the audio source is EBD, the range of this item is EBD CH1~ EBD CH16.	Right speaker, select a channel according to the type of audio source.
AUDIO METER	OFF	OFF/ON	Set whether to display the audio meter.
METER	CH1-2	<ul style="list-style-type: none"> <li>• CH1-2</li> </ul>	Select a meter display

Items	Default Value	Domain Range	Description
SELECT		<ul style="list-style-type: none"> <li>• G1</li> <li>• G2</li> <li>• G3</li> <li>• G4</li> <li>• G1+G2</li> <li>• G1+G3</li> <li>• G1+G4</li> <li>• G2+G3</li> <li>• G2+G4</li> <li>• G3+G4</li> <li>• G1-G4</li> </ul>	mode. Each G* contains four channels, and each CH* means a channel with number.
METER DIRECTION	VERTICAL	VERTICAL/HORIZONTAL	Select the displayed direction of audio meter.
METER POSITION	BOT LEFT/ BOTTOM	<p>When the value of METER DIRECTION is VERTICAL, you can choose the followings for Meter Position:</p> <ul style="list-style-type: none"> <li>• BOT LEFT: bottom left</li> <li>• BOT RIGHT: bottom right</li> <li>• TOP RIGHT: top right</li> <li>• TOP LEFT: top left</li> </ul> <p>When the value of METER DIRECTION is HORIZONTAL, you can choose the followings for Meter Position:</p> <ul style="list-style-type: none"> <li>• BOTTOM</li> <li>• TOP</li> </ul>	Select the displayed position of audio meter.
METER DIS MODE	MODE1	<ul style="list-style-type: none"> <li>• MODE1: simple audio meter</li> <li>• MODE2: audio meter with channel number</li> <li>• MODE3: audio meter with channel number and dB value</li> </ul>	Select the displayed mode for audio meter.
REF LEVEL	-20dB	-20dB/-18dB	Select the reference level
OVER LEVEL	-10dB	<ul style="list-style-type: none"> <li>• -10dB</li> <li>• -8dB</li> <li>• -6dB</li> <li>• -4dB</li> <li>• -2dB</li> </ul>	Select the overload level



The appearance of Meter is as shown in Figure 5.1-13:



**Figure 5.1-13 Audio Meter**

- **METER SELECT** and **METER DIS MODE** control the operational characteristics of Audio Metering, the former controls the amount of channels displayed in a meter.

As shown in Figure 5.1-14, the meter displays at the left of the screen vertically, the **METER SELECT** is **G1+G2**, and the **METER DIS MODE** is **MODE3**, you can see the meter displays audio channel numbers and audio values beside the meter. There is a white rectangle frame with two white level lines in the meter, the upper is the over level line, and the lower is the reference level line. If the audio value is higher than the reference level, the audio bar over the reference level line will display yellow, and if the audio value is higher than the over level, the audio bar over the over level line will display red.



**Figure 5.1-14 The Position of the Audio Meter On Screen**

- The position of Meter is controlled by **METER DIRECTION** and **METER POSITION**, the position of the meter on the screen is as follows: BOT LEFT VERTICAL, BOT RIGHT VERTICAL, TOP LEFT VERTICAL, TOP RIGHT VERTICAL, BOTTOM HORIZONTAL and TOP HORIZONTAL. For example, the illustrations of some of the positions are as shown in Figure 5.1-15:

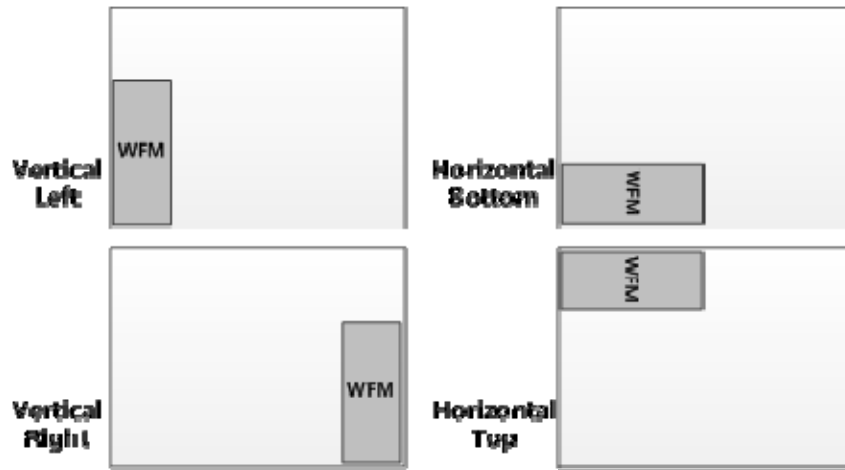


Figure 5.1-15 the Positions of Meter

- Particularly, if the **METER SELECT** is **G1-4**, there will be 16 channels displayed in audio meter, and if the **METER DIRECTION** is **Horizontal**, the audio meter will display two meters separately on both sides of the screen. One displays 8 channels(1~8) on the bottom or top left of the screen, and the other displays 8 channels(9~16) on the bottom or top right of the screen, the bottom or top is decided by **METER POSITION**, as shown in Figure 5.1-16:

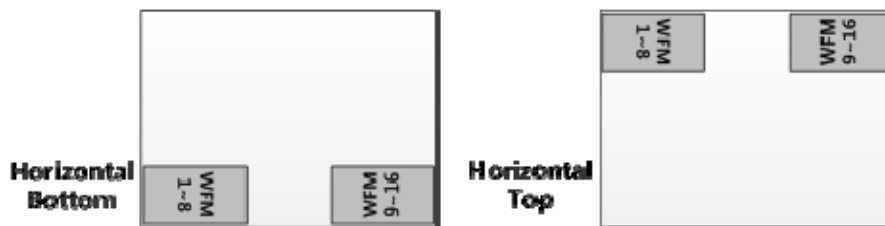


Figure 5.1-16 the Positions of the 16-channels Meter

**i Tips**

- The prerequisite for the available settings of the display mode and the position of audio meter is that the **AUDIO METER** is **ON**.

**5.1.5 DISPLAY Menu**

The DISPLAY menu items are used to adjust the parameters displayed on the screen, the menu items are as shown in Figure 5.1-17:

MAIN	DISPLAY	
STATUS	▶ STATUS DISPLAY	AUTO
INPUT SELECT	▶ AFD DISPLAY	OFF
MARKER	▶ WAVE FORM SIZE	NORMAL
AUDIO	▶ WAVE FORM TYPE	WAVE FORM
<b>DISPALY</b>	▶ LINE WAVE	OFF
CLOSED CAPTION	▶ LINE WAVE NUMBER	---
CONFIG	▶ WAVE OVER LIMIT	50
COLOR TEMP	▶ WAVE UNDER LIMIT	0
FUNCTION KEY	▶ TIME CODE	OFF
IMD	▶	

**Figure 5.1-17 DISPLAY SETUP Menu**

The relationship of Items, Default Value, Domain Range and Description of the sub-item is shown in Table 5.1-5:

**Table 5.1-5 The Description of DISPLAY SETUP Menu Items**

Items	Default Value	Domain Range	Description
STATUS DISPLAY	AUTO	OFF/ON/AUTO	Set whether to display STD information. If the signal input is not equal to "No signal" and this item is auto, the status information will show 15 seconds when the status changed, and then closed automatically.
AFD DISPLAY	OFF	OFF/ON	Set whether to display AFD information. ON is an effective value to <b>AFD DISPLAY</b> item only if the value of <b>STATUS DISPLAY</b> is AUTO or ON.
WFM FORM SIZE	NORMAL	<ul style="list-style-type: none"> <li>NORMAL: Normal size</li> <li>FULL: Full screen</li> </ul>	Set the display size of WFM/VT.
WFM FORM TYPE	NORMAL	<ul style="list-style-type: none"> <li>VECT100</li> <li>VECT75</li> <li>WAVE FORM</li> </ul>	Switch the display mode among vector100, vector75 and wave form.

Items	Default Value	Domain Range	Description
LINE WAVE	OFF	OFF/ON	Set whether to show line wave.
LINE WAVE NUMBER	260	As shown in Table 5.1-6.	Set the position of WFM.
WFM POS	BOT RIGHT	<ul style="list-style-type: none"> <li>• BOT RIGHT</li> <li>• BOT LEFT</li> <li>• TOP LEFT</li> <li>• BOT RIGHT</li> </ul>	Select the displayed position for WFM.
WFM OVERLIMIT	50	50~100	Set the over limit of WFM
WFM UNDERLIMIT	0	0~50	Set the under limit of WFM
TIME CODE	OFF	<ul style="list-style-type: none"> <li>• OFF</li> <li>• D-VITC</li> <li>• LTC</li> <li>• VITC</li> </ul>	Set whether to display TC, and select a mode for TC display.

Thereinto, the value of LINE WFM is different according to the type of input signal, as shown in Table 5.1-6.

**Table 5.1-6 The Description for LINE WFM Item**

Input Signal	Default	Domain Range
576i50	310	23~623
480i60	261	22~524
720p	386	26~745
1080i50	560	21~1123
1080i60/59.94		
1080sf23/23.97		
1035i60	557	41~1120
1080p	561	42~1121

**i Tips**

- The wave form could only be displayed in PIP mode or in PBP mode, You can call out the wave form and configure its display mode through **DISPLAY→WAVE FORM TYPE**, and configure its display position through **DISPLAY → WFM FORM SIZE**. The switch of PIP and PBP mode is controlled by **CONFIG → SUB IN TYPE** command, refer to “5.1.7

CONFIG Menu” for the details on PIP and PBP mode.

- Please refer to the international standard SMPTE2016-1-2007 for the details about AFD display.

### 5.1.6 CLOSED CAPTION Menu

The CLOSED CAPTION menu items are used to adjust the parameters displayed on the screen, the menu items are as shown in Figure 5.1-18:

MAIN		CLOSED CAPTION	
STATUS	▶	CLOSED CAPTION	CC1
INPUT SELECT	▶	SDI CC LOG	OFF
MARKER	▶		
AUDIO	▶		
DISPALY	▶		
<b>CLOSED CAPTION</b>	▶		
CONFIG	▶		
COLOR TEMP	▶		
FUNCTION KEY	▶		
IMD	▶		

**Figure 5.1-18** CLOSED CAPTION Menu

The relationship of Items, Default Value, Domain Range and Description of the sub-item is shown in Table 5.1-7:

**Table 5.1-7** The Description of CLOSED CAPTION Menu Items

Items	Default Value	Domain Range	Description
CLOSE CAPTION	OFF	CC1/CC2/CC3/CC4/ TEXT1/TEXT2/TEXT3/ TEXT4/OFF	Set whether to display caption information, and select its display mode.
SDI CC LOG	OFF	OFF/ON	Set whether to display CC information.

### 5.1.7 CONFIG Menu

The CONFIG menu items are used to adjust the parameters defined by customers, the menu items are as shown in Figure 5.1-19:

MAIN		CONFIG	
STATUS	▶	FAST MODE	OFF
INPUT SELECT	▶	FILM MODE DETECT	OFF
MARKER	▶	SUB IN TYPE	PBP
AUDIO	▶	SUB IN SELECT	SDI1
DISPALY	▶	PIP SIZE	LARGE
CLOSED CAPTION	▶	PIP POSITION	HORIZONTAL
<b>CONFIG</b>	▶	BACKLIGHT	15
COLOR TEMP	▶	AUTO STANDBY	OFF
FUNCTION KEY	▶	APPEATURE	0
IMD	▶	LOCK NUMBER	0
		LANGUAGE	ENGLISH

**Figure 5.1-19 CONFIG Menu**

The relationship of Items, Default Value, Domain Range and Description of the sub-item is shown in Table 5.1-8:

**Table 5.1-8 The Description of CONFIG Menu Items**

Items	Default Value	Domain Range	Description
FAST MODE	OFF	OFF/ON	Set whether in fast mode.
FILM MODE DETECT	OFF	OFF/ON	Set whether to detect film mode.
SUB IN TYPE	PBP	PBP/PIP/OFF	Set the arrangement mode of screen picture
SUB IN SELECT	SDI1	<ul style="list-style-type: none"> <li>• SDI1</li> <li>• SDI2</li> <li>• LINE1(CVBS)</li> <li>• LINE2(CVBS)</li> <li>• HDMI</li> <li>• WAVE FORM</li> </ul>	Set the source of slave picture, refer to Table 5.1-9 for the details.
PIP SIZE	LARGE	SMALL/LARGE	Set the size of PIP
PIP POSITION	BOT LEFT	<ul style="list-style-type: none"> <li>• BOT LEFT:</li> </ul>	Set the position of PIP

Items	Default Value	Domain Range	Description
		bottom left • BOT RIGHT: bottom right • TOP RIGHT • TOP LEFT	
BACK LIGHT	15	0~30	Adjust the back light
AUTO STANDBY	OFF	OFF/ON	Set whether open the standby mode.
APPERTURE	0	0~24	Set the picture sharpness
LOCK NUMBER	XXXXXXXX	--	Set the lock number
LANGUAGE	ENGLISH	ENGLISH/CHINESE	Select a language mode

### 1. Display Multiple Images

This monitor allows simultaneous display of two input signals on the monitor's screen. It will introduce the display mode, settings and signal source selection for the multiple images on screen as follows.

#### (1) Display Mode

This device provides four modes for picture & picture display: PIP, PBP, and the relevant relationship of the two pictures are as shown in Figure 5.1-20:

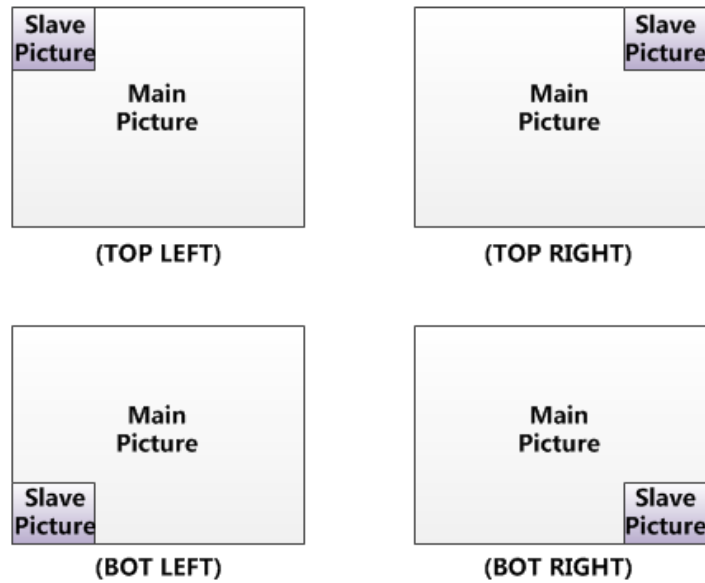


**Figure 5.1-20 Multiple Inputs**

#### ■ PIP (Picture in Picture)

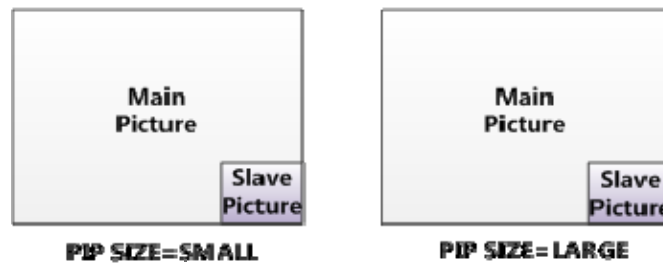
The two pictures generated by two input signals separately are displayed one in another. One is displayed on full screen, called as the main picture, and the other is displayed in an inset window, called as the slave picture. In PIP mode, the relevant position relationship of the main

picture and the slave picture is as shown in Figure 5.1-21:



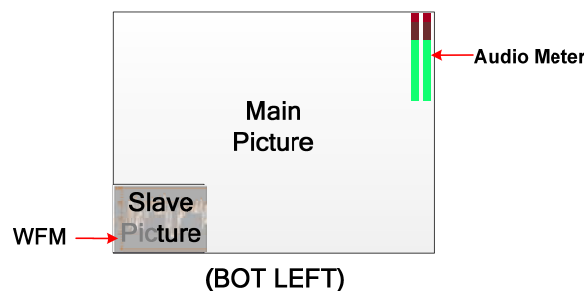
**Figure 5.1-21 The Position Relationship in PIP Mode**

And you can adjust the display size by the **PIP SIZE** item, and there are two kinds of outlines for the slave picture, as shown in Figure 5.1-22:



**Figure 5.1-22 The Size for the Slave Picture**

In PIP mode, if you set **SUB IN SELECT** to be **WAVE FORM**, it displays the WFM in the position of the slave picture, and the content of the slave picture is the WFM, as shown in **Figure 5.1-23**:

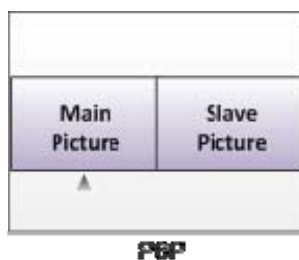


**Figure 5.1-23 The Illustrate for WFM Display**



■ **PBP**(Picture by Picture)

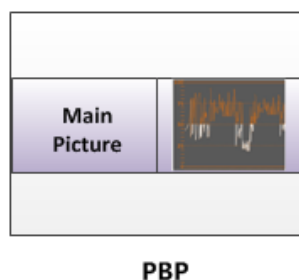
The two pictures generated by two input signals separately are displayed side by side, and this function helps with white balance adjustment, and determining shooting angles between two cameras etc. In PBP mode, the size of the main picture is as large as the slave picture is, and the position relationship of the main picture and the slave picture is as shown Figure 5.1-24:



**Figure 5.1-24 PBP Mode**

In PBP mode, it displays the WFM or Audio Meter only for the signal of the current picture. The current picture is labeled by a triangle, as shown in Figure 5.1-24, at the bottom center of the picture. You can select the current picture by the **WIN SELECT** command assigned to a function key.

In PBP mode, if you set **SUB IN SELECT** to be **WAVE FORM**, it displays the WFM in the position of the slave picture which is displayed paralleled as the slave picture, as shown in Figure 5.1-25:



**Figure 5.1-25 The Slave Picture Is Displayed as WFM**

(2) Set Display Mode

The selection for picture & picture display mode contains the following items: OFF, PBP, PIP, you can switch the selection as instructed below:

■ Method 1: By menu item.

Select the menu item **Config** → **SUB IN TYPE**, use **ENTER**, **UP** or **DOWN** key to select a display mode.

- Method 2: By function key.

Set **PBP** function to a function key (F1~F5). Select the menu item **FUNCTION KEY →F1** for example, and assign its sub-item value as PBP, as shown in Figure 5.1-26:

FUNCTION		
F1	PBP	PBP
F2	WIN SELECT	MAIN

**Figure 5.1-26 Set the Function Key as PBP**

(3) Scope for the signal source of the slave picture

The selection scope of the signal source for the slave picture will be changing with the main picture's source, as shown in Table 5.1-9:

**Table 5.1-9 The Relationship of the Signal Source for Slave Picture and Main Picture**

Signal Source for Main Picture \ Signal Source for Slave Picture	SDI1	SDI2	LINE1(CVBS)	LINE2(CVBS)	HDMI	WFM
SDI1	×	✓	✓	✓	✓	✓
SDI2	✓	×	✓	✓	✓	✓
LINE1(CVBS)	✓	✓	×	×	✓	×
LINE2(CVBS)	✓	✓	×	×	✓	×
HDMI	✓	✓	✓	✓	×	×

- Position for signal source: The input signal information of the main picture displays at the top left corner of the screen, and the one of the slave picture displays at the top right corner of the screen.
- Settings for signal source: Press **INPUT** button to set the signal source for the main picture, and select **CONFIG→SUB IN TYPE** menu item to set the signal source for the slave picture.

## 2. Auto Standby

The Auto Standby function is used to set the status of the monitor when the Power button is turned on or off.

- ON: AUTO STANDBY** is set to **ON** to enable the auto standby mode. Thus, the auto standby will be activated when detecting no signal input or signal disappeared, and there will be a prompt during the process, as shown in Figure 5.1-27:


 Going into Standby Mode

**Figure 5.1-27 Entering the Auto Standby Mode**

When detecting no signal input or signal disappeared, the power indicator will be lit in flash green for 10 seconds, and showing the standby prompt, after that, the monitor screen will be turned off, and it will be in auto standby mode, the POWER indicator is lit in green. Then, if the signal input is correct, the monitor screen will be lit up automatically.

- **OFF: AUTO STANDBY** is set to **OFF** to disable the auto standby mode.

Press **POWER** button when the monitor is in operation mode, it will power off the monitor, otherwise, press **POWER** button when the monitor is off, thus it will power on the monitor, and the **POWER** indicator is lit in green.

### Tips

---

- The length of LOCK NUMBER is up to 8 characters, you can use the combination of these characters: number (0 to 9) and letter (A to Z). Press **ENTER** to edit the LOCK NUMBER, than use **UP** or **DOWN** to select characters, than press **ENTER** to go to next character, press **MENU** to exit editor.
- 

### 5.1.8 COLOR TEMP Menu

The COLOR TEMP menu items are used to adjust the color temperature parameters and the color balance, the menu items are as shown in Figure 5.1-28:

MAIN		COLOR TEMP	
STATUS	▶	COLOR TEMP	D93
INPUT SELECT	▶	RED GAIN	128
MARKER	▶	GREEN GAIN	128
AUDIO	▶	BLUE GAIN	128
DISPALY	▶	RED BIAS	0
CLOSED CAPTION	▶	GREEN BIAS	0
CONFIG	▶	BLUE BIAS	0
<b>COLOR TEMP</b>	▶	COPY FROM	D93
FUNCTION KEY	▶	RESET	
IMD	▶	COLOR SPACE	AUTO

**Figure 5.1-28 COLOR TEMP Menu**

The relationship of Items, Default Value, Domain Range and Description of the sub-item is shown in Table 5.1-10:

**Table 5.1-10 The Description of COLOR TEMP Menu Items**

Items	Default Value	Domain Range	Description
COLOR TEMP	D65	<ul style="list-style-type: none"> <li>• USER1: Customized by user</li> <li>• USER2: Customized by user</li> <li>• D32: 3200K</li> <li>• D50: 5000K</li> <li>• D56: 5600K</li> <li>• D65: 6500K</li> <li>• D93: 9300K</li> </ul>	Set color temperature
RED GAIN	128	0~256	Adjust the Red Gain
GREEN GAIN	128	0~256	Adjust the Green Gain
BLUE GAIN	128	0~256	Adjust the Blue Gain
RED BIAS	0	-127~127	Adjust the Red Offset
GREEN BIAS	0	-127~127	Adjust the Green Offset
BLUE BIAS	0	-127~127	Adjust the Blue Offset
COPY FROM	D65	<ul style="list-style-type: none"> <li>• D32: 3200K</li> <li>• D50: 5000K</li> <li>• D56: 5600K</li> </ul>	Copy this parameter value to USER

Items	Default Value	Domain Range	Description
		<ul style="list-style-type: none"> <li>D65: 6500K</li> <li>D93: 9300K</li> </ul>	
RESET	--	--	Reset the Gain and Offset values to the product originals
COLOR SPACE	EBU	OFF/EBU/SMPTE-C/ITU-709/AUTO	Select the color matrix

### Tips

- The items about RED/GREEN/BLUE GAIN and BIAS are available only in USER1 and USER2 mode. If the COLOR TEMP is set to **USER1** or **USER2** with customized settings, you can select the menu item **COLOR TEMP** → **RESET** command to restore product originals for Gains and Offsets, and press **ENTER** button to confirm the reset operation.

## 5.1.9 FUNCTION KEY Menu

The FUNCTION KEY menu items are used to define parameters to F1 and F2, the menu items are as shown in Figure 5.1-29:

MAIN	FUNCTION KEY
STATUS ▶	F1 SCAN
INPUT SELECT ▶	F2 OFF
MARKER ▶	
AUDIO ▶	
DISPALY ▶	
CLOSED CAPTION ▶	
CONFIG ▶	
COLOR TEMP ▶	
<b>FUNCTION KEY ▶</b>	
IMD ▶	

*Figure 5.1-29 FUNCTION KEY Menu*

The relationship of Items, Default Value, Domain Range and Description

of the sub-item is shown in Table 5.1-11:

**Table 5.1-11 The Description of FUNCTION KEY Menu Items**

Items	Default Value	Domain Range	Description
F1	SCAN	SCAN, NATIVE, ASPECT, BLUE ONLY, MONO, MARKER, H/V DELAY, AUDIO METER, FAST MODE, TC, IMD, MUTE, PBP, CC, FREEZE, WIN SELECT, FOCUS ASSIST, LUMA ZOOM CHECK, UNDEF	Set a function to F1 button
F2	SCAN	the same as F1	Set a function to F2 button

### 1. SCAN

This product supports the following scan modes:

NORMAL → OVER → UNDER

Set the function button as [SCAN], press the button continuously to activate various scan modes.

- OVER: Zooms in/out of the image to 96% of its original size without changing the aspect ratio.
- NORMAL: Zooms in/out of the image without changing the aspect ratio.
- UNDER: Zooms in/out of the image without changing the aspect ratio. Also, displays the data at the top of the horizontal blanking block.

2. ASPECT: Set the aspect ratio of the screen as 4:3 or 16:9.

### 3. FREEZE

Active this function to freeze the current frame displayed, press the function button again to release the freeze and continue to display.

### 4. BLUE ONLY

It is to activate BLUE ONLY mode that will remove red and green from the input signal and display the screen only under a blue signal.

### 5. MONO

It is to activate MONO mode that will display the screen in monochrome presentation, inactivate this mode to display the screen in color mode.

- Press F1, F2 button to activate the assigned function and adjust the parameter value.
- The **SCAN** mode or the ASPECT mode is not selectable when Native mode is set to ON.
- Particularly, when the **PBP** function is assigned to a function key, press this function key to select the display mode for picture & picture display.

### 5.1.10 IMD Menu

The IMD menu items are used to adjust the parameters defined for IMD display, the menu items are as shown in Figure 5.1-30:

MAIN		IMD	
STATUS	▶	IMD DISPLAY	ON
INPUT SELECT	▶	IMD COLOR	RED
MARKER	▶	IMD CHARACTER	XXXXXXXX
AUDIO	▶	IMD PROTOCOL	LOCAL
DISPALY	▶	IMD ID	000
CLOSED CAPTION	▶	IMD NAME	XXX
CONFIG	▶	BAUD RATE	38400
COLOR TEMP	▶	LED TALLY	OFF
FUNCTION KEY	▶	OSD TALLY MODE	RG
<b>IMD</b>	▶	IMD TALLY MODE	T1
		TALLY SOURCE	STANDARD

**Figure 5.1-30 IMD Menu**

The relationship of Items, Default Value, Domain Range and Description of the sub-item is shown in Table 5.1-12:

**Table 5.1-12 The Description of IMD Menu Items**

Items	Default Value	Domain Range	Description
IMD DISPLAY	ON	OFF/ON	Set whether to display IMD CHARACTER on screen.
IMD COLOR	RED	<ul style="list-style-type: none"> <li>• RED</li> <li>• GREEN</li> </ul>	Set the color for IMD CHARACTER.

Items	Default Value	Domain Range	Description
		<ul style="list-style-type: none"> <li>• YELLOW</li> <li>• WHITE</li> </ul>	
IMD CHARACTER	XXXXXXXX	--	Set the IMD string displayed on the screen. After entering this item, press Up or Down to choose your character for this IMD string.
IMD PROTOCOL	LOCAL	<ul style="list-style-type: none"> <li>• LOCAL</li> <li>• TSL3.1</li> <li>• TSL4.0</li> <li>• TSL5.0</li> <li>• IMAGE VIDEO</li> <li>• NETWORK</li> </ul>	Select an IMD protocol
IMD ID	000	0~255	Set the ID number for IMD
IMD NAME	XXXXXXXX		Set an IMD name for each screen.
BAUD RATE	38400	2400/4800/9600/19200 /38400/57600/115200	Select a baud rate for communication.
LED TALLY	ON	OFF/ON	Set whether to switch on tally light.
OSD TALLY MODE	RG	<ul style="list-style-type: none"> <li>• RG: Red/Green</li> <li>• GR: Green only</li> <li>• RGY: Red/Green/Yellow</li> <li>• OFF: No tally light</li> </ul>	Select the OSD Tally mode. Only the TALLY SOURCE is STANDARD, the setting is available.
IMD TALLY MODE	T1	T1/T2/T1T2/T2T1/T1-/T2-/T1T2-/T2T1-	Select the IMD Tally mode. Use this setting when using the Image Video tally control, this item will determine the IMD state as the selected value.
TALLY SOURCE	STANDARD	STANDARD/IMAGE IDEO/TSL	Select the source for OSD Tally source

### Tips

- The length of IMD NAME and IMD CHARACTER is up to 16 characters. The character range is from 0x00 to 0x7F of ASCII. Press **ENTER** to edit



the IMD characters, than use  $\wedge$ (Up) and  $\vee$ (Down) to select characters, than press **ENTER** to go to next character, press **MENU** to exit editor.

- When the IMD PROTOCOL is set to be **Local**, the IMD CHARACTER can only be modified through the control buttons( $\wedge$ (Up) and  $\vee$ (Down)), and the IMD CHARACTER could be composed of up to 16 characters. When the IMD PROTOCOL is set to be NETWORK, the IMD CHARACTER should be modified through the IMD page in the network control page, and the IMD CHARACTER could be composed of up to 16 characters or up to 12 Chinese characters. For other values of IMD PROTOCOL, the IMD CHARACTER abides by the corresponding protocol.

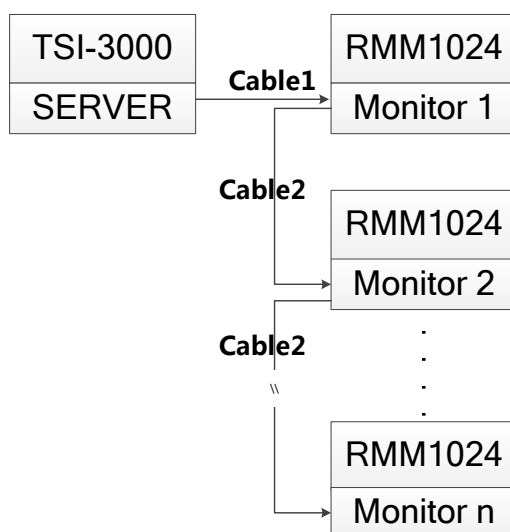
The PRM1014 monitor could receive the Tally control signal from a TSL server, and display the Tally information on PRM1014 through the LED tally and OSD tally. We support the TSI3000 and TSL TallyMan Controller as the TSL server, and it will be introduce how to connect with them, and how to set the IMD parameters for various IMD protocol.

### 5.1.10.1 Device Connection

Follow the instructions below to connect monitor with TSL server.

#### 1. TSI-3000--RMM1024

Connect the TSI-3000 with RMM1024, as shown in **Figure 5.1-31**:



**Figure 5.1-31 TSL Server and Display Monitor**

We recommend the following two methods according to the different interface of TSI-3000 which is selected to connect with RMM1024.

### METHOD1

#### Use the COM7~COM12 interface of TSI-3000 to connect with RMM1024

##### ■ Cable1

Use Cable1 to connect one of the COM7~COM12 interface at the rear panel of TSI-3000 with the RS485 Interface of RMM1024, the functionality of the interfaces are as shown in the following table.

##### □ RS485(RMM1024): RJ45

Use the RS485 interface to connect with TSI-3000, the RS485 uses the RJ45 connector, and the function of RS485 interface of RMM1024 is defined as in **Table 5.1-13**:

**Table 5.1-13 The Pins Input/output connectors for RS485 of RMM1024**

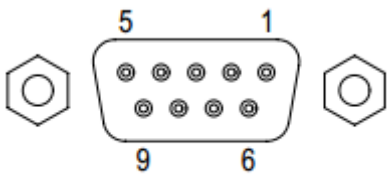
PIN No.	RS485 IN Terminal Signal	RS485 OUT Terminal Signal	Illustration
1,2	GND	GND	
3	Tx-	Tx-	
4	Rx+	Rx+	
5	Rx-	Rx-	
6	Tx+	Tx+	
7,8	NC	NC	

##### □ COM(TSI-3000): DB9

Use one of the **COM7~COM12** interface at the rear panel of TSI-3000 to connect with RMM1024 monitor, the **COM7~COM12** has the female DB9 connector, and the function of **COM7~COM12** interface of TSI-3000 is defined as in **Table 5.1-14**:

**Table 5.1-14 The Pins of COM\* in TSI-3000**

PIN No.	DB9	Illustration
1	GND	
2	Rx-(data from external device)	

PIN No.	DB9	Illustration
3	Tx+(data to external device)	 <p style="text-align: center;"><b>Female DE-9</b></p>
4	GND(Tx Data Common)	
5	NC	
6	GND(Rx Data Common)	
7	Rx+(data from external device)	
8	Tx-(data to external device)	
9	GND	

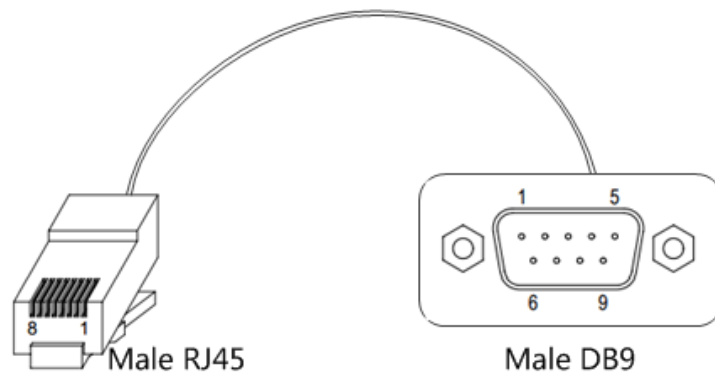
The connection should obey the rules below to set up the communication between one of **COM7~COM12** and RS485, as shown in **Table 5.1-15**:

**Table 5.1-15 Connection Between COM7~COM12 of TSI-3000 and RS485 of RMM1024**

DB9(COM7~COM12)	RJ45(RS485)
2	3
3	4
4	2
6	1
7	6
8	5

□ **Cable1**

The connectors at the two ends of **CABLE1** should be one male RJ45 connector and one Male DB9 connector, as shown in **Figure 5.1-32**:



**Figure 5.1-32 Cable1**

The pin sequence should be defined as in **Figure 5.1-33**:

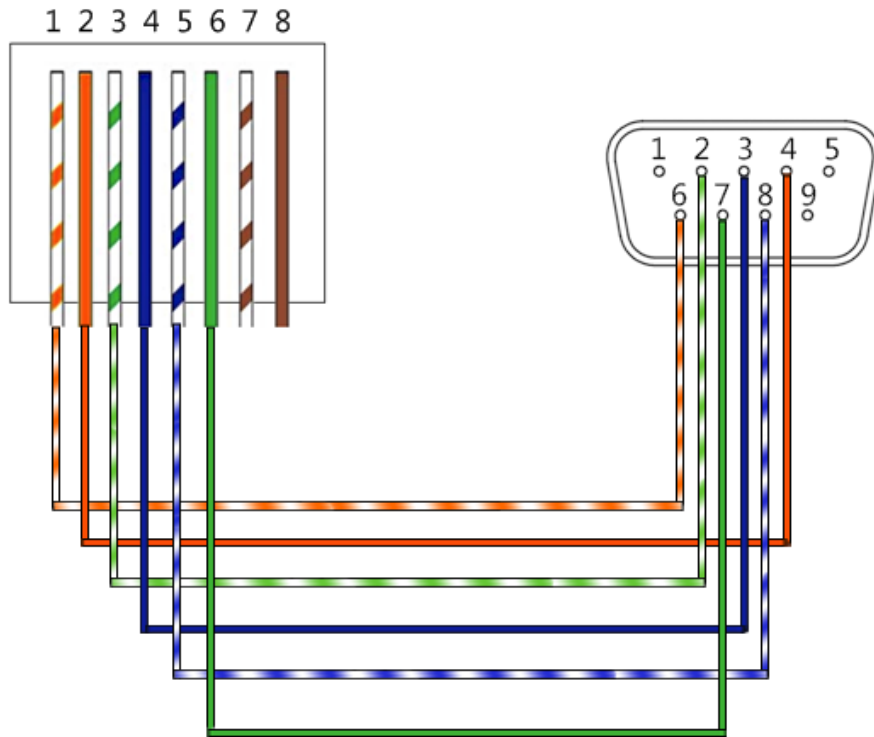


Figure 5.1-33 Pin Sequence of Cable1

## METHOD2

### Use the COM3~COM6 interface of TSI-3000 to connect with RMM1024

#### ■ Cable1

Use Cable1 to connect one of the COM3~COM6 interface at the rear panel of TSI-3000 with the RS485 Interface of RMM1024, the functionality of the interfaces are as shown in the following table.


#### □ RS485(RMM1024): RJ45

Use the RS485 interface to connect with TSI-3000, the RS485 uses the RJ45 connector, and the function of RS485 interface of RMM1024 is defined as in **Table 5.1-13**, please refer to the above **Table 5.1-13** for the details, no repeat here.

#### □ COM(TSI-3000): 6P6C

Use one of the **COM3~COM6** interface at the rear panel of TSI-3000 to connect with RMM1024 monitor, the **COM3~COM6** has the 6P6C connector, and the function of **COM3~COM6** interface of TSI-3000 is defined as in **Table 5.1-16**:

**Table 5.1-16 The Pins of COM\* in TSI-3000**

PIN No.	6P6C	Illustration
1	Rx-(data from external device)	
2	GND(Data Common)	
3	Tx+(data to external device)	
4	Tx-(data to external device)	
5	Not connected	
6	Rx+(data from external device)	

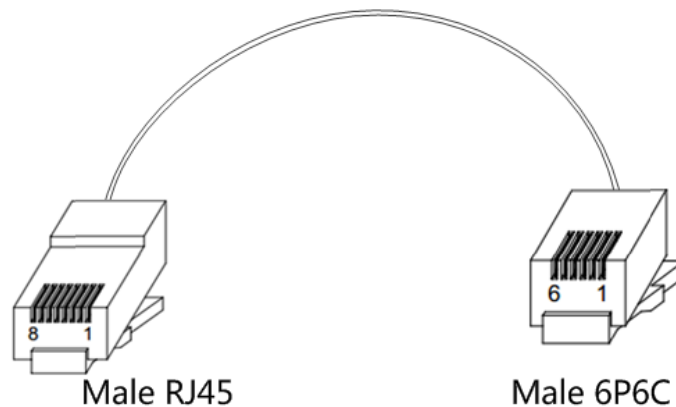
The connection should obey the rules below to set up the communication between one of **COM3~COM6** and RS485, as shown in **Table 5.1-17**:

**Table 5.1-17 Connection Between COM3~COM6 of TSI-3000 and RS485 of RMM1024**

6P6C(COM3~COM6)	RJ45(RS485)
1	3
3	4
2	2
5 (Not connected)	1(Not connected)
6	6
4	5

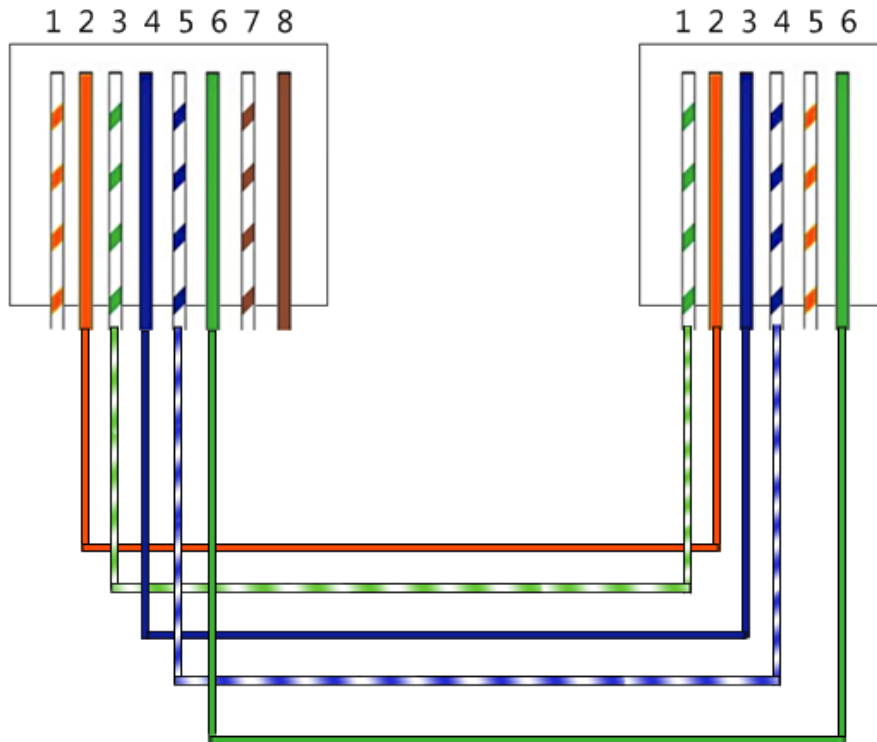
□ **Cable1**

The connectors at the two ends of **CABLE1** should be one male RJ45 connector and one Male 6P6C connector, as shown in **Figure 5.1-34**:



**Figure 5.1-34 Cable1**

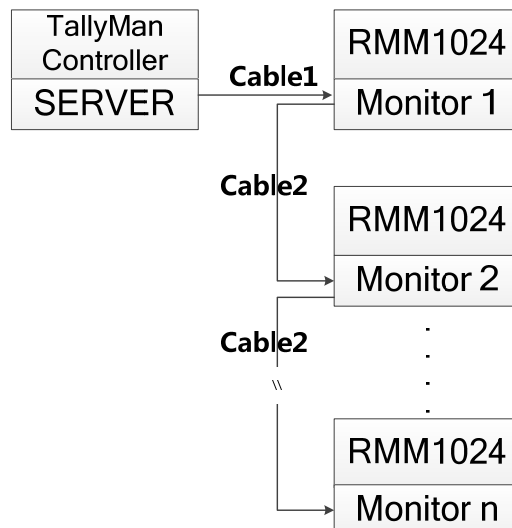
The pin sequence should be defined as in **Figure 5.1-35**:



**Figure 5.1-35 Pin Sequence of Cable1**

2. TallyMan--RMM1024

Connect the TallyMan Controller TM1/TM2/TM2 PLUS with RMM1024, as shown in **Figure 5.1-36**:



**Figure 5.1-36 TSL Server and Display Monitor**

■ Cable1

Use Cable1 to connect one of the CONTROL1/CONTROL2(RS422) interface at the rear panel of TallyMan Controller with the RS485 Interface of RMM1024, the functionality of the interfaces are as shown in the following table.

□ **RS485(RMM1024): RJ45**

The definition of RS485 interface of RMM1024 is as the same as in TSI-3000-RMM1024 system, please refer to the above **Table 5.1-13** for the details, no repeat here.

□ **RS422(TallyMan Controller): DB9**

Use one of the **CONTROL1/CONTROL2** interface at the rear panel of TallyMan Controller to connect with RMM1024 monitor, the **CONTROL1/CONTROL2** is a **RS422** interface using female DB9 connector, and the pins of DB9 is defined as in **Table 5.1-18**:

**Table 5.1-18 The Pins of CONTROL1/CONTROL2 in TallyMan Controller**

PIN No.	DB9	Illustration
1	0v/Chassis	
2	Tx-	
3	Rx+	
4	0v	
5	-	
6	0v	
7	Tx+	
8	Rx-	
9	0v	

The connection should obey the rules below to set up the communication between one of **CONTROL1/CONTROL2** and RS485, as shown in **Table 5.1-19**:

**Table 5.1-19 Connection Between CONTROL1/CONTROL2 of TallyMan Controller and RS485 of RMM1024**

DB9(CONTROL1/CONTROL2)	RJ45(RS485)
2	5
3	6

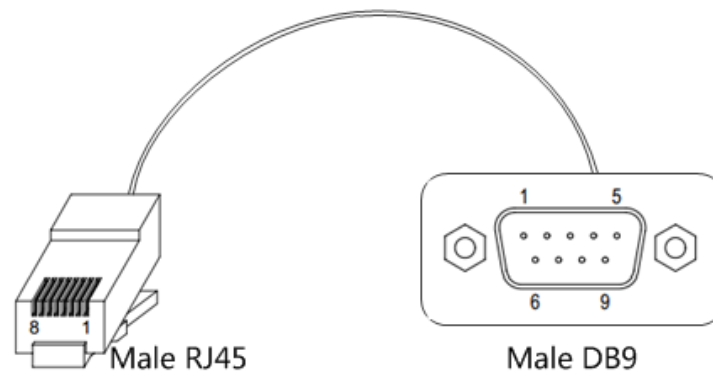
DB9(CONTROL1/CONTROL2)	RJ45(RS485)
4	2
6	1
7	4
8	3

**i Tips**

- TSL TallyMan Controller TM1, TSL TallyMan Controller TM2, TSL TallyMan Controller TM2 PLUS all conform to the above definition about the connection and the pins relationship. Refer to the user manuals of these devices for details.

□ **Cable1**

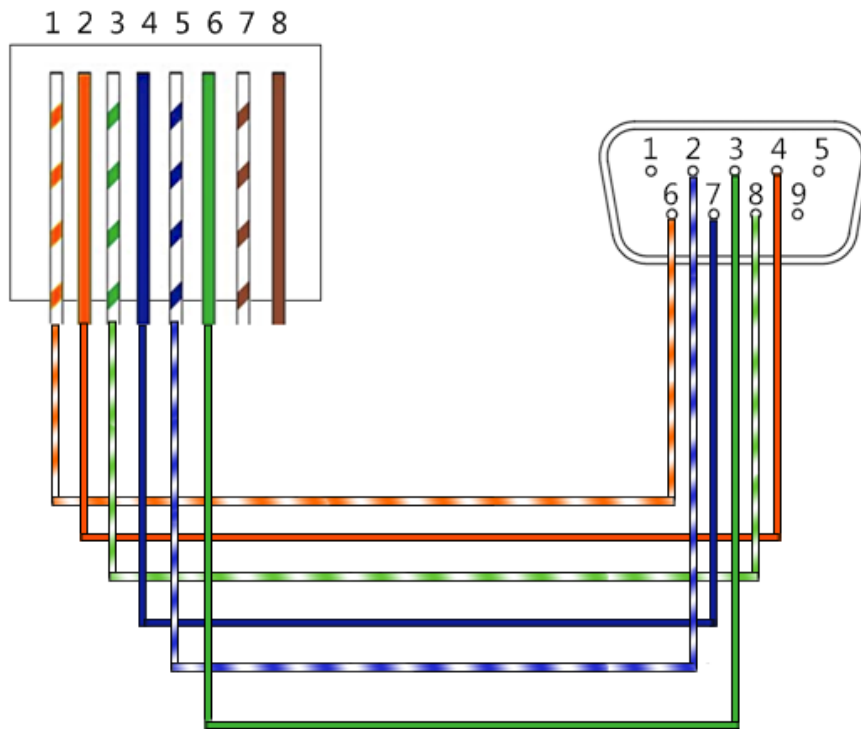
The connectors at the two ends of **CABLE1** should be one male RJ45 connector and one Male DB9 connector, as shown in **Figure 5.1-37**:



**Figure 5.1-37 Cable1**

The pin sequence should be defined as in **Figure 5.1-38**:

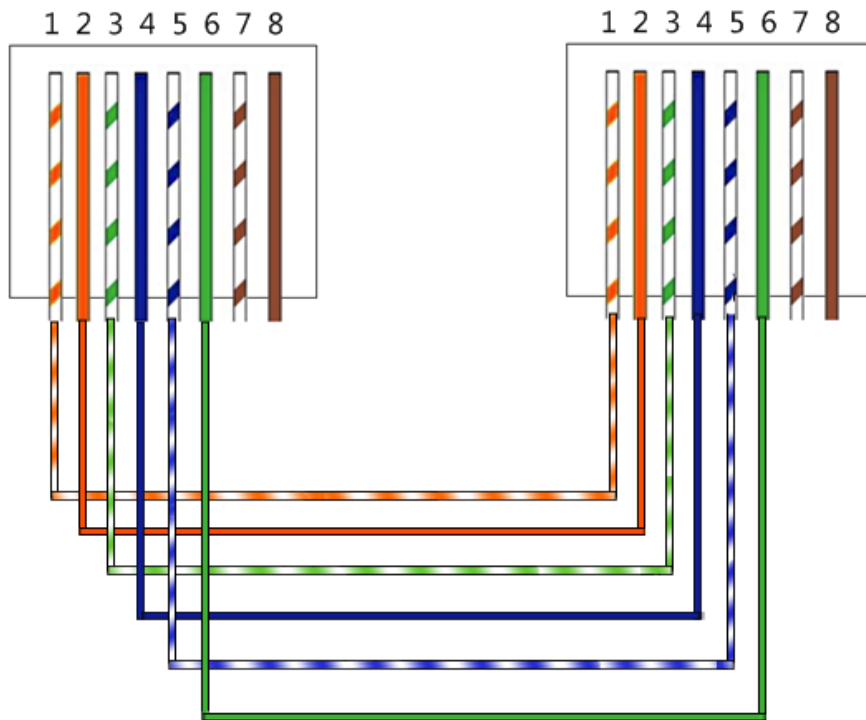




**Figure 5.1-38 Pin Sequence of Cable1**

■ **Cable2**

Use **Cable2** to connect every two RMM1024 monitors through the RS485 Interface, the **Cable2** is a straight through line, and the connectors at the two ends of **Cable2** should both be male RJ45. The pin sequence of **Cable2** should be defined as in **Figure 5.1-39**:



**Figure 5.1-39 Pin Sequence of Cable2**

### 5.1.10.2 IMD Settings

The position of Tally display on the PRM1014 monitor is as shown in **Figure 5.1-40**. The **LED Tally** indicator is displayed at the top center of the monitor, and the two **OSD Tally** lights are displayed at the bottom of the monitor screen, separately at the left and right side of the **IMD** characters.

The tally lights will be in various color when selecting different values for the **IMD Protocol** item. It will introduce one by one in the below.

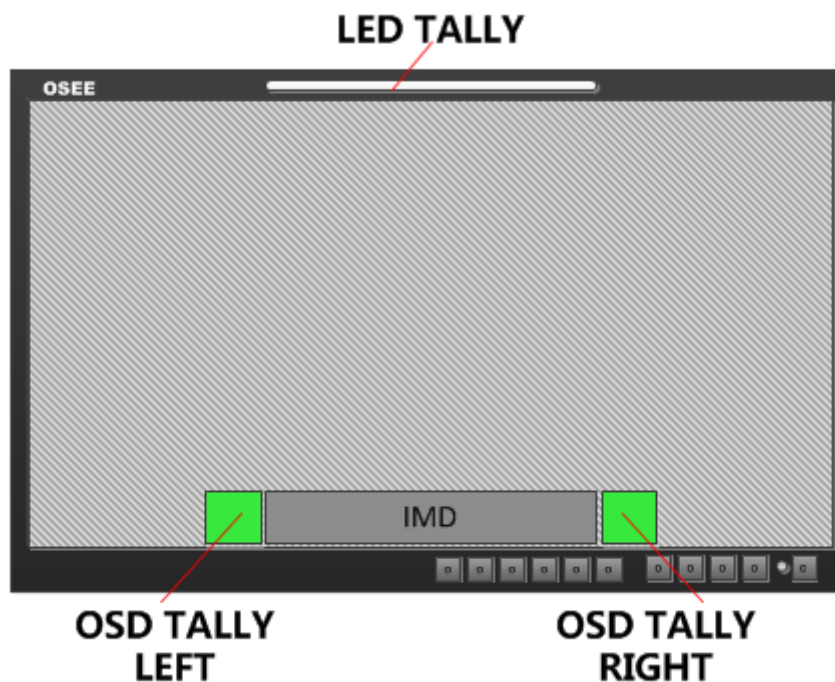


Figure 5.1-40 Tally Display

## Tips

- When receiving data of TSL3.1 or TSL4.0 protocol, we support the data length to be 0~126 and 128~254. When the data is in 128~254, the result will be equal to subtract 128 from the IMD ID, in addition, the data length is 0~255 when receiving data of MAGE VIDEO protocol.

### 1. TSL3.1

Set **IMD→IMD Protocol** item to be TSL3.1, the monitor could receive the tally control command from a TSL Tally controller or other control devices conforming to TSL3.1 protocol.

#### ■ Physical characteristic

Com Port:	RS232/RS422/RS485
DataBits:	8
StopBits:	1
Parity:	Even
Baud Rate:	38400

■ IMD Items

Items	Value	Description
IMD DISPLAY	ON	
IMD PROTOCOL	TSL3.1	it could receive the data of TSL4.0 protocol
IMD ID	0	
BAUD RATE	38400	
LED TALLY	ON	It will display as the result of OR relationship of LEFT OSD Tally and RIGHT OSD Tally. When only one of the two lights is lit, the LED Tally will light in the same color as the lit OSD Tally's, otherwise, when the two lights of OSD Tally are lit, the LED Tally will light in yellow. (This rule is not fit for LED Tally when the OSD TALLY MODE item is set to be GR.)
OSD TALLY MODE	RG	
	GR	
	RGY	
	OFF	Close the OSD TALLY
TALLY SOURCE	TSL	

**2. TSL4.0**

Set **IMD→IMD Protocol** item to be TSL4.0, the monitor could receive the tally control command from a TSL Tally controller or other control devices conforming to TSL4.0 protocol.

■ Physical characteristic

Com Port:	RS232/RS422/RS485
DataBits:	8
StopBits:	1
Parity:	Even
Baud Rate:	38400

■ IMD Items

Items	Value	Description
IMD DISPLAY	ON	
IMD PROTOCOL	TSL4.0	
IMD ID	0	
BAUD RATE	38400	
LED TALLY	ON	It will display as the result of OR relationship of LEFT OSD Tally and RIGHT OSD Tally. When only one of the two lights is lit, the LED Tally will light in the same color as the lit OSD Tally's, otherwise, when the two lights of OSD Tally are lit, the LED Tally will light in yellow. (This rule is not fit for LED Tally when the OSD TALLY MODE item is set to be GR.)
OSD TALLY MODE	RG/GR/RGY	Select anyone of these three items to open the OSD TALLY, the color and the status of the LEFT OSD TALLY and RIGHT OSD TALLY will conform to the receiving instructions of the corresponding TSL protocol.
	OFF	Close the OSD TALLY
TALLY SOURCE	TSL	

### 3. Image Video

Set **IMD**→**IMD Protocol** item to be IMAGE VIDEO, the monitor could receive the tally control command from an IMAGE VIDEO controller or other control devices conforming to IMAGE VIDEO protocol.

#### ■ Physical characteristic

Com Port:	RS232/RS485
DataBits:	7
StopBits:	2
Parity:	Even
Baud Rate:	38400

#### ■ IMD Items

Items	Value	Description
IMD DISPLAY	ON	
IMD PROTOCOL	IMAGE VIDEO	
IMD ID	0	

Items	Value	Description
BAUD RATE	38400	
LED TALLY	ON	It will display as the result of OR relationship of LEFT OSD Tally and RIGHT OSD Tally. When only one of the two lights is lit, the LED Tally will light in the same color as the lit OSD Tally's, otherwise, when the two lights of OSD Tally are lit, the LED Tally will light in yellow. (This rule is not fit for LED Tally when the OSD TALLY MODE item is set to be GR.)
OSD TALLY MODE	RG/GR/RGY	Select anyone of these three items to open the OSD TALLY, the color and the status of the LEFT OSD TALLY and RIGHT OSD TALLY will comfort to the receiving instructions of the IMAGE VIDEO protocol.
	OFF	Close the OSD TALLY
IMD TALLY MODE	T1	T1/T2/T1T2/T2T1/T1-/T2-/T1T2-/T2T1-(Comfort to the receiving instructions of the IMAGE VIDEO protocol, refer to IMAGE VIDEO protocol for details)
TALLY SOURCE	IMAGE VIDEO	

The monitor supports the following command set in IMAGE VIDEO 1510 protocol: D(d), S(s), C(c), J(j), O(o), U(u), Z(z). And the following command set are not supported currently: F(f), T(t), A(a), 1Y(y), I(i), 1L(l), V(v), Q(q), N(n),X(x).

We has only one IMD information on the screen, so in S(s) command, the line number for the UMD text can just be 1, for example, the command should be:

%0D%1Sone line%z.

#### 4. TSL5.0

Set **IMD→IMD Protocol** item to be TSL5.0, the monitor could receive the tally control command from network devices conforming to UDP protocol.

- Physical characteristic

Use RJ45 interface in UDP protocol, the maximum length of data package is 2048 Bytes, and the port number is 5000.

## 5.2 Menu Settings

When checking or modifying the value of the menu item, cooperating with the following buttons: MENU, ^(Up), v(Down), ENTER.

### 1. Operations to the Main menu

■ **Display the Main Menu**

Press **MENU** button to enter into the main menu, it displays at the top left corner of the screen.

■ **Switch menu items**

After displaying the main menu, press **^ (Up)** or **∨ (Down)** button to choose a menu item, the menu item selected is in yellow. For example, you have selected **Status** menu, as shown in Figure 5.2-1.

MAIN	STATUS	
STATUS	▶ INPUT	SDI1
INPUT SELECT	▶ FORMAT	NO SIGNAL
MARKER	▶ COLOR TEMP	D65
AUDIO	▶ SCAN MODE	OVER
DISPALY	▶ FAST MODE	OFF
CLOSED CAPTION	▶ MODEL	PRM1014-3HSV
CONFIG	▶ SERIAL NUMBER	PRM10142015010001
COLOR TEMP	▶ IP ADDRESS	192.168.1.86
FUNCTION KEY	▶ COLOR VERSION	2015 -1 -5.4
IMD	▶	

*Figure 5.2-1 Selecting STATUS Menu*

■ **Back to the Main menu**

After entering to a sub-menu item or a sub-menu item value, press **MENU** button to back to the upper level menu area.

■ **Close the Main menu**

Press **MENU** button to close the Main menu when the control icon is in the Main menu item.

**Tips**

- After you have loaded the Main menu, it will be closed automatically if you do nothing operation with it in 60s.

**2. Operations to sub-menu item**

■ **Display the sub-menu item**

After display the Main menu, press **^ (Up)** or **∨ (Down)** button to select a menu item, and the right part displays its sub-menu items

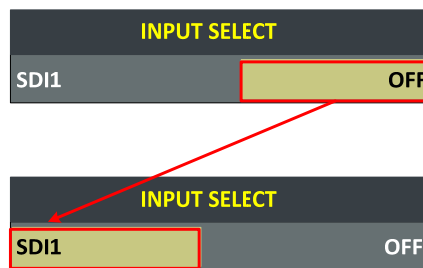
according to the current selected menu item.

■ **Switch sub-menu items**

After displaying the sub-menu items list, press **ENTER** button to enter into the sub-menu items list, press **^ (Up)** or **∨ (Down)** button to choose a sub-menu item, a yellow rectangle is in front of the selected sub-menu item.

■ **Back to menu item**

After entering to the sub-menu item value, press **MENU** button to back to menu items, or after setting the sub-menu item value and press **Enter** button to firm the modification, the control icon is back to the corresponding sub-menu item, as shown in Figure 5.2-2:



**Figure 5.2-2** *The Control Icon Moves from the Sub-menu Item Value to the Corresponding Sub-menu Item*

**3. Operations to sub-menu item value**

■ **Switch sub-menu item value**

When the control icon is in sub-menu item value, press **^ (Up)** or **∨ (Down)** button to switch among its value list.

■ **Confirm the modification to sub-menu item value**

Press **ENTER** button to confirm the selection of a value, and the control icon is back to the corresponding sub-menu item.

■ **Abandon the modification to sub-menu item value**

Press **MENU** button to give up the modification to sub-menu item value, and the control icon is back to the corresponding sub-menu item.

**i Tips**

- The value in white color is modifiable, and the value in blue color is unmodifiable.

**4. Selecting the Menu Language**



You can select one of languages (English or Chinese) for displaying the menu. The default language for the menu is ENGLISH. The following will teach you how to switch to Chinese.

■ Operation:

**Step 1 Select CONFIG menu**

Press **MENU** button to display the OSD menu, click √(down) button to select **CONFIG** menu.

**Step 2 Select the value of the Language item**

Press **ENTER** button to get into the **CONFIG** menu items, and click √(down) button to select the sub-item **LANGUAGE**, then, click **ENTER** button to get into the sub-value list, as shown in Figure 5.2-3, the current control icon is in **ENGLISH**.

MAIN		CONFIG	
STATUS	▶	FAST MODE	OFF
INPUT SELECT	▶	FILM MODE DETECT	OFF
MARKER	▶	SUB IN TYPE	PBP
AUDIO	▶	SUB IN SELECT	SD11
DISPALY	▶	PIP SIZE	LARGE
CLOSED CAPTION	▶	PIP POSITION	HORIZONTAL
<b>CONFIG</b>	▶	BACKLIGHT	15
COLOR TEMP	▶	AUTO STANDBY	OFF
FUNCTION KEY	▶	APPEATURE	0
IMD	▶	LOCK NUMBER	0
		LANGUAGE	<b>ENGLISH</b>

*Figure 5.2-3 Select the Value of Language*

**Step 3 Confirm the modification of the value of sub-item**

Click √(down) button to select the sub-item **LANGUAGE** to **Chinese**, as shown in Figure 5.2-4, press **ENTER** button to confirm the modification.

主菜单	系统配置	
状态显示	▶ 快速模式	关闭
输入设置	▶ 电影模式检测	关闭
标记设置	▶ 子画面类型	PBP
音频设置	▶ 子画面输入源	SDI1
显示设置	▶ PIP大小	小
隐藏字幕	▶ PIP位置	右下
系统配置	▶ 背光	15
色彩配置	▶ 自动关机	关闭
功能键设置	▶ 清晰度	0
IMD设置	▶ 授权码	0
	▶ 语言	中文

**Figure 5.2-4 Switching the Value of LANGUAGE**

**Step 4 Exit the main menu**

Click MENU button to exit the main menu.

## Chapter 6 Network Control

PRM1014 supports network interface. Connect a computer with PRM1014 through this interface to achieve the network control to PRM1014.

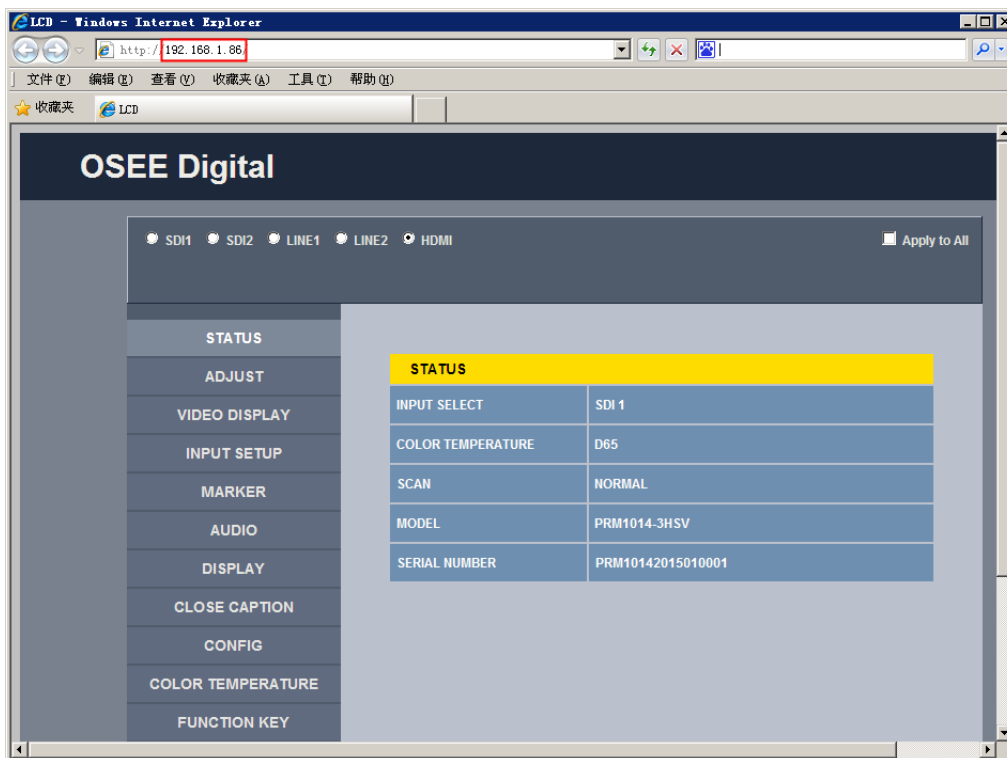
### Tips

- The network address of the computer which is connected with PRM1014 and the network address of PRM1014 must be in the same segment.

This chapter will introduce how to set and check the parameters of PRM1014 in Internet Explorer.

### 6.1 Access the settings

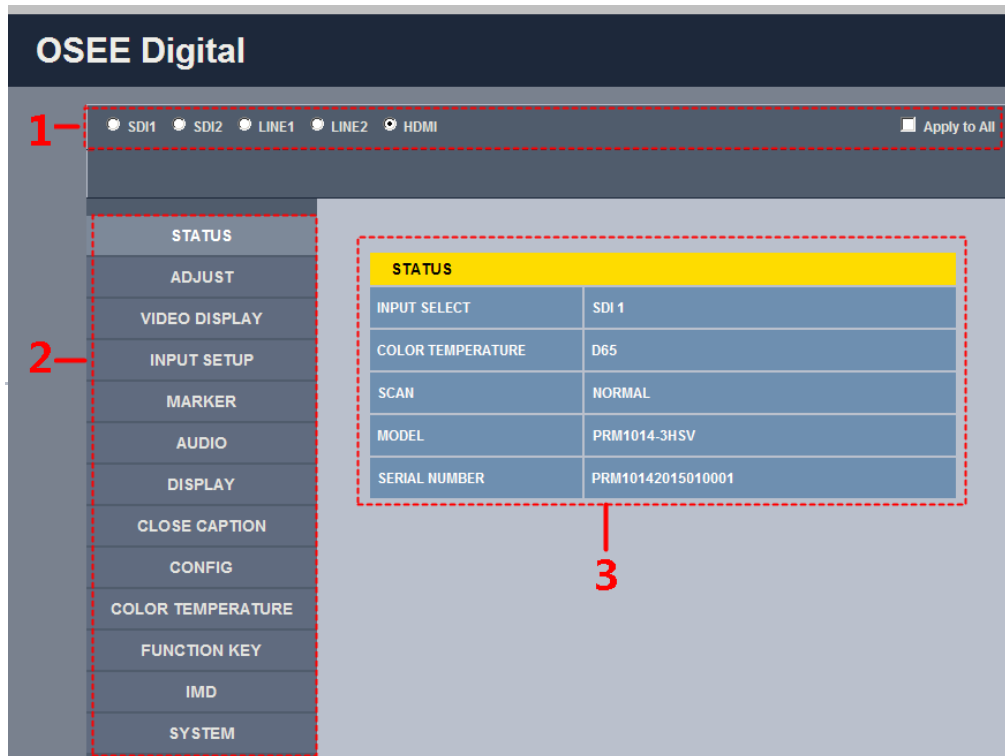
Use Internet Explorer to enter into a web control page. For example, input <http://192.168.1.86> in address bar, it will display the then, press Enter key, the management interface of PRM1014 is shown as in Figure 6.1-1:



**Figure 6.1-1 Network Control Page**

## 6.2 Menu Control

Open the management interface as shown in Figure 6.2-1, the menu items listed in the left part are almost as the same as the main menu items.



**Figure 6.2-1 Management Interface**

As shown in Figure 6.2-1, the management interface is divided into the following parts:

### 1. Input Source Selection Button

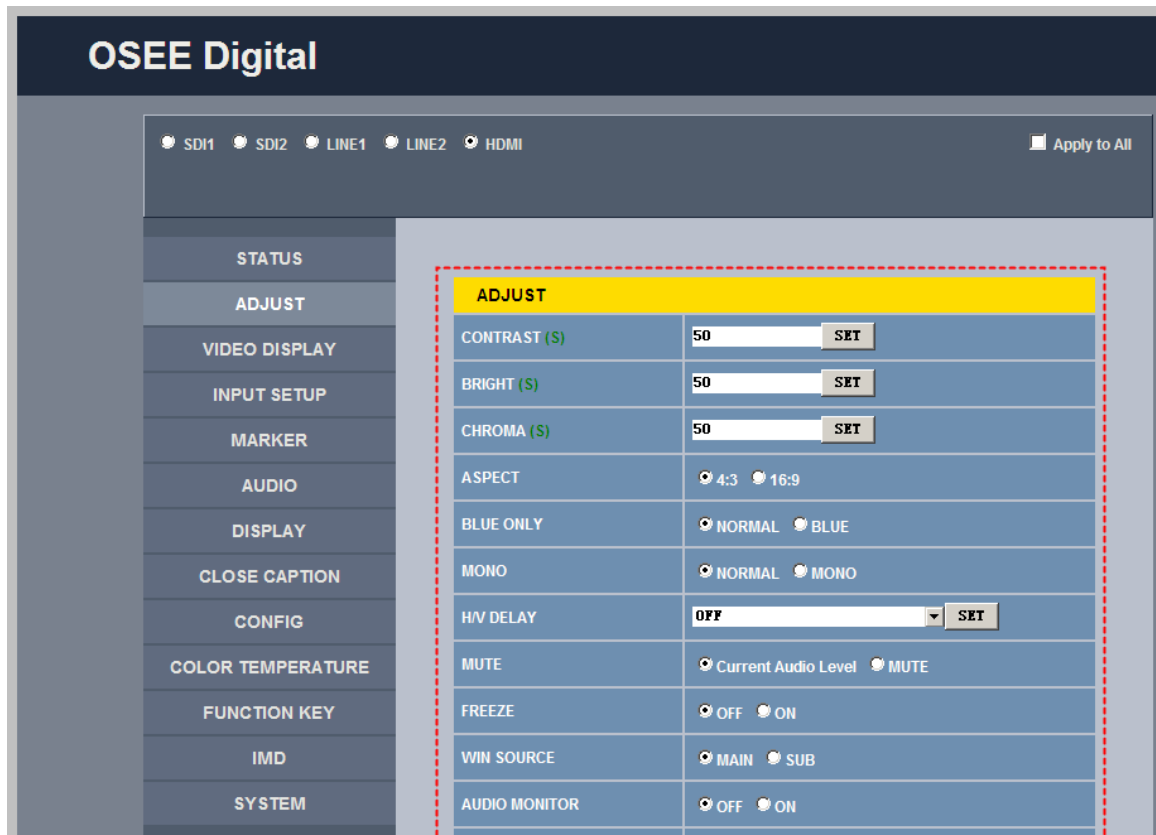
It is used to selecting an input source as the input signal, such as: SDI1, SDI2, LINE1, LINE2, HDMI. The selecting box of "Apply to All" at the right side is used to synchronize the settings of a signal source to another signal source.

### 2. Navigation menu list

It shows the navigation menus: **STATUS**, **ADJUST**, **VIDEO DISPLAY**, **INPUT SETUP**, **MARKER**, **AUDIO**, **DISPLAY**, **CLOSE CAPTION**, **USER CONFIG**, **COLOR TEMPERATURE**, **FUNCTION KEY**, **IMD** and **SYSTEM**. Click the navigation menu, it will show the corresponding settings on the right side. The menu items in main menu on screen display are mostly as the same as the menu items listed in navigation menus except **SYSTEM**.

### 3. Parameter list

It shows the parameter names, values and operation buttons of the selected navigation menu, as shown in the red rectangle in Figure 6.2-2. The title in the yellow rectangle of the parameter list and the parameter list will change with the navigation menu when switched.



**Figure 6.2-2 Parameter List**

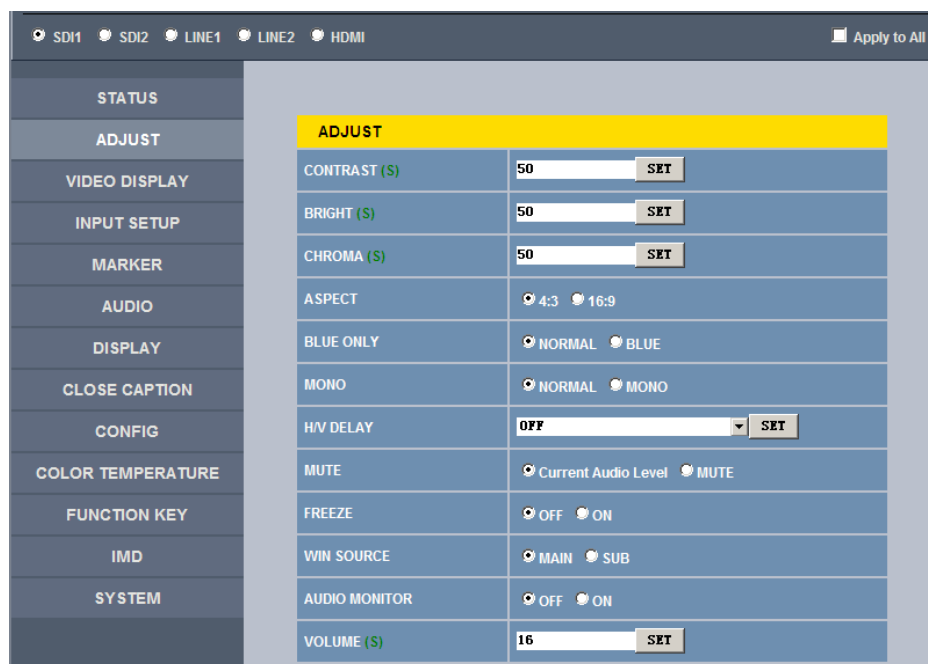
### Tips

- There may be a “(S)” icon followed by some parameter name in the parameter list, it means that this parameter is only a local parameter for the current selected monitor, otherwise, the parameter is global and the modification is valid for both screens.
- The SET button is used to confirm the modification of the parameter value.

## 6.2.1 ADJUST Menu

It will introduce **ADJUST** menu.

Click **ADJUST** button at the left navigation menu list, it will display the adjust parameters, as shown in Figure 6.2-3:



**Figure 6.2-3 ADJUST Menu**

The relationship of Items, Default Value, Domain Range and Description of the sub-item is shown in Table 6.2-1:

**Table 6.2-1 The Description of ADJUST Menu Items**

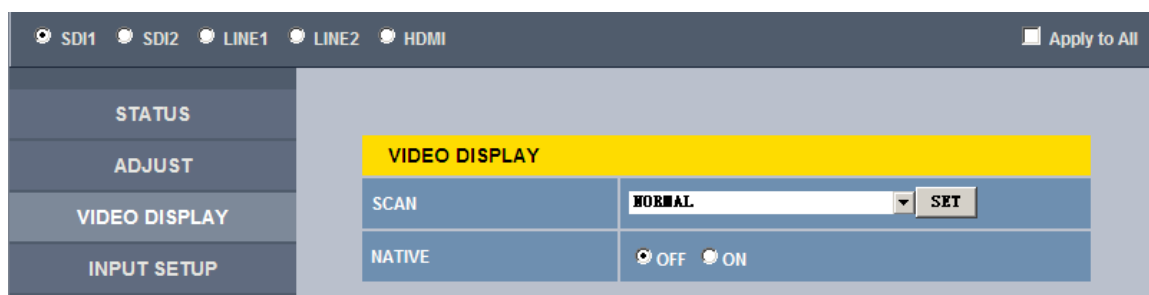
Items	Default Value	Domain Range	Description
CONTRAST	50	0~100	Adjust the picture contrast
BRIGHTNESS	50	0~100	Adjust the picture brightness
CHROMA	50	0~100	Adjust the picture monochroma
ASPECT	16:9	4:3/16:9	Set the aspect ratio of the picture
BLUE ONLY	NORMAL	NORMAL/BLUE	Enable/disable Blue Only mode
MONO	NORMAL	NORMAL/MONO	Enable/disable Monochrome mode,

Items	Default Value	Domain Range	Description
			normal mode is actually the color mode
H/V DELAY	OFF	OFF H DELAY V DELAY H/V DELAY	Display synchronizing signals in horizontal or vertical mode
MUTE	Current Audio Level	Current Audio Level MUTE	Enable/disable the audio monitor
FREEZE	OFF	OFF/ON	Enable/disable the current picture to be stopped or played.
WIN SOURCE	MAIN	MAIN/SUB	Set the picture displaying mode in full mode or in sub-picture mode
AUDIO MONITOR	OFF	OFF/ON	Set whether in audio monitoring.
VOLUME	16	0~31	Adjust the volume

## 6.2.2 VIDEO DISPLAY Menu

It will introduce **VIDEO DISPLAY** menu.

Click **VIDEO DISPLAY** button at the left navigation menu list, it will display the video display parameters, as shown in Figure 6.2-4:



**Figure 6.2-4 VIDEO DISPLAY Menu**

The relationship of Items, Default Value, Domain Range and Description of the sub-item is shown in Table 6.2-2:

**Table 6.2-2 The Description of VIDEO DISPLAY Menu Items**

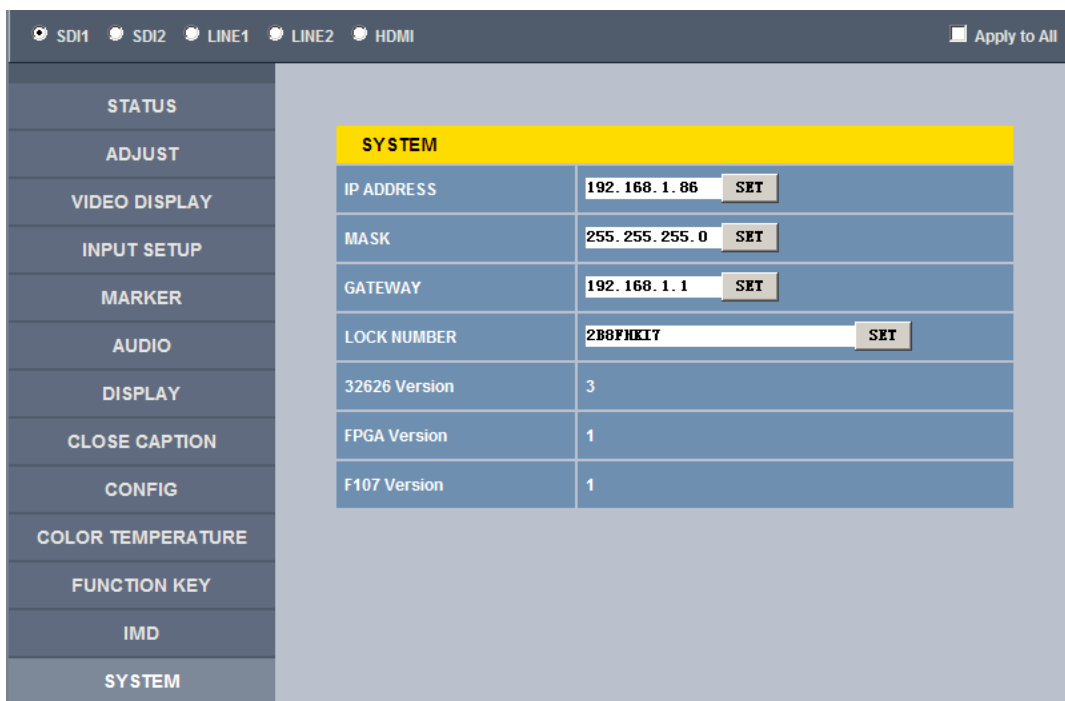
Items	Default Value	Domain Range	Description
-------	---------------	--------------	-------------

SCAN	NORMAL	<ul style="list-style-type: none"> <li>• NORMAL</li> <li>• OVERSCAN</li> <li>• UNDERSCAN</li> </ul>	Set the scan mode
NATIVE	OFF	OFF/ON	Whether to display the picture dot by dot

### 6.2.3 SYSTEM Menu

It will introduce **SYSTEM** menu.

Click **SYSTEM** button at the left navigation menu list, it will display the system parameters, as shown in Figure 6.2-5:



**Figure 6.2-5 System Menu**

The relationship of Items, Default Value, Domain Range and Description of the sub-item is shown in Table 6.2-3:

**Table 6.2-3 The Description of System Menu Items**

Items	Default Value	Domain Range	Description
IP	192.168.1.86	-	IP address
MASK	255.255.255.0	-	Subnet mask
Gateway	192.168.1.1	-	Gateway address



Items	Default Value	Domain Range	Description
LOCK NUMBER	0001	-	Serial Number
32626 Version	3	-	Product information
FPGA Version	1	-	Product information
F107 Version	1	-	Product information

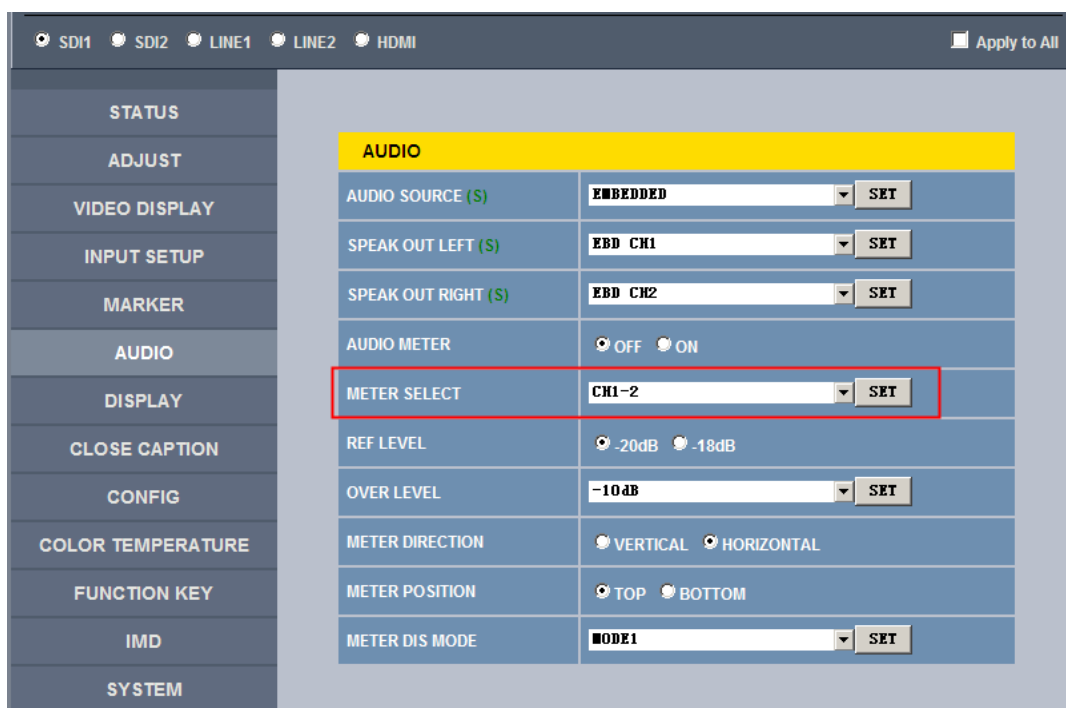
## 6.2.4 Other Menus

For the menu items in management interface are almost as the same as the menu items in the Main menu on screen, there will be no further description about their meanings and value range in this chapter, refer to “Chapter 5 Functionality of the Main Menu” for the details about **STATUS**, **VIDEO CONFIG**, **AUDIO CONFIG**, **MARKER**, **DISPLAY**, **USER CONFIG**, and **COLOR TEMPERATURE**.

## 6.3 Parameter Settings

It will introduce how to modify parameter values in management interface in the followings.

For example: modify **Meter Select** in **AUDIO** menu. Click **AUDIO** button to display its parameter list, as shown in Figure 6.3-1, the corresponding screen main menu is shown as in Figure 6.3-2:

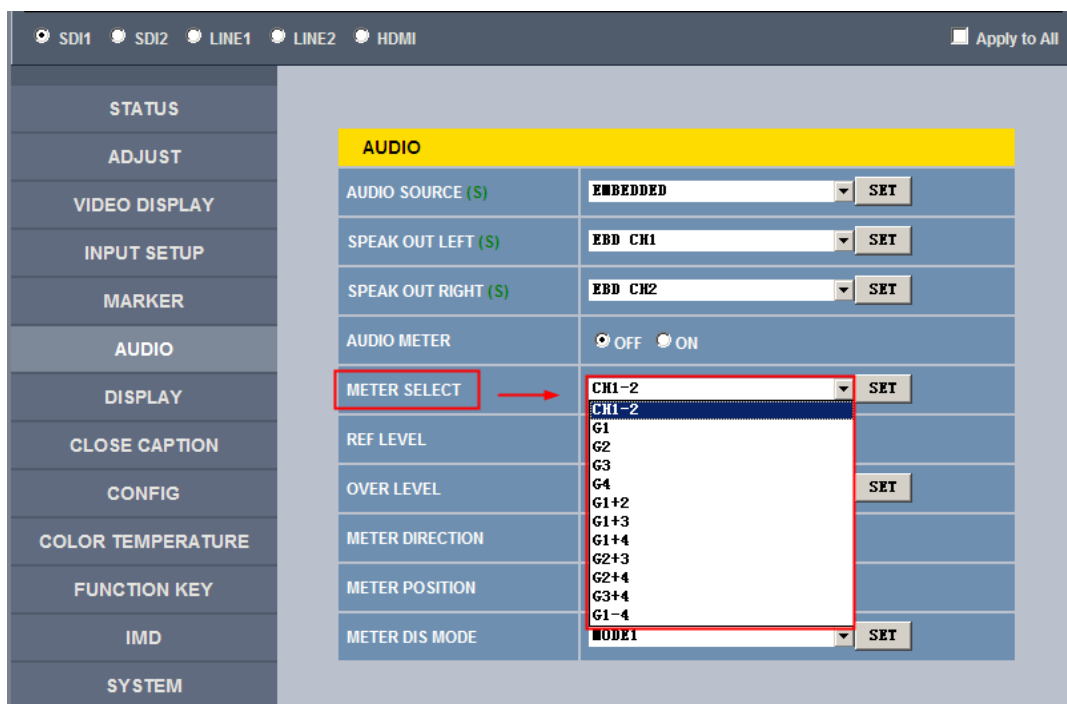


**Figure 6.3-1 Parameter List for AUDIO**

MAIN		AUDIO	
STATUS	▶	AUDIO SOURCE	AUDIO1
INPUT SELECT	▶	SPEAK OUT L	EBD CH1
MARKER	▶	SPEAK OUT R	EBD CH1
<b>AUDIO</b>	▶	AUDIO METER	OFF
DISPALY	▶	<b>METER SELECT</b>	CH1-2
CLOSED CAPTION	▶	METER DIRECTION	HORIZONTAL
CONFIG	▶	METER POSITION	TOP
COLOR TEMP	▶	METER DIS MODE	MODE1
FUNCTION KEY	▶	REF LEVEL	-20dB
IMD	▶	OVER LEVEL	-10dB

**Figure 6.3-2 Screen Main Menu for AUDIO**

Click button to display the drop-down value list for the parameter, as shown in Figure 6.3-3, for example, modify “CH1-2” to “G1”.



**Figure 6.3-3 Display the Drop Down Value List of Meter Select(S)**

Click button to confirm the selection and the page is refreshed. You can check the modification on the screen menu, the results are the same as shown in Figure 6.3-4 and Figure 6.3-5:

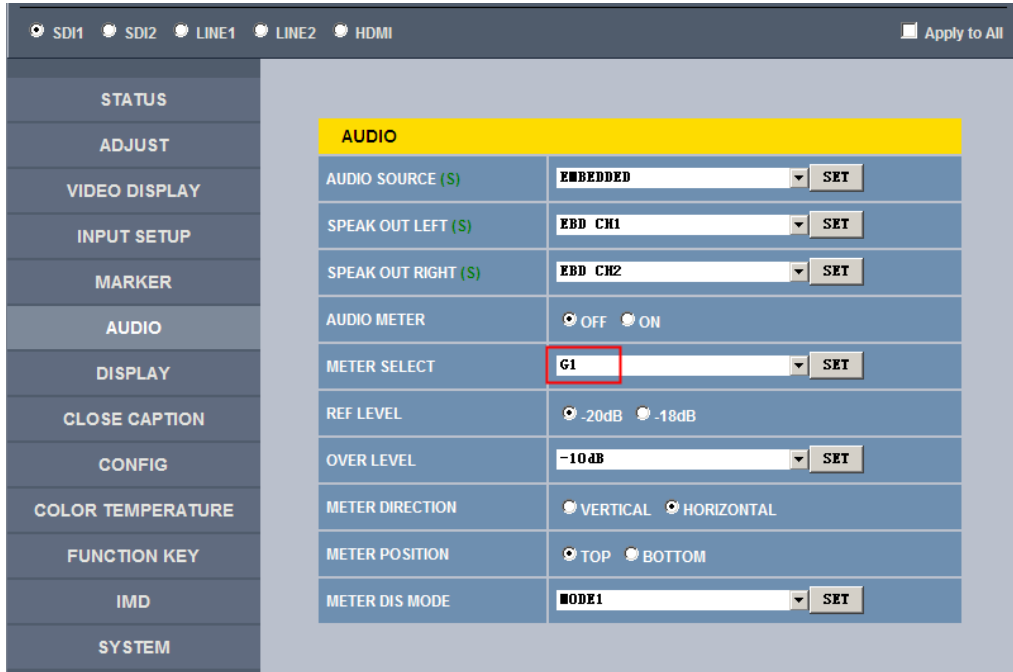


Figure 6.3-4 Modify the Value of a Parameter

**i Tips**

- The volume can be checked and modified in adjust menu on screen adjustment, or in **Volume** item of **ADJUST** menu in management interface.

MAIN	AUDIO
STATUS	AUDIO SOURCE AUDIO1
INPUT SELECT	SPEAK OUT L EBD CH1
MARKER	SPEAK OUT R EBD CH1
AUDIO	AUDIO METER OFF
DISPALY	METER SELECT G1
CLOSED CAPTION	METER DIRECTION HORIZONTAL
CONFIG	METER POSITION TOP
COLOR TEMP	METER DIS MODE MODE1
FUNCTION KEY	REF LEVEL -20dB
IMD	OVER LEVEL -10dB

Figure 6.3-5 The Value is Modified Simultaneously on Screen Menu

Likewise, if you modify the value of a parameter on screen menu first, you may check the same changing result in management interface through network connection.

032222

## Chapter 7 Specifications

### 1. Product detailed information

Specification	Values
Number of Screens	1
Aspect Ratio	16:10
Display Area(mm)	216.81(H)×135.50(V)
Viewing Angle	178° (H)x178° (V)
Color Depth	16.7M colors (RGB 8-bits)
Resolution	1920(H)×1200(V)
Dot Pitch(mm)	0.113(H)×0.113(V)
Contrast	800:1
Brightness(cd/m <sup>2</sup> )	400 typ. (5 points average) 340 min. (5 points average)
Response Time (ms Typ.)	<25
Backlight	WhiteLED
Backlight Life(Hrs)	20000
Work Temperature	0° C~35° C
Signal Formats	SD: 480i/59.94, 576i/50
	HD: SMPTE-274M: 1080i 50/59.94, 1080p/PsF 23.98/24/25
	HD: SMPTE-296M: 720p 50/59.94
	3G: SMPTE-425 level A(mapping 1): 1080p 50/59.94
	HDMI 1.3a
	Compliant to EIA/CEA-861-D
Input	3G/HD/SD-SDI Input(75Ohm BNCx2)
	Analog Composite (75Ohm BNCx2)
	HDMI Input(HDMI Type A)
	Analog stereo input(RCAx4)
Output	3G/HD/SD-SDI Input(BNCx2)
	Analog stereo output (RCAx2)

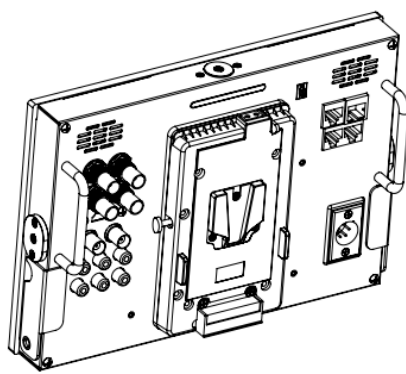
Specification	Values
	Stereo HEADPHONE (3.5mm stereo Jack)

## 2. Optional Accessories

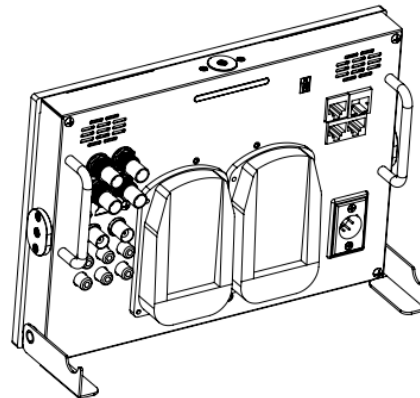
You can select the following accessories for PRM1014 optionally:

Type	Model	Description	Amount/per
Battery Plate	PRM1014-A-BM-V	V-mount battery plate	1
	PRM1014-A-BM-AB	AB-mount battery plate	1
	PRM1014-BP-970	SONY F-970 battery plate	1/2
	PRM1014-BP-D54S	Panasonic D54S Battery Plate	1/2
	PRM1014-BP-E6	Canon LP-E6 Battery Plate	1/2
Hanger	PRM-HS	Hot shoe mount	1
Hanger	PRM-MH	Magic arm	1
Monitor bag	PRM-PP	Monitor bag	1
Sun shade	PRM-SHD	Sun shade	1

If you want to use a battery as your backup power supply, you can choose the battery plate listed in the optional accessories table above, and you can select two types of battery plate according to your needs: one battery plate or two battery plates, as shown in the following figure:



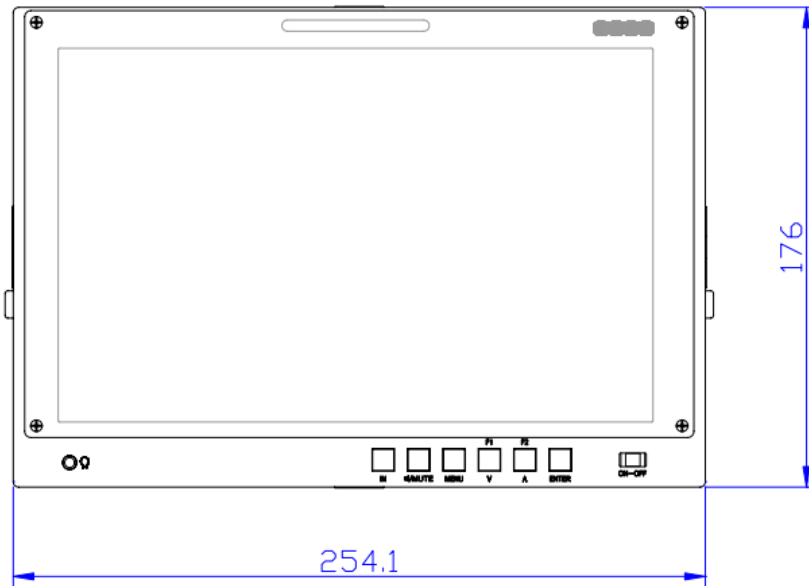
one battery plate



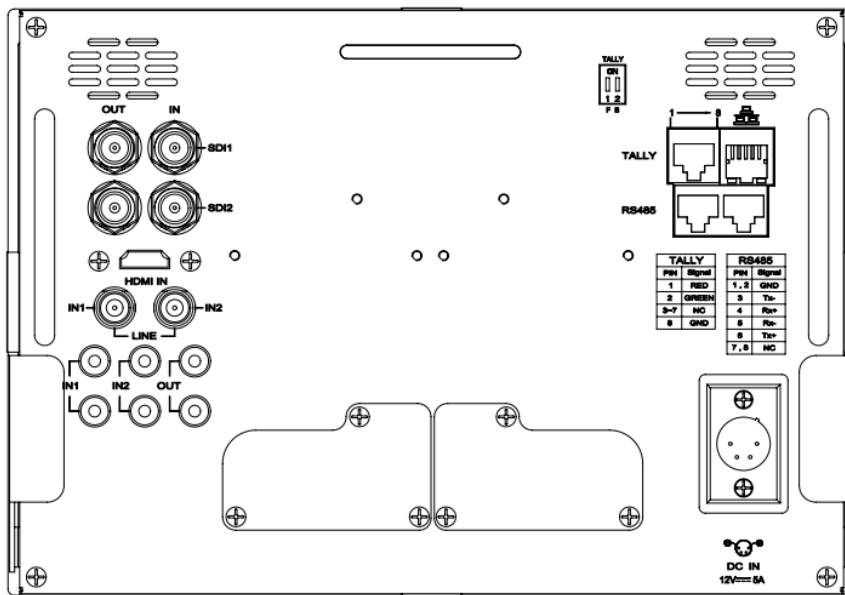
two battery plates

## 3. Dimensions

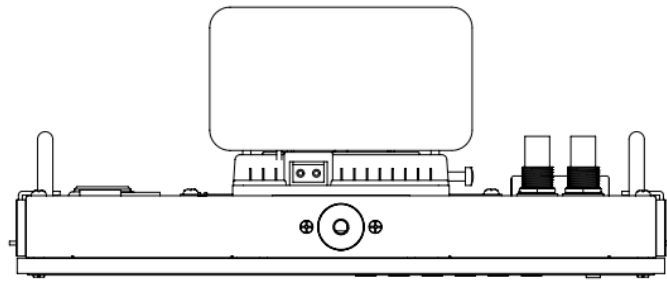
The description of the product dimensions of PRM1014 is shown as in the following figures:



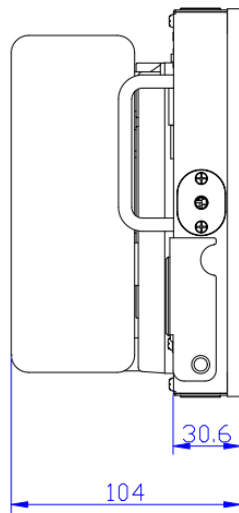
**Figure 7-1 Front Panel(Unit: mm)**



**Figure 7-2 Rear Panel(Unit: mm)**



**Figure 7-3 Top View(Unit: mm)**



**Figure 7-4 Side View(Unit: mm)**

**i Tips**

- Specifications are subject to change without notice.

-----No Text Below-----





FOR MORE INFORMATION PLEASE VISIT: <http://www.osee-dig.com/>  
OSEE TECHNOLOGY CO., LTD.  
No.22 Building, No.68 zone, Beiqing Road, Haidian District, Beijing, China  
Tel: (+86) 010-62434168, Fax: (+86) 010-62434169  
E-mail: [sales@osee-dig.com](mailto:sales@osee-dig.com)