

SAC6840N  
2X1 Switcher

USER MANUAL

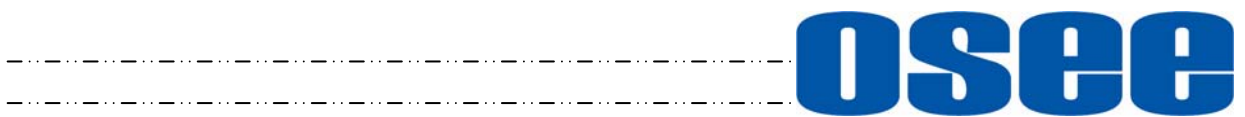



### **Product Information**

**Model:** SAC6840N 2X1 Switcher  
**Version:** V010001  
**Release Date:** June 30th, 2008

---

### **Company**

OSEE TECHNOLOGY CO., LTD.

---

### **Contact Information**

**Address:** No.22 Building, No.68 zone, Beiqing Road, Haidian District,  
Beijing, China  
**Post Code:** 100094  
**Tel:** (+86) 010-62434168  
**Fax:** (+86) 010-62434169  
**Web:** <http://www.osee-dig.com/>  
**E-mail:** [sales@osee-dig.com](mailto:sales@osee-dig.com)

# Contents

<b>Chapter 1 Introduction .....</b>	<b>1</b>
Overview .....	1
Features .....	1
Module Descriptions .....	2
Back Connector .....	2
SAC6840N .....	2
Signal Flow .....	3
<b>Chapter 2 Installation .....</b>	<b>3</b>
Overview .....	3
Maximum Power Ratings for Frame .....	4
Unpacking the Module .....	4
Preparing the Product for Installation .....	4
Check the Packing List .....	4
Installing the Module .....	4
Install the front panel. Making the Connections .....	5
Removing the Module .....	5
Setting Jumper .....	6
LED Indicator .....	6
GPI/GPO Interface .....	7
<b>Chapter 3 Operation and Control .....</b>	<b>7</b>
Switches and Key .....	7
<b>Chapter 4 Specifications .....</b>	<b>11</b>
SDI Video Input .....	11
SDI Video Output .....	12
Analog Composite Video Output .....	12
<b>Warranty for osee product .....</b>	<b>13</b>
What the warranty covers: .....	13
What the warranty does not cover: .....	13

# Chapter 1 Introduction

## Overview

The SAC6840N is a SD-SDI/ASI 2X1 switcher, supports clean switching, and the switching function of which is finished based on internal circuit. When power failure happens, the signal is still through depended on the relay located at back connector, simultaneously, the setting of output is not changed.

The module can work at two modes, either AUTO mode or MANUAL mode. To AUTO mode, switching happens when alarm occurs or internal status changes. To MANUAL mode, remote control panel is optional to the module.

The module can be installed in 6800N series frame.

**Tab. 1-1** Description of SAC6840N Switcher

Module	Description
SAC6840N	2 channels serial digital signal input, 1 channel analog reference input, 1 channel PGM output, 1 channel output of COMP or SD-SDI/ASI, ONET bus-mastering interface and GPI/GPO interface.

## Features

The SAC6840N offers the following features:

- ✓ PGM OUT characters bypass function, so the signal can't break.
- ✓ One channel of analog composite video signal which can pre-supervise the signal quality of input
- ✓ The outputs are reclocked signals
- ✓ Clean switching technique ensures video has no flickering, audio has no cacophony.
- ✓ Three control modes, AUTO mode, MANUAL mode and BYPASS mode.
- ✓ Auto mode based on freeze frame, black field, EDH, and audio status, such as loss, overload, parity error, and etc.
- ✓ 2X over-sampling and 10-bit D/A conversion ensure high-quality images.
- ✓ Can identify multi-format input, such as 525, 625, SDI and ASI signal
- ✓ Auto-equalizing technique can compensate 300m Belden 8281 cable.

## FCC Caution:

Any Changes or modifications not expressly approved by the party responsible for compliance could void the user's authority to operate the equipment.

This device complies with part 15 of the FCC Rules.

Operation is subject to the following two conditions: (1) This device may not cause harmful interference,

and (2) this device must accept any interference received, including interference that may cause undesired operation.

Note: This equipment has been tested and found to comply with the limits for a Class B digital device, pursuant to part 15 of the FCC Rules. These limits are designed to provide reasonable protection against harmful interference in a residential installation. This equipment generates uses and can radiate radio frequency energy and, if not installed and used in accordance with the instructions, may cause harmful interference to radio communications. However, there is no guarantee that interference will not occur in a particular installation. If this equipment does cause harmful interference to radio or television reception, which can be determined by turning the equipment off and on, the user is encouraged to try to correct the interference by one or more of the following measures:

Reorient or relocate the receiving antenna.

Increase the separation between the equipment and receiver.

Connect the equipment into an outlet on a circuit different from that to which the receiver is connected.

Consult the dealer or an experienced radio/TV technician for help.

## Module Descriptions

### Back Connector



**Fig.1-1** Back Connector of 6800-C2 frame

### SAC6840N

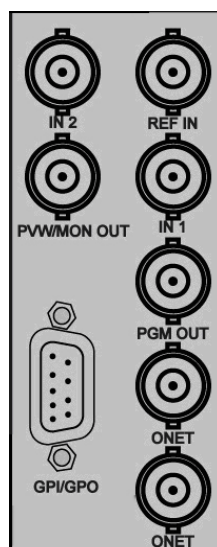
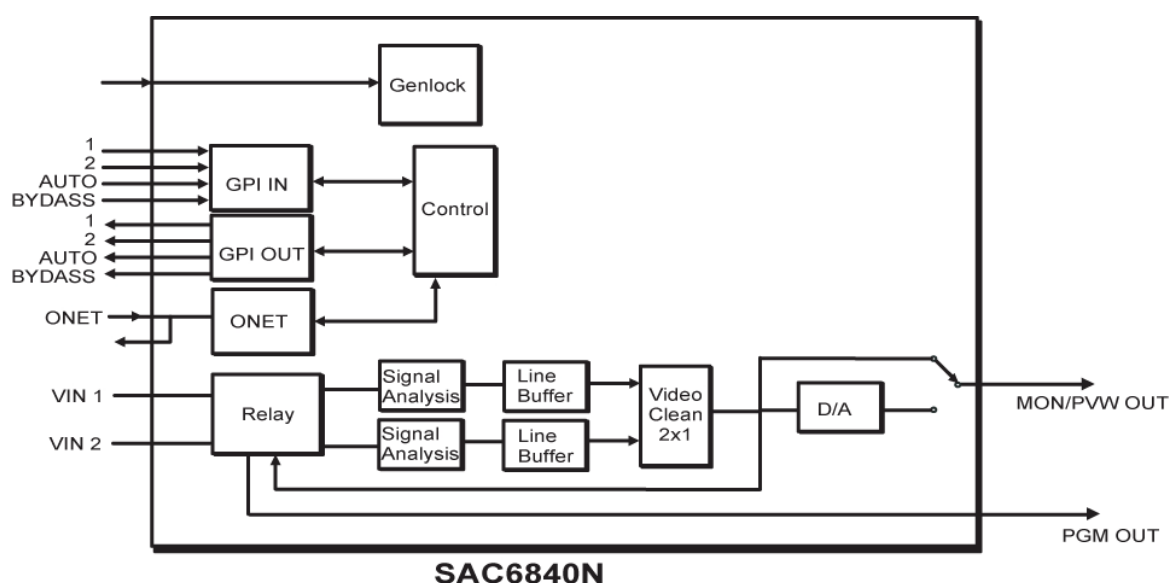

**Fig.1-2** Back Connector of SAC6840N

**Tab. 1-2** description of SAC6840N Back Connector

Item	Prescription
REF IN	Analog reference input
IN 1	Serial digital input 1
IN 2	Serial digital input 2
PGM OUT	Reclocked SDI video output (Bypass)
PVW/MON OUT	Reclocked SDI video output or analog composite output
ONET	ONET bus interface
GPI/GPO	GPI/GPO interface

## Signal Flow



**Fig. 1-3** Signal Flow of SAC6840N

## Chapter 2 Installation

### Overview

The power consumption for module and the maximum power ratings that frame can sustain have to be confirmed before installing the module.

In this chapter, the following topics on installation process for SAC6840N are discussed below:

- Unpacking the module
- Setting Jumper
- Installing the module
- Making the connections
- Removing the module

## Maximum Power Ratings for Frame

The maximum power ratings that different types of frames can sustain are listed in the Table 2-1

**Tab. 2-1** Maximum Power Consumption

Frame	Maximum Voltage	Redundant Power Supplies	Numbers of Slots
6800N-1U	40W	Yes	4
6800N-2U	60W	Yes	10

## Unpacking the Module

### Preparing the Product for Installation

Contact your dealer right now if any items are missing.

Follow the procedures below before installing the module:

- Check the equipment for any invisible damage that may have occurred during transit.
- Confirm all the items listed on the packing list have been received.
- Remove all the packing material including electrostatic-resistant packing.
- Retain these packing for future use.

### Check the Packing List

**Tab. 2-2** Packed Components

Model Name	Description
SAC6840N	SAC6840N module (1pc); back connector (1pc), and other accessories

## Installing the Module

**Caution:** Static electricity may cause sensitive semiconductor out of order. Avoid installing or removing the module in the electrostatic-induced environment.

Follow the following steps to install the module:

### Step 1

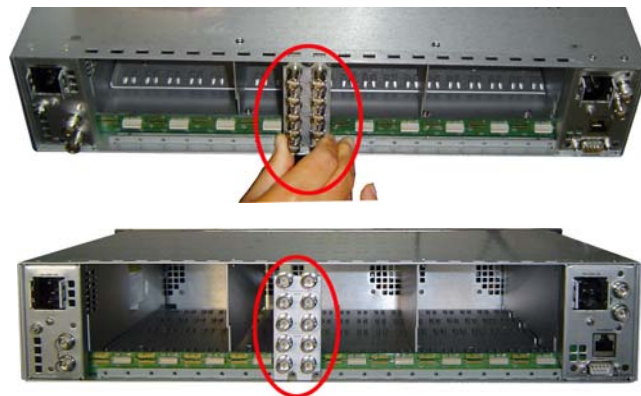



Step2



Step3



Step 4



Step5



**Fig. 2-1** Installation of 2U Frame of 6800N Series

- ✓ Locate the position for back connector and insert the back connector
- ✓ Fasten the screw to fix the back connector.
- ✓ Locate the slot for module.
- ✓ Get the module installed in the slot, push the module slightly along the slot, press module again to confirm that the module is installed firmly and then close swivel handle.
- ✓ Install the front panel.

## Install the front panel. Making the Connections

Please connect signals based on Fig. 1-2.

## Removing the Module

Follow the following steps to remove SAC6840N module:

1. Open the front part of frame.
2. Open the swivel handle to the full.



3. First make sure the frame stands firmly, and then pull the module gently along the slot till out of frame.
4. Install the front panel.

## Setting Jumper

**Tab. 2-3** Description of SAC6840N Jumpers

Item	Description
JP02 (used to choose control signal when communicating) Note: you must choose only one option	RXD_INT: remote control from 6800 series frame
	RXD_ONET: control signal from ONET remote control panel
	RXD_BOOT: reserved
JP03 (used to choose one signal of PVW/MON OUT in the back connector)	Used to choose which one will be output, Reclocked SDI video output or analog composite output
JP17 (used to choose reference signal )	FRM_REF: reference signal comes from common signal provided by 6800 series frame
	B_REF: reference signal is provided by Ref located at back connector
JP10 ON/OFF	Please set at ON if JP17 is at B_REF, While set at OFF if JP17 is at FRM_REF.

## LED Indicator

**Table 2-4** LED Indicator Function

Item (color)	Description
POWER (green)	On: Power is supplied.
Auto (green)	On: The device works on AUTO mode.
Bypass (green)	On: The device works on BYPASS mode.
OUT 1 (green)	On: output the first source
OUT 2 (green)	On: output the second source
SDI (green)	On: SD-SDI signal Off: ASI signal
SDT (green)	On: 625 Off: 525
1ER (orange)	On: there is error in the first source
2ER (orange)	On: there is error in the second source

## GPI/GPO Interface

**Tab. 2-5** the Definition of GPI/GPO pins

Pin	1	2	3	4	5	6	7	8	9
<b>Definition</b>	GPI0	GPI1	GPI2	GPI3	GND	GPO0	GPO1	GPO2	GPO3
<b>I/O Attribute</b>	Input	Input	Input	Input	Ground	Output	Output	Output	Output

**Tab. 2-6** GPI control prescription

GPI0	GPI1	GPI2	GPI3	Prescription	
0	0	0	X	MANUAL mode	Switch to the first source
		1	X		Switch to the second source
0	1	0	X	AUTO mode	It has no effect on the output when the status of GPI2 changes
		1	X		
1	0	0	X	BYPASS mode	Switch to the first source
		1	X		Switch to the second source
1	1	0/1	X	Invalid, no switch	

Note: switching can be fulfilled only when the module is in the control mode of BYPASS or MANUAL.

## Chapter 3 Operation and Control

### Switches and Key

Refer to **Figure 3-1** or **Table 3-1** (Bank 0) or **Table 3-2** (Bank 1) to complete control

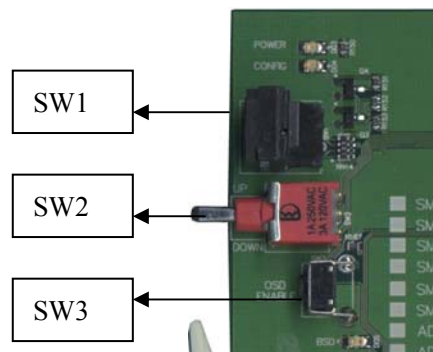

**Fig. 3-1** Switches and Key

Rotate SW1 at the position of 0, and select the proper Bank by SW2.

#### Bank Selection

The SW1 has two Banks

Rotate the SW1 at the position of “0”. The position of “0” is always used to select Bank.

Turn SW2 up or down to select Bank.

#### 1. SW1 Mode Selection

SW1 is a 16-position rotary switch, which is used to select the specific setting.  
The selection range is: 0, 1, 2, 3, 4, 5, 6, 7, 8, 9, A, B, C, D, E, F.

2. SW2 Mode Selection

SW2 is a toggle switch, which is used to decide the concrete figure of the setting made by SW1.  
SW2 is a 3-position toggle switch, used to decide the concrete figure of the setting made by SW1.  
To keep SW2 at the position of “UP” or “DOWN”, the continuous adjustment can be achieved.

3. SW3

Press the SW3 to activate OSD.

**Tab. 3-1** Bank 0 Function Setting

SW1 Position	Function	Options	Default
0	Select Bank	Bank 0, Bank 1 Bank 2, Bank 3 Bank 4	Bank 0
1	Select video standard	525 625 AUTO	AUTO
2	Select control mode	Bypass <sup>1</sup> Auto Manual	Auto
3	Auto switching mode	Switch to Switch back	Switch back
4	Select output signal	Source 2 Source 1	
5	Remote Control selection	Internal ONET	
6	Test signal	Color Bar Normal	Normal
7	OSD mode	Automatic On	On
8	reserve		
9	horizontal position of Tally	000--082	041
A	Alarming display	Realtime Normal	Normal
B	Audio Mon Sel	Out 1-2 Out 3-4	Out 3-4
C	Control the error of de-embedding	Bypass Mute	Bypass
D	V-bit mute	Enable/Disable	Enable

SW1 Position	Function	Options	Default
E	Reserve	Reserve	
F	Reserve	Reserve	

Note : 1 To BYPASS mode, the input signal is switched directly by relay with no processing by internal circuit.

**Tab. 3-2** Bank 1 SW1 Function Setting

SW1 position	Function	Options	Default
0	Select Bank	Bank 0, Bank 1 Bank 2, Bank 3 Bank 4	Bank 0
1	Select Audio Group	Group 1 Group 2 Group 3 Group 4	CH 1
2	Select the type of audio meter 1	NONE VU PEAK VU+ PEAK	VU+ PEAK
3	Select the type of audio meter 2	NONE VU PEAK VU+ PEAK	VU+ PEAK
4	The horizontal position of audio meter 1	000~255	8
5	The horizontal position of audio meter 2	000~255	165
6	Select audio test level	-18dB -20dB	-20dB
7	Freeze threshold	0~255	30
8	Freeze delay	0~255	050 Frames
9	Motion Delay	0~255	100 Frames
A	Black field delay	0~255	050 Frames
B	EDH error threshold	0~255	040 Fields
C	EDH error number	0~32768	
D~F	reserve	reserve	

**Tab. 3-3** Bank 2 SW1 Function Setting

<b>SW1 Position</b>	<b>Function</b>	<b>Options</b>	<b>Default</b>
0	Select Bank	Bank 0, Bank 1 Bank 2, Bank 3 Bank 4	Bank 0
1	Carrier En.	Enable/Disable	Disable
2	Lock En.	Enable/Disable	Enable
3	EDH En.	Enable/Disable	Disable
4	EDH Err En.	Enable/Disable	Disable
5	In1 Freeze En.	Enable/Disable	Disable
6	In1 BB En.	Enable/Disable	Disable
7	In1 G1 Loss En.	Enable/Disable	Disable
8	In1 G2 Loss En.	Enable/Disable	Disable
9	In1 G3 Loss En.	Enable/Disable	Disable
A	In1 G4 Loss En.	Enable/Disable	Disable
B	In1 CH1 Mute En.	Enable/Disable	Disable
C	In1 CH2 Mute En.	Enable/Disable	Disable
D	In1 CH3 Mute En.	Enable/Disable	Disable
E	In1 CH4 Mute En.	Enable/Disable	Disable
F	Reserved		

**Tab. 3-4** Bank 3 SW1 Function Setting

<b>SW1 Position</b>	<b>Function</b>	<b>Options</b>	<b>Default</b>
0	Select Bank	Bank 0, Bank 1 Bank 2, Bank 3 Bank 4	Bank 0
1	In2 Freeze En.	Enable/Disable	Disable
2	In2 BB En.	Enable/Disable	Disable
3	In2 G1 Loss En.	Enable/Disable	Disable
4	In2 G2 Loss En.	Enable/Disable	Disable
5	In2 G3 Loss En.	Enable/Disable	Disable

SW1 Position	Function	Options	Default
6	In2 G4 Loss En.	Enable/Disable	Disable
7	In2 CH1 Mute En.	Enable/Disable	Disable
8	In2 CH2 Mute En.	Enable/Disable	Disable
9	In2 CH3 Mute En.	Enable/Disable	Disable
A	In2 CH4 Mute En.	Enable/Disable	Disable
B~F	Reserved		

**Tab. 3-5** Bank 4 SW1 Function Setting

SW1 position	Function	Options	Default
0	Select Bank	Bank 0, Bank 1 Bank 2, Bank 3 Bank 4	Bank 0
1	Auto phase	625:0—1074999 525: 0--800899	
2	Auto timing	Press to set	
3~E	Reserved	Reserve	
F	Restore the default of parameters	Press to set	

Note: Bank 2 and Bank 3 determine which criterion is in operation.  
 Enable: the criterion is in operation; Disable: the criterion is invalid.

## Chapter 4 Specifications

In this chapter, the specifications in the following subjects are introduced:

- ✓ SDI Video Input
- ✓ SDI Video Output
- ✓ Analog Composite Video Output

### SDI Video Input

**Table 4-1** SDI Video Input Specifications

Item	Parameter
Standards	SMPTE 259M-C, 270 Mbps, 525/625 SDI Component
Impedance	75Ω termination
Return Loss	>18dB to 360MHz

Item	Parameter
Connector	BNC (IEC169-8)
Equalization	Auto to 30dB@270 Mbps

## SDI Video Output

**Table 4-2** SDI Video Output Specifications

Item	Parameter
Standards	SMPTE 259M-C, 270 Mbps, 525/625 SDI component
Connector	BNC (IEC169-8)
Impedance	75Ω
Return Loss	>18dB to 270MHz
Signal Level	800 mV ± 10%
DC Offset	0 V ± 0.5 V
Rise/Fall Time	400 to 1500ps (20% to 80% of amplitude)
Overshoot	<10%
Jitter	<0.2 UI (740ps) Peak

## Analog Composite Video Output

**Table 4-3** Analog Composite Video Output Specifications

Item	Parameter
Standards	NTSC, PAL or PAL-M
Level	1Vp-p±/-3dB
Impedance	75 Ω
Return Loss	>40 dB to 5 MHz
DC Offset	0V±0.05 V
Frequency Response	±0.2 dB to 5 MHz
Differential Gain	<1%
Differential Phase	<1.5°
Signal to noise	75dB to 5.75MHz

Note: Specifications are subject to change without notice



## Warranty for osee product

### What the warranty covers:

osee warrants its products to be free from defects in material and workmanship during the warranty period of two year from purchase date. If a product proves to be defective in material or workmanship during the warranty period, osee will, at its sole option, repair or replace the product with a similar product. The replacement unit will be covered by the balance of the time remaining on the customer's original limited warranty.

No sales personnel of the seller or any other person is authorized to make any warranties other than those described above, or to extend the duration of any warranties on behalf of osee, beyond the time period describe above.

This warranty is extended to the first consumer only, and proof of purchase is necessary to honor the warranty. If there is no proof of purchase provided with a warranty claim, osee reserves the right not to honor the warranty set forth above. Therefore, labor and parts may be charged to the consumer.

### What the warranty does not cover:

1. Any product on which the serial number has been defaced, modified or removed.
2. Damage, deterioration or malfunction resulting from:
  - Accident, misuse, neglect, fire, water, lightning, or other acts of nature, unauthorized product modification, or failure to follow instructions supplied with the product
  - Repair or attempted repair by anyone not authorized by osee
  - Any damage of the product due to shipment.
  - Removal or installation of the product.
  - Causes external to the product, such as electric power fluctuations or failure.
  - Use of supplies or parts not meeting osee product's specifications.
  - Normal wear and tear.
  - Any other cause which does not relate to a product defect.