

**SDM6801N-M4**  
**SD-SDI Video Distribution**  
**and Monitoring Module**

**USER MANUAL**

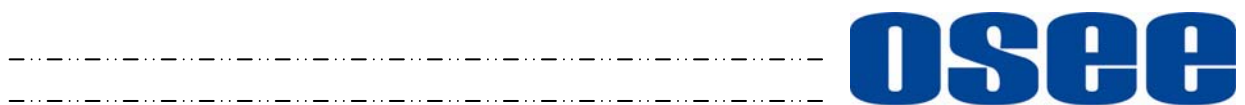



### **Product Information**

**Model:** SDM6801N-M4 SD-SDI Video Distribution and Monitoring Module  
**Version:** V010000  
**Release Date:** February 16th, 2011

---

### **Company**

OSEE TECHNOLOGY CO., LTD.

---

### **Contact Information**

**Address:** No.22 Building, No.68 zone, Beiqing Road, Haidian District,  
Beijing, China  
**Post Code:** 100094  
**Tel:** (+86) 010-62434168  
**Fax:** (+86) 010-62434169  
**Web:** <http://www.osee-dig.com/>  
**E-mail:** [sales@osee-dig.com](mailto:sales@osee-dig.com)

# Contents

<b>Chapter 1 Introduction.....</b>	<b>1</b>
<b>Overview .....</b>	<b>1</b>
<b>General Description .....</b>	<b>1</b>
<b>Features.....</b>	<b>1</b>
<b>Module Description.....</b>	<b>2</b>
<b>The front Side of Module.....</b>	<b>2</b>
<b>Back Connector .....</b>	<b>3</b>
<b>Back Connector of SDM6801N-M4 .....</b>	<b>3</b>
<b>Signal Flow .....</b>	<b>4</b>
<b>Chapter 2 Installation.....</b>	<b>4</b>
<b>Overview .....</b>	<b>4</b>
<b>Maximum Power Ratings for Frame.....</b>	<b>4</b>
<b>Unpacking the Module.....</b>	<b>4</b>
<b>Check the Packing List .....</b>	<b>4</b>
<b>Preparing the Product for Installation .....</b>	<b>4</b>
<b>Installing the Module .....</b>	<b>5</b>
<b>Making the Connections.....</b>	<b>6</b>
<b>Module Removal .....</b>	<b>6</b>
<b>Chapter 3 Operation and Control .....</b>	<b>6</b>
<b>Instructions on Control and Operation.....</b>	<b>6</b>
<b>OSD Menu .....</b>	<b>7</b>
<b>Instructions on Parameters Setting .....</b>	<b>10</b>
<b>LED .....</b>	<b>10</b>
<b>Chapter 4 Specifications .....</b>	<b>11</b>
<b>SDI Video Input .....</b>	<b>11</b>
<b>SDI Video Output.....</b>	<b>11</b>
<b>Analog Composite Output .....</b>	<b>11</b>
<b>Power Consumption.....</b>	<b>12</b>
<b>Chapter 5 Warranty for osee product.....</b>	<b>13</b>
<b>What the warranty covers:.....</b>	<b>13</b>
<b>What the warranty does not cover: .....</b>	<b>13</b>

## Chapter 1 Introduction

### Overview

In this manual, the module of SD-SDI monitoring reclocked distribution amplifier with different models have been introduced as follows:

SDM6801N-M4: Supporting one SDI input, two (four) channels CVBS with audio meters monitoring, six (four) channels re-clocked SD-SDI outputs.

### General Description

The SDM6801N-M4 provides standard SDI input, reclocked SDI output and analog composite video output with audio meters. The SDM6801N-M4 is equipped with card edge setting for ease of operation.

To deliver the high quality image, the SDM6801N-M4 adopts 2X oversampling and 10-bit D/A conversion so as to reduce the artificial distortion.

The SDM6801N-M4 provides analog composite output with audio meters, which supports NTSC, PAL-M or PAL. Apart from the function of monitoring SDI, the SDM6801N-M4 can also provide reclocked SDI output. The automatic cable equalization for input can compensate up to 300m Belden 8281 to deliver error-free output.

The SDM6801N-M4 allows the users to make their own setting to adjust the module to working in the proper format. The SDM6801N-M4 can be controlled via the switch on the front panel.

Table 1-1 gives the descriptions of modules of different models.

**Table 1-1** SDM6801N-M4

Module	Description
SDM6801N-M4	One channel SDI input, 2 (4) CVBS with audio meters or 6 (4) reclocked SD-SDI outputs.

### Features

The SDM6801N-M4 offers the following features:

1. Flexibility in Design  
The SDM6801N-M4 provides multi-configuration for user to choose from. It can serve as distribution amplifier with CVBS preview
2. Able to Adjust to Multi-Format  
The SDM6801N-M4 can work in either 525 or 625, where auto-detect is allowed. The digital processing ensures high coding precision with no need of adjustment, meanwhile offering high reliability for long hours.
3. Ancillary Data and EDH  
The SDM6801N-M4 can accept all ancillary data and EDH and output them with no changes.
4. Auto Input Equalization  
The automatic cable equalization for input can compensate up to 300m Belden 8281 so as to deliver error-free output.

**FCC Caution:**

Any Changes or modifications not expressly approved by the party responsible for compliance could void the user's authority to operate the equipment.

This device complies with part 15 of the FCC Rules.

Operation is subject to the following two conditions: (1) This device may not cause harmful interference, and (2) this device must accept any interference received, including interference that may cause undesired operation.

Note: This equipment has been tested and found to comply with the limits for a Class B digital device, pursuant to part 15 of the FCC Rules. These limits are designed to provide reasonable protection against harmful interference in a residential installation. This equipment generates uses and can radiate radio frequency energy and, if not installed and used in accordance with the instructions, may cause harmful interference to radio communications. However, there is no guarantee that interference will not occur in a particular installation. If this equipment does cause harmful interference to radio or television reception, which can be determined by turning the equipment off and on, the user is encouraged to try to correct the interference by one or more of the following measures:

- Reorient or relocate the receiving antenna.
- Increase the separation between the equipment and receiver.
- Connect the equipment into an outlet on a circuit different from that to which the receiver is connected.
- Consult the dealer or an experienced radio/TV technician for help.

**Module Description**

**The front Side of Module**

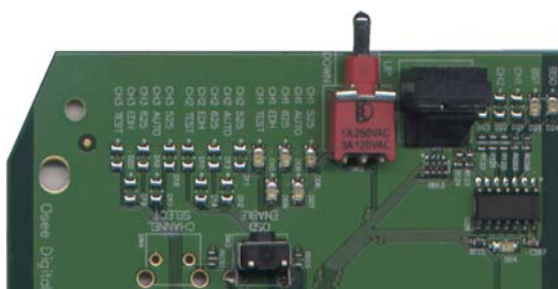

**Figure 1-1** SDM6801N-M4

The descriptions of control switch and status LED are shown in the following Table 1-2.

**Table 1-2** Control Switch and LED Indicator

<b>Function</b>	<b>Descriptions</b>
Status LED	The different combinations of LED indicator indicate the working status of module. Refer to chapter 3 for more information about LED.
SW1 Rotary Switch	The SW1 is a 16-position rotary switch, used to select specific setting.
SW2 Toggle Switch	The SW2 is a 3-location toggle switch. It's used to adjust to the selected parameters by SW1. "+" indicates SW2 goes up, and "-" means SW2 goes

	down. Keeping SW1 at the position of “UP” or “DOWN”, the continuous adjustment can be achieved.
--	---

**Back Connector**



**Back Connector of SDM6801N-M4**

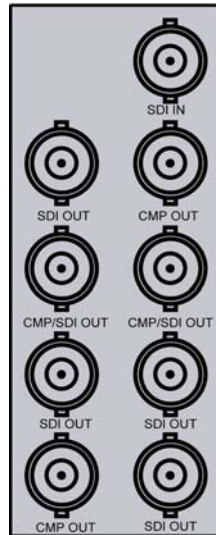
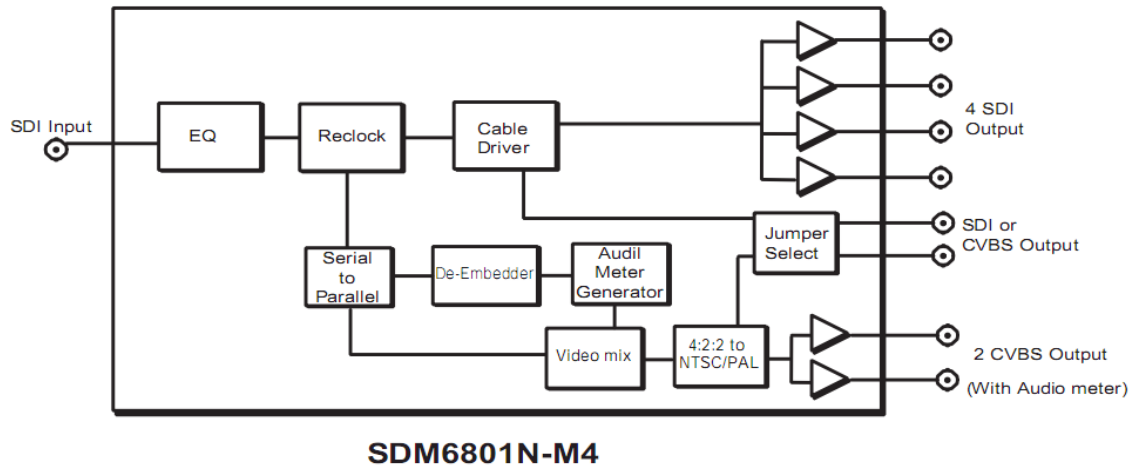

**Figure 1-2** the Back Connector of SDM6801N-M4

**Table 1-3** the Back Connector of SDM6801

<b>Location</b>	<b>Descriptions</b>
IN SDI IN	SDI Input: Indicating SDI signal has 75 Ω termination
1 CMP OUT	CVBS output with audio meters
2 SDI OUT	Reclocked SDI output
3 CMP/ SDI OUT	Either CVBS output with audio meters or relocked SDI output (selectable)
4 CMP/ SDI OUT	Either CVBS output with audio meters or relocked SDI output (selectable)
5 SDI OUT	Reclocked SDI output
6 SDI OUT	Reclocked SDI output
7 SDI OUT	Reclocked SDI output
8 CMP OUT	CVBS output with audio meters

**Signal Flow**



**Figure 1-3** Basic signal flow of SDM6801N-M4

**Chapter 2 Installation**

**Overview**

The power dissipation of module and maximum power ratings that frame can sustain has to be confirmed before installation.

The following topics on installation process of SDM6801N-M4 will be introduced in this chapter below:

1. Unpacking the Module
2. Setting Jumper
3. Installing the Module
4. Making the Connections
5. Module Removal

**Maximum Power Ratings for Frame**

Maximum power ratings that different frames can sustain are listed in the Table 2-1.

**Table 2-1** Maximum Power Ratings

Frame	Maximum Voltage	Redundant Power Supplies	Numbers of Slots
6800N-1U	40W	Yes	4
6800N-2U	60W	Yes	10

**Unpacking the Module**

**Check the Packing List**

**Table 2-2** Packed Components

Model No	Module
SDM6801N-M4	SDM6801N-M4 module: 1pc; Back connector: 1set

**Preparing the Product for Installation**

Contact your dealer right away if any items are missing.



Follow the steps below before module installation:

1. Check the equipment if any damage may have occurred during the transit.
2. Confirm that all items on the packing list have been received.
3. Remove all the packing materials as well as electrostatic-resistant packing if available for the equipment.
4. Keep these packing for future use.

## Installing the Module

**Caution:** Static electricity may cause sensitive semiconductor out of order. Avoid installing or removing the module in the electrostatic-induced environment.

Follow the next steps to install the module:

### Step 1

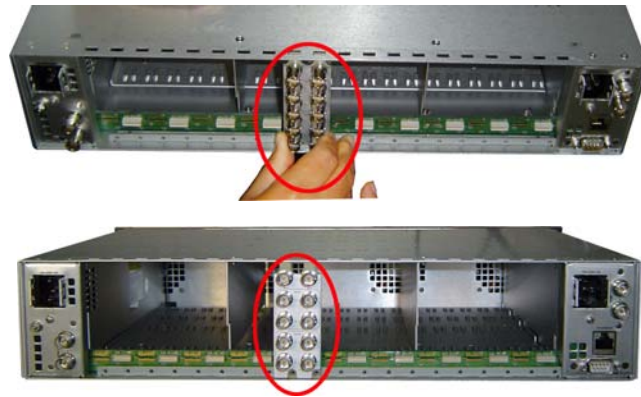

### Step2



### Step3



### Step 4



Step5



**Fig. 2-1** Installation of 2U Frame of 6800N Series

1. Locate the position for back connector and insert the back connector
2. Fasten the screw to fix the back connector.
3. Locate the slot for module.
4. Get the module installed in the slot, push the module slightly along the slot, press module again to confirm that the module is installed firmly and then close swivel handle.
5. Install the front panel.

### Making the Connections

Make corresponding signal connections based on the module type you purchased. Refer to **Table 1-2** for interface.

### Module Removal

When removing the SDM6801N-M4, Observe the following steps:

1. Open the front panel.
2. Open the swivel handle to the full.



3. Hold the swivel handle; pull the module along the slot out of frame.
4. Take out the module and install the front panel.

## Chapter 3 Operation and Control

All the functions and working modes of SDM6801N-M4 are introduced on the following subjects in this chapter:

- Instructions on User Control and Operation
- OSD Menu
- Instructions on Parameter Setting
- Instructions on LED Indicator

### Instructions on Control and Operation

Refer to **Figure 3-1** or **Table 3-1** (Bank 0) to complete control.

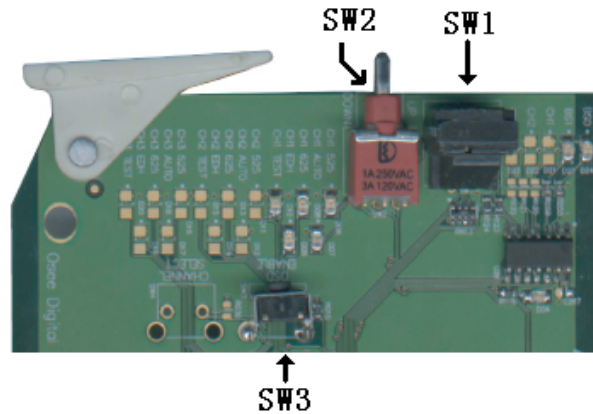

**Figure 3-1** The Positions of SW1 SW2 and SW3

Make SW1 at the position of 0, and select the proper Bank by SW2.

**Bank Selection**

The SW1 has three Banks

Set the SW1 at the position of “0”. The position of “0” is always used to select Bank.

Set the SW2 at the position of “UP” to select Bank 0, LED of Bank 1 is off. Set the SW2 at the position of “DOWN” to select Bank, LED of Bank 1 is on.

Set the SW1 as default, Refer to Table 3-1 for default

**1. SW1 Mode Selection**

The SW1 is a 16-position rotary switch, which is used to select the specific setting.

The selection range is: 0, 1, 2, 3, 4, 5, 6, 7, 8, 9, A, B, C, D, E, F.

**2. SW2 Mode Selection**

The SW2 is a 3-position toggle switch, used to decide the concrete figure of the setting made by SW1.

To keep the SW2 at the position of “UP” or “DOWN”, the continuous adjustment can be achieved.

**3. SW3**

Press the SW3 to activate OSD.

**OSD Menu**

**Table 3-1** Bank 0 SW1 Function Setting

SW1 Location	Function	UP: SW2+ DOWN: SW2-	Default
0	Select Bank	0:0 Bank Select Bank 0/1/2	Bank 0
1	Select Mode	0:1 SDI Vid Std 525/625/Auto	Auto
2	Select standards Only for 525	0:2 Out 525 Std NTSC PAL-M	NTSC

3	Video setup Only for 525	0:3 Video Setup ON/OFF	ON
4	Chrominance	0:4 Chroma Enable/Disable	Enable
5	Select Test Signal	0:5 Test Signal ON/OFF	OFF
6	Select Audio Group	0:6 Aud Group Group 1/2/3/4	Group 1
7	Select the display type of audio meter1(CH1A , CH1B)	0:7 Meter1 Type: Off/VU/PPM/VU+PPM	VU+PPM
8	Select the display type of audio meter2(CH2A , CH2B)	0:8 Meter2 Type: Off/VU/ PPM/VU+PPM	VU+PPM
9	Select the horizontal position of audio Meter1 (CH1A, CH1B)	0: 9 Meter1 H Pos: 5 to 168	7
A	Select the horizontal position of audio Meter2 (CH2A, CH2B)	0:A Meter2 H Pos: 5 to 168	168
B	Select the test level of audio meter.	0:B Test Level: -18dB/-20dB	-18dB
C~E	Reserved	Reserve	
F	Default	0:F Recall Def Restore? Restored	

**Table 3-2** Bank 1 SW1 Function Setting

SW1 Location	Function	UP: SW2+ DOWN: SW2-	Default
0	Select Bank	0:0 Bank Select Bank 0/1/2	Bank 0
1	Black Field Threshold	1:1 Black Thd 0~255	30
2	Freeze Frame Delay	1:2 Freeze Delay 0~255	30
3	Freeze Frame Threshold	1:3 Freeze Thd 0~255	30
4	No Audio Delay	1:4 No Aud Delay 0~255	30
5	No Audio Standards to Select	1:5 No Aud Thd -72/-66 /-60 /-54 /-48 dB	-60dB

6	EDH Detect	1:6 EDH Packet Detect EDH No EDH	Read only
7	EDH Error Number	1:7 EDH Err Num 0~65535	Read only
8	Input Video Standard	1:8 In Video Std 525/625	Read Only
9	SDI Status	1:9 SDI Stu Detect/Loss	Read Only
A	SDI Black Field	1:A SDI BLACK Black/No	Read Only
B	SDI Freeze Frame	1:B SDI FREEZE Freeze/No	Read Only
C~E	Reserved	Reserve	
F	Module Information	1:F Device SDM6801N-M4	

**Table 3-3** Bank 2 SW1 Function Setting

<b>SW1 Location</b>	<b>Function</b>	<b>UP: SW2+ DOWN: SW2-</b>	<b>Default</b>
0	Select Bank	0:0 Bank Select Bank 0/1/2	Bank 0
1	Goup1 Status	2:1 Group1 Pres Present/No	Read only
<b>SW1 Location</b>	<b>Function</b>	<b>UP: SW2+ DOWN: SW2-</b>	<b>Default</b>
2	Goup2 Status	2:2 Group2 Pres Present/No	Read only
3	Goup3 Status	2:3 Group3 Pres Present/No	Read only
4	Goup4 Status	2:4 Group4 Pres Present/No	Read only
5	Audio Channel 1A Status	2:5 CH1A Signal Detect Sig/No signal	Read only
6	Audio Channel 1B Status	2:6 CH1B Signal Detect Sig/No signal	Read only
7	Audio Channel 2A Status	2:7 CH2A Signal Detect Sig/No signal	Read only
8	Audio Channel 2B Status	2:8 CH2B Signal Detect Sig/No signal	Read Only

9	The overload status of Audio Channel 1A	2:5 CH1A Overlod Detect Sig/No Overload	Read Only
A	The overload status of Audio Channel 1B	2:6 CH1B Overlod Detect Sig/No Overload	Read Only
B	The overload status of Audio Channel 2A	2:7 CH2A Overlod Detect Sig/No Overload	Read Only
C	The overload status of Audio Channel 2B	2:8 CH2B Overlod Detect Sig/No Overload	Read Only
D	Reserved	Reserve	
E	Software version	FW2.1	
F	Module Information	2:F Device SDM6801N-A4	

### Instructions on Parameters Setting

When the SDM6801N-M4 is powered on, its default status is Bank 0.

Through ERROR Detect, identify whether the input signal or reference signal is correct or not.

Keeping the SW2 at the position of “UP” or “DOWN” , a continuous adjustment can be achieved.

When the SW1 rotated to the position of “F” during Bank 0, and take SW2 up or down, the parameters will be restored to the default.

### LED

**Table 3-3** LED Indicator Function

Item	Color	Description
BS0、BS1	Orange	On. Indicates Bank figure and set figure in binary.
CH1 525	Green	On. Working in 525.
CH1 AUTO	Green	On. Working in a format by detecting automatically.
CH1 625	Green	On, Working in 625.
CH1 EDH	Green	If LED is on, it indicates EDH is correct. While LED is flickering, it indicates EDH is wrong. If LED is off, it shows

		no EDH.
CH1 TEST	Orange	On. Preview signal outputs test signal.

## Chapter 4 Specifications

In this chapter, the specifications of SDM6801N-M4 on the following subjects are introduced:

- SDI Video Input
- SDI Video Output
- Analog Composite Video Output

### SDI Video Input

Signal Standard	SMPTE 259M-C; 270 Mbps, 525/625 SD component
Connector	BNC( IEC 169-8)
Impedance	75 ohm
Return Loss	>18dB to 270MHz
Maximum input cable	>300m

### SDI Video Output

Output	Up to 6 channels of SDI outputs (2 jumpers selectable)
Connector	BNC (IEC 169-8)
Overshoot	<10% (all outputs terminated)
Impedance	75 ohm
Return Loss	>18dB to 270MHz
Signal Level	800mV +/- 10%
Jitter	<0.2 UI
Rise and Fall Time	0.4-0.7nS (20% to 80% of amplitude)

### Analog Composite Output

Standards	NTSC, PAL-M, PAL-B
Number of Outputs	Up to 4 channels of CVBS outputs (2 jumpers selectable)
Signal Level	1 Vp-p nominal (+/- 10% adjustable)
DC Offset	0 mV +/- 14 mV (2 IRE)
Impedance	75 ohm
Return Loss	>40dB to 5.75 MHz
Output Quantization	10 bits
Frequency Response	<+/-0.25 dB to 5 MHz
Differential Gain	<1.5%
Differential Phase	<1.2°
S/N Ratio	>54dB RMS to 5 MHz
Test Signal	color bar: 100/0/75/0

**Power Consumption**

Power	< 3.3 W
Positive Rail	450 mA
Negative Rail	10mA

**Note: Specifications are subject to change without notice!**



## Chapter 5 Warranty for osee product

### What the warranty covers:

osee warrants its products to be free from defects in material and workmanship during the warranty period of two years from purchase date. If a product proves to be defective in material or workmanship during the warranty period, osee will, at its sole option, repair or replace the product with a similar product. The replacement unit will be covered by the balance of the time remaining on the customer's original limited warranty.

No sales personnel of the seller or any other person is authorized to make any warranties other than those described above, or to extend the duration of any warranties on behalf of osee, beyond the time period describe above.

This warranty is extended to the first consumer only, and proof of purchase is necessary to honor the warranty. If there is no proof of purchase provided with a warranty claim, osee reserves the right not to honor the warranty set forth above. Therefore, labor and parts may be charged to the consumer.

### What the warranty does not cover:

1. Any product on which the serial number has been defaced, modified or removed.
2. Damage, deterioration or malfunction resulting from:
  - Accident, misuse, neglect, fire, water, lightning, or other acts of nature, unauthorized product modification, or failure to follow instructions supplied with the product
  - Repair or attempted repair by anyone not authorized by osee
  - Any damage of the product due to shipment.
  - Removal or installation of the product.
  - Causes external to the product, such as electric power fluctuations or failure.
  - Use of supplies or parts not meeting osee product's specifications.
  - Normal wear and tear.
  - Any other cause which does not relate to a product defect.