

SDM6803N SD-SDI Monitoring and
Reclocked SDI with CVBS Output

USER MANUAL

Product Information

Model: SDM6803N SD-SDI Monitoring and Reclocked SDI with CVBS Output
Version: V010000
Release Date: April 1st, 2008

Company

OSEE TECHNOLOGY CO., LTD.

Contact Information

Address: No.22 Building, No.68 zone, Beiqing Road, Haidian District, Beijing, China
Post Code: 100094
Tel: (+86) 010-62434168
Fax: (+86) 010-62434169
Web: <http://www.osee-dig.com/>
E-mail: sales@osee-dig.com

Contents

Chapter 1 Introduction	1
Overview	1
General Description	1
Features	1
Module Description.....	2
The front Side of Module.....	2
Back Connector.....	3
Back Connector of SDM6803N	3
Signal Flow	4
Chapter 2 Installation	4
Overview.....	4
Maximum Power Ratings for Frame.....	4
Unpacking the Module.....	4
Preparing the Product for Installation	4
Check the Packing List.....	5
Installing the Module	5
Making the Connections	6
Module Removal.....	6
Chapter 3 Operation and Control.....	6
Instructions on Control and Operation.....	6
Instructions on Parameters Setting.....	9
LED.....	10
Chapter 4 Specifications	11
SDI Video Input	11
SDI Video Output.....	11
Analog Composite Video Output.....	12
Chapter 5 Warranty for osee product	13
What the warranty covers:	13
What the warranty does not cover:.....	13

SDM6803N SD-SDI Monitoring and Reclocked SDI with CVBS Output

Chapter 1 Introduction

Overview

In this manual, the module of SD-SDI monitoring relocked distribution amplifier with different models have been introduced as follows:

SDM6803N: Supporting triple SDI inputs. And each input has one relocked SDI output and one CVBS output.

General Description

The SDM6803N provides standard SDI input, relocked SDI output and analog composite video output. The SDM6803N is equipped with card edge setting for ease of operation.

To deliver the high quality image, the SDM6803N adopts 2X oversampling and 10-bit D/A conversion so as to reduce the artificial distortion.

The SDM6803N provides analog composite output, which supports NTSC, PAL-M or PAL. Apart from the function of monitoring SDI, the SDM681N can also provide relocked SDI output. The automatic cable equalization for input can compensate up to 300m Belden 8281 to deliver error-free output.

The SDM6803N allows the users to make their own setting to adjust the module to working in the proper format..

The SDM6803N can be controlled via the switch on the front panel. Table 1-1 gives the descriptions of modules of different models.

Table 1-1 SDM6803N

Module	Description
SDM6803N	Triple SDI inputs. Each input has one CVBS, and 1 SD-SDI Output

Features

The SDM6803N offers the following features:

1. Flexibility in Design
The SDM6803N provides multi-configuration for user to choose from. It can work as triple channel distribution amplifier with CVBS preview
2. Able to Adjust to Multi-Format
The SDM6803N can work in either 525 or 625, where auto-detect is allowed. The digital processing ensures high coding precision with no need of adjustment, meanwhile offering high reliability for long hours.
3. Ancillary Data and EDH
The SDM6803N can accept all ancillary data and EDH and output them with no

changes.

4. Auto Input Equalization

The automatic cable equalization for input can compensate up to 300m Belden 8281 so as to deliver error-free output.

FCC Caution:

Any Changes or modifications not expressly approved by the party responsible for compliance could void the user's authority to operate the equipment.

This device complies with part 15 of the FCC Rules.

Operation is subject to the following two conditions: (1) This device may not cause harmful interference, and (2) this device must accept any interference received, including interference that may cause undesired operation.

Note: This equipment has been tested and found to comply with the limits for a Class B digital device, pursuant to part 15 of the FCC Rules. These limits are designed to provide reasonable protection against harmful interference in a residential installation. This equipment generates uses and can radiate radio frequency energy and, if not installed and used in accordance with the instructions, may cause harmful interference to radio communications. However, there is no guarantee that interference will not occur in a particular installation. If this equipment does cause harmful interference to radio or television reception, which can be determined by turning the equipment off and on, the user is encouraged to try to correct the interference by one or more of the following measures:

Reorient or relocate the receiving antenna.

Increase the separation between the equipment and receiver.

Connect the equipment into an outlet on a circuit different from that to which the receiver is connected.

Consult the dealer or an experienced radio/TV technician for help.

Module Description

The front Side of Module

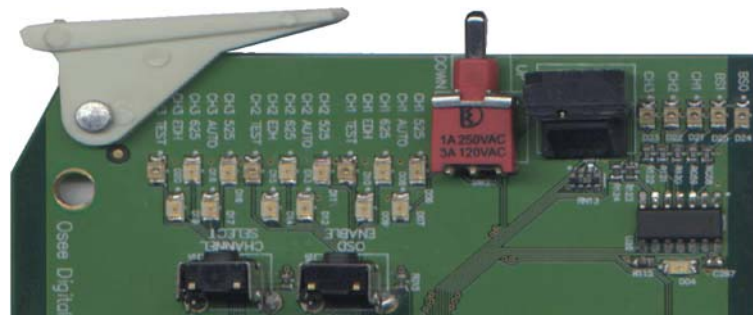

Figure 1-1 SDM6803N

The descriptions of control switch and status LED are shown in the following Table 1-2.

Table 1-2 Control Switch and LED Indicator

Function	Descriptions
----------	--------------

Status LED	The different combinations of LED indicator indicate the working status of module. Refer to chapter 3 for more information about LED.
SW1 Rotary Switch	The SW1 is a 16-position rotary switch, used to select specific setting.
SW2 Toggle Switch	The SW2 is a 3-location toggle switch. It's used to adjust to the selected parameters by SW1.

Back Connector



Back Connector of SDM6803N

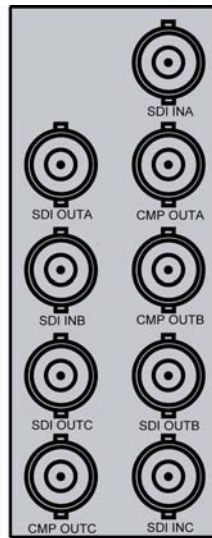

Figure 1-2 The Back Connector of SDM6803N

Table 1-3 Back Connector of SDM6803

Location	Descriptions
SDI INA	SDI input A
1 CMP OUT A	CVBS output A
2 SDI OUT A	Reclocked SDI output A
3 CMP OUT B	CVBS output B
4 SDI IN B	SDI input B
5 SDI OUT B	Reclocked SDI output B
6 SDI OUT C	Reclocked SDI output C
7 SDI INC	SDI input C
8 CMP OUT C	CVBS output C

Signal Flow

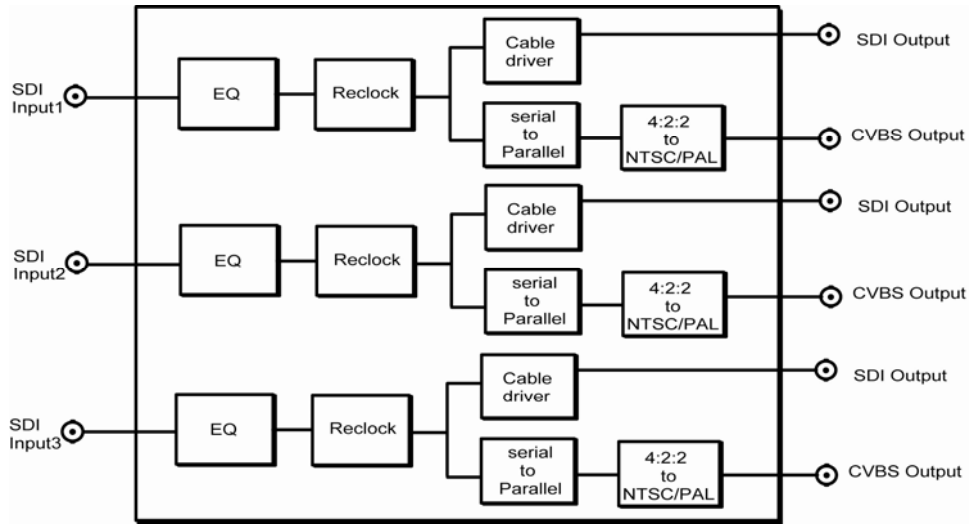

Figure 1-3 Basic signal flow of SDM6803N

Chapter 2 Installation

Overview

The power dissipation of module and maximum power ratings that frame can sustain has to be confirmed before installation.

The following topics on installation process of SDM6803N will be introduced in this chapter below:

1. Unpacking the Module
2. Setting Jumper
3. Installing the Module
4. Making the Connections
5. Module Removal

Maximum Power Ratings for Frame

Maximum power ratings that different frames can sustain are listed in the Table 2-1.

Table 2-1 Maximum Power Ratings

Frame	Maximum Voltage	Redundant Power Supplies	Numbers of Slots
6800N-1U	40W	Yes	4
6800N-2U	60W	Yes	10

Unpacking the Module

Preparing the Product for Installation

Contact your dealer right away if any items are missing.

Follow the steps below before module installation:

1. Check the equipment if any invisible damage may have occurred during the transit.

2. Confirm that all items on the packing list have been received.
3. Remove all the packing materials as well as electrostatic-resistant packing if available for the equipment.
4. Keep these packing for future use.

Check the Packing List

Table 2-2 Packed Components

Model No	Module
SDM6803N	SDM6803N module: 1pc; Back connector: 1set

Installing the Module

Caution: Static electricity may cause sensitive semiconductor out of order. Avoid installing or removing the module in the electrostatic-induced environment.

Follow the following steps to install the module:

Step 1

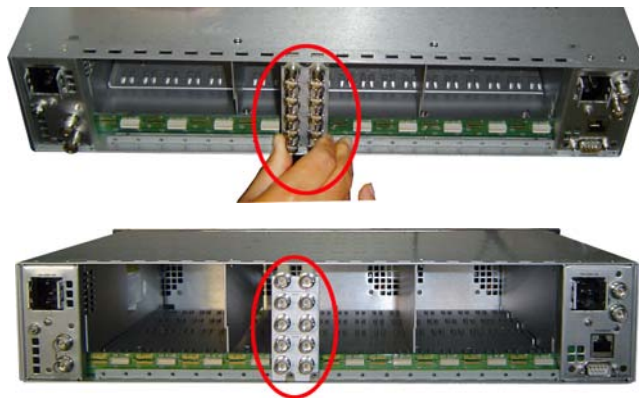

Step2



Step3



Step 4



Step5



Fig. 2-1 Installation of 2U Frame of 6800N Series

1. Locate the position for back connector and insert the back connector
2. Fasten the screw to fix the back connector.
3. Locate the slot for module.
4. Get the module installed in the slot, push the module slightly along the slot, press module again to confirm that the module is installed firmly and then close swivel handle.
5. Install the front panel.

Making the Connections

Make corresponding signal connections based on the module type you purchased. Refer to **Table 1-2** for interface.

Module Removal

When removing the SDM6803N, Observe the following steps:

1. Open the front panel.
2. Open the swivel handle to the full.



3. Hold the swivel handle, pull the module along the slot out of frame.
4. Take out the module and install the front panel.

Chapter 3 Operation and Control

All the functions and working modes of SDM6803N are introduced on the following subjects in this chapter:

- Instructions on User Control and Operation
- Instructions on Parameter Setting
- Instructions on LED Indicator

Instructions on Control and Operation

Refer to **Figure 3-1** or **Table 3-1** (Bank 0) to complete control.

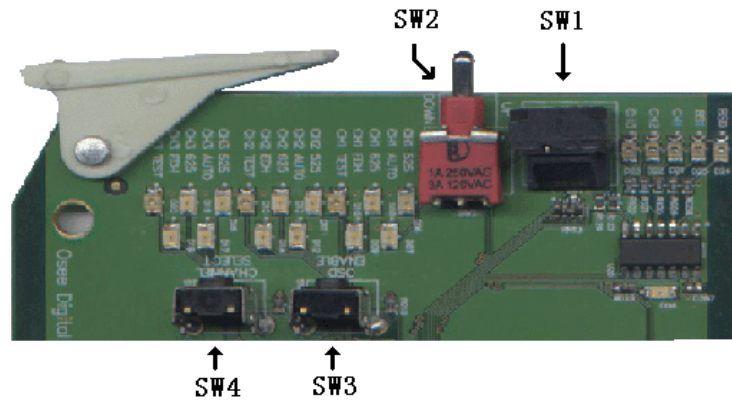

Figure 3-1 The Positions of SW1 SW2 SW3 and SW4

Make SW1 at the position of 0, and select the proper Bank by SW2.

Bank Selection

The SW1 has two Banks

Set the SW1 at the position of “0”. The position of “0” is always used to select Bank.

Set the SW2 at the position of “UP” to select Bank 0, LED of Bank 1 is off. Set the SW2 at the position of “DOWN” to select Bank, LED of Bank 1 is on.

Set the SW1 as default, Refer to Table 3-1 for default

1. SW1 Mode Selection

The SW1 is a 16-position rotary switch, which is used to select the specific setting.

The selection range is: 0, 1, 2, 3, 4, 5, 6, 7, 8, 9, A, B, C, D, E, F.

2. SW2 Mode Selection

The SW2 is a 3-position toggle switch, used to decide the concrete figure of the setting made by SW1.

To keep the SW2 at the position of “UP” or “DOWN”, the continuous adjustment can be achieved.

3. SW3

Press the SW3 to activate OSD.

4. SW4

The SW4 is used to select different channels.

Table 3-1 Bank 0 SW1 Function Setting

SW1 Location	Function	UP: SW2+ DOWN: SW2-	Default
0	Select Bank	0:0 Bank Select Bank 0/1	Bank 0
1	Select Mode	0:1 SDI Vid Std 525/625/Auto	AUTO
2	Select standards Only for 525	0:2 Out 525 Std NTSC	NTSC

		PAL-M	
3	Video setup Only for 525	0:3 Video Setup ON/OFF	ON
4	Chrominance	0:4 Chroma Enable/Disable	Enable
5	Select Test Signal	0:5 Test Signal ON/OFF	OFF
6	Select Audio Group	0:6 Aud Group Group 1/2/3/4	Group 1
7~E	Reserved		
F	Default	0:F Recall Def Restore? Restored	

Table 3-2 Bank 1 SW1 Function Setting

SW1 Location	Function	UP: SW2+ DOWN: SW2-	Default
0	Select Bank	1:0 Bank Select Bank 0/1	Bank 0
1	Black Field Threshold	1:1 Black Thd 0~255	30
2	Freeze Frame Delay	1:2 Freeze Delay 0~255	30
3	Deemed Freeze Frame	1:3 Freeze Thd 0~255	30
4	No Audio Delay	1:4 No Aud Delay 0~255	30
5	No Audio Standards to Select	1:5 No Aud Thd -72/-66 /-60 /-54 /-48 dB	-60dB
6	EDH Detect	1:6 EDH Packet Detect EDH No EDH	Read only
7	EDH Error Number	1:7 EDH Err Num 0~65535	Read only
8	Input Video Standard	1:8 In Video Std 525/625	Read Only
9	Goup1 Status	1:9 Group1 Pres Yes/No	Read only
A	Goup2 Status	1:A Group2 Pres Yes/No	Read only
B	Goup3 Status	1:B Group3 Pres Yes/No	Read only
C	Goup4 Status	1:C Group4 Pres Yes/No	Read only
D~E	Reserve		
F	Product Information	1:F Device SDM6803	

Instructions on Parameters Setting

When the SDM6803N is powered on, its default status is Bank 0.

Through ERROR Detect, identify whether the input signal or reference signal is correct or not.

Keeping the SW2 at the position of “UP” or “DOWN” , a continuous adjustment can be achieved.

When the SW1 rotated to the position of “F” during Bank 0, and take SW2 up or down, the parameters will be restored to the default.

Note: Each channel has independent Bank for setting. Meanwhile pay attention to LED status for CH1,

CH2 and CH3.

LED

Table 3-3 LED Indicator Function

BS0、BS1	Orange	On. Indicates Bank figure and set figure in binary.
CH1 525	Green	On. Working in 525.
CH1 AUTO	Green	On. Working in a format by detecting automatically.
CH1 625	Green	On, Working in 625.
CH1 EDH	Green	If LED is on, it indicates EDH is correct. While LED is flickering, it indicates EDH is wrong. If LED is off, it shows no EDH kit.
CH1 TEST	Orange	On. Preview signal outputs test signal.
CH1、CH2、CH3	Orange	On. Current channel is selected.
CH2 525	Green	On. Working in 525.
CH2 AUTO	Green	On. Working in a format by detecting automatically.
CH2 625	Green	On. Working in 625.
CH2 EDH	Green	If LED is on, it indicates EDH is correct. While LED is flickering, it indicates EDH is wrong. If LED is off, it shows no EDH.
CH2 TEST	Orange	On. Indicating that a color bar test signal is generated
CH3 525	Green	On. Working in 525
CH3 AUTO	Green	On. Working in a format by detecting automatically
CH3 625	Green	On. Working in 625
CH3 EDH	Green	If LED is on, it indicates EDH is correct. While LED is flickering, it indicates EDH is wrong. If LED is off, it shows no EDH kit.
CH3 TEST	Orange	On. Indicating that a color bar test signal is generated

Chapter 4 Specifications

In this chapter, the specifications of SDM6803N on the following subjects are introduced:

- SDI Video Input
- SDI Video Output
- Analog Composite Video Output

SDI Video Input

Table 4-1 SDI Video Input Specifications

Item	Parameter
Standards	SMPTE 259M; 270 Mbps, 525/625 SDI Component
Impedance	75Ω termination
Return Loss	18dB to 360MHz
Connector	BNC (IEC169-8)
Equalization	Auto to 30dB@270 Mbps

SDI Video Output

Table 4-2 SDI Video Output Specifications

Item	Parameter
Standards	SMPTE 259M-C; 270 Mbps, 525/625 SDI component
Connector	BNC (IEC169-8)
Impedance	75Ω
Return Loss	18dB to 270MHz
Signal Level	800 mV ± 10%
DC Offset	0 V ± 0.5 V
Rise/Fall Time	400 to 1500ps (20% to 80% of amplitude)
Overshoot	<10%
Jitter	<0.2 UI (740ps) Peak

Analog Composite Video Output

Table 4-3 Analog Composite Video Output Specifications

Item	Parameter
Standards	NTSC, PAL or PAL-M
Level	1V _{p-p} ±3dB
Impedance	75Ω
Return Loss	>40 dB to 5 MHz
DC Offset	0V±0.05 V
Frequency Response	±0.2 dB to 5 MHz
Differential Gain	<1%
Differential Phase	<1.5°
Group Delay	+/-10ns to 5 MHz

Note: Specifications are subject to change without notice

Chapter 5 Warranty for osee product

What the warranty covers:

osee warrants its products to be free from defects in material and workmanship during the warranty period of two year from purchase date. If a product proves to be defective in material or workmanship during the warranty period, osee will, at its sole option, repair or replace the product with a similar product. The replacement unit will be covered by the balance of the time remaining on the customer's original limited warranty.

No sales personnel of the seller or any other person is authorized to make any warranties other than those described above, or to extend the duration of any warranties on behalf of osee, beyond the time period describe above.

This warranty is extended to the first consumer only, and proof of purchase is necessary to honor the warranty. If there is no proof of purchase provided with a warranty claim, osee reserves the right not to honor the warranty set forth above. Therefore, labor and parts may be charged to the consumer.

What the warranty does not cover:

1. Any product on which the serial number has been defaced, modified or removed.
2. Damage, deterioration or malfunction resulting from:
 - Accident, misuse, neglect, fire, water, lightning, or other acts of nature, unauthorized product modification, or failure to follow instructions supplied with the product
 - Repair or attempted repair by anyone not authorized by osee
 - Any damage of the product due to shipment.
 - Removal or installation of the product.
 - Causes external to the product, such as electric power fluctuations or failure.
 - Use of supplies or parts not meeting osee product's specifications.
 - Normal wear and tear.
 - Any other cause which does not relate to a product defect.