

SMX6810N(S)
Analog Audio Embedding
Module

USER MANUAL



Product Information

Model: SMX6810N(S) Analog Audio Embedding Module
Version: V010000
Release Date: February 8th, 2010

Company

OSEE TECHNOLOGY CO., LTD.

Contact Information

Address: No.22 Building, No.68 zone, Beiqing Road, Haidian District,
Beijing, China
Post Code: 100094
Tel: (+86) 010-62434168
Fax: (+86) 010-62434169
Web: <http://www.osee-dig.com/>
E-mail: sales@osee-dig.com

Contents

Chapter 1 Introduction.....	1
Overview	1
Features.....	1
Module Descriptions	2
The Front Part of Module	2
Back Connector	2
SMX6810N(S)	3
Signal Flow	4
Chapter 2 Installation.....	4
Overview	4
Maximum Power Ratings for Frame.....	5
Unpacking the Module.....	5
Preparing the Product for Installation	5
Check the Packing List	5
Installing the Module	5
Install the front panel. Making the Connections	6
Removing the Module.....	6
Setting Jumper	7
LED Indicator	8
Chapter 3 Operation and Control	9
Switches and Key	9
OSD menu.....	11
Chapter 4 Specifications.....	15
SDI Video Input.....	15
SDI Video Output.....	16
Analog Audio Input.....	16
Analog Video Output	16
DATA IN.....	17
Power Consumption.....	17
Chapter 5 Warranty for osee product.....	18
What the warranty covers.....	18
What the warranty does not cover	18

SMX6810N(S) Analog Audio Embedding Module

Chapter 1 Introduction

Overview

The SMX6810N/ SMX6810NS are analog audio embedding modules. It has embedded SDI output with reclocking. The only difference between two modules is the SMX6810NS features audio tracking in addition to all functions that the SMX6810N offer. Both modules support 4-channel analog audio embedding. The user can choose either input audio or other audio synthesized by system and embed them into any audio group. The module has its own features stated as Tab. 1-1:

Tab. 1-1 SMX6810N(S) Analog Audio Embedding Module

Module	Input	output
SMX6810N	One channel SDI input four channels analog audio inputs	Four channels re-clocked and audio embedded SDI outputs , One channel CVBS output
SMX6810NS	One channel SDI input four channels analog audio inputs One channel DATA IN input	Three channels re-clocked and audio embedded SDI outputs, One channel CVBS output. One channel selectable, re-clocked and audio embedded SDI output

Note: For SMX6810NS, there is one channel which can be set between DATA IN input and SDI output, by the jumper JP16. DATA IN is the audio tracking signal.

Features

The SMX6810N(S) offers the following features:

- ✓ Supporting audio embedding in 525/625 video format
- ✓ Supporting 4-channel audio embedding
- ✓ Supporting 20-bit, 24-bit audio embedding
- ✓ Embedded audio group and mode selectable
- ✓ SDI output with equalization and reclocking
- ✓ One analog video output monitoring
- ✓ SD-SDI video input auto detection and input status feedback
- ✓ Supporting 4-channel audio metering display
- ✓ Embedding tone at fixed frequency rate
- ✓ Supporting 1.3 second at maximum audio delay
- ✓ Supporting audio gain adjustment, invert and mute
- ✓ Input EDH monitoring
- ✓ Re-insert EDH
- ✓ Auto detect freeze frame, black field and video loss
- ✓ Monitoring audio loss and audio overload

FCC Caution:

Any Changes or modifications not expressly approved by the party responsible for compliance could void the user's authority to operate the equipment.

This device complies with part 15 of the FCC Rules.

Operation is subject to the following two conditions: (1) This device may not cause harmful interference, and (2) this device must accept any interference received, including interference that may cause undesired operation.

Note: This equipment has been tested and found to comply with the limits for a Class B digital device, pursuant to part 15 of the FCC Rules. These limits are designed to provide reasonable protection against harmful interference in a residential installation. This equipment generates uses and can radiate radio frequency energy and, if not installed and used in accordance with the instructions, may cause harmful interference to radio communications. However, there is no guarantee that interference will not occur in a particular installation. If this equipment does cause harmful interference to radio or television reception, which can be determined by turning the equipment off and on, the user is encouraged to try to correct the interference by one or more of the following measures:

Reorient or relocate the receiving antenna.

Increase the separation between the equipment and receiver.

Connect the equipment into an outlet on a circuit different from that to which the receiver is connected.

Consult the dealer or an experienced radio/TV technician for help.

Module Descriptions

The Front Part of Module

Figure 1-1 shows the board of SMX6810N(S)



Fig. 1-1 The board of SMX6810N(S)

Back Connector

SMX6810N(S)

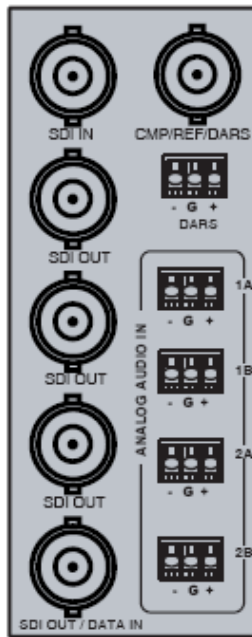

Fig.1-2 Back Connector of SMX6810N(S)

Tab. 1-2 description of SMX6810N(S) Back Connector

Item	Description
SDI IN	SDI input
SDI OUT	Re-clocked SDI output
SDI OUT/DATA IN	<ul style="list-style-type: none"> • For SMX6810N, it is only used for SDI output. • For SMX6810NS, it can be set between DATA IN input and SDI output, by the jumper JP16. DATA IN is the audio tracking signal. The default factory value is DATA IN.
CMP/REF/DARS	Analog Composite Video output
DARS	Reserved.
ANALOG AUDIO IN:1A, 1B, 2A, 2B	Analog audio Input.

Signal Flow

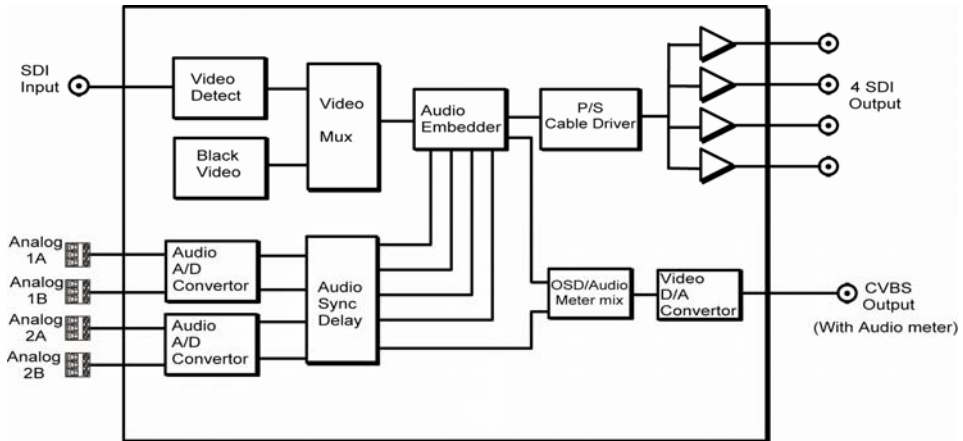

Fig. 1-3 Signal Flow of SMX6810N

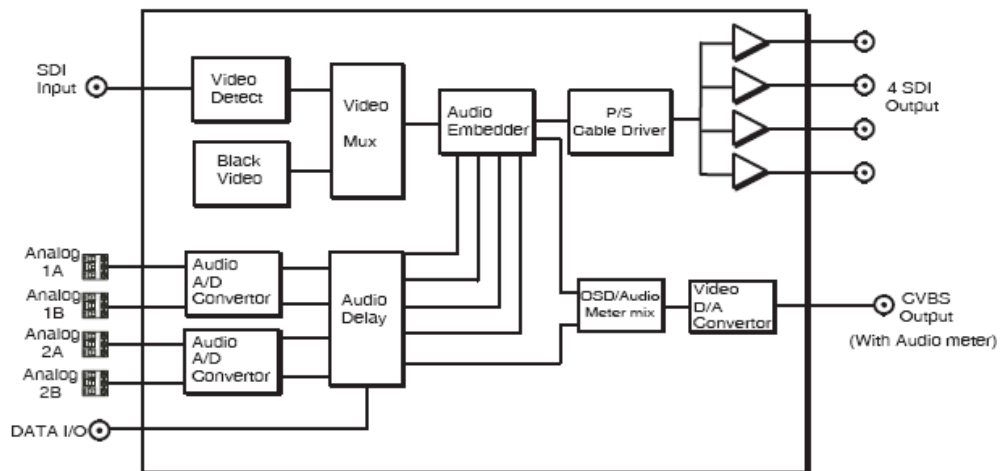

Fig. 1-4 Signal Flow of SMX6810NS

Chapter 2 Installation

Overview

The power consumption for module and the maximum power ratings that frame can sustain have to be confirmed before installing the module.

In this chapter, the following topics on installation process for SMX6810N(S) are discussed below:

- Unpacking the module
- Setting Jumper
- Installing the module
- Making the connections
- Removing the module

Maximum Power Ratings for Frame

The maximum power ratings that different types of frames can sustain are listed in the Table 2-1

Tab. 2-1 Maximum Power Consumption

Frame	Maximum Voltage	Redundant Power Supplies	Numbers of Slots
6800N-1U	40W	Yes	4
6800N-2U	60W	Yes	10

Unpacking the Module

Preparing the Product for Installation

Contact your dealer right now if any items are missing.

Follow the procedures below before installing the module:

- Check the equipment for any invisible damage that may have occurred during transit.
- Confirm all the items listed on the packing list have been received.
- Remove all the packing material including electrostatic-resistant packing.
- Retain these packing for future use.

Check the Packing List

Tab. 2-2 Packed Components

Model Name	Description
SMX6810N(S)	SMX6810N(S) module (1pc); back connector (1pc), and other accessories

Installing the Module

Caution: Static electricity may cause sensitive semiconductor out of order. Avoid installing or removing the module in the electrostatic-induced environment.

Follow the following steps to install the module:

Step 1

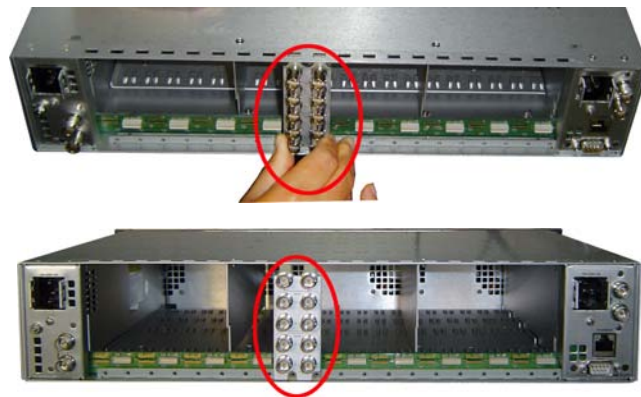

Step2

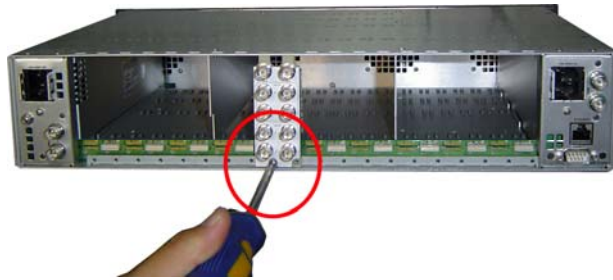

Step3



Step 4



Step5



Fig. 2-1 Installation of 2U Frame of 6800 Series

- ✓ Locate the position for back connector and insert the back connector
- ✓ Fasten the screw to fix the back connector.
- ✓ Locate the slot for module.
- ✓ Get the module installed in the slot, push the module slightly along the slot, press module again to confirm that the module is installed firmly and then close swivel handle.
- ✓ Install the front panel.

Install the front panel. Making the Connections

Please connect signals based on Fig. 1-2.

Removing the Module

Follow the following steps to remove SMX6810N(S) module:

1. Open the front part of frame.

2. Open the swivel handle to the full.



3. First make sure the frame stands firmly, and then pull the module gently along the slot till out of frame.
4. Install the front panel.

Setting Jumper

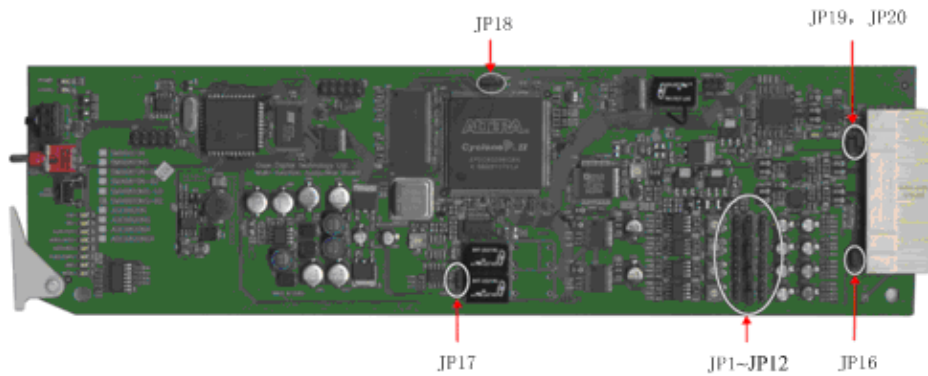

Tab. 2-3 Description of SMX6810N(S) Jumpers

Item	Description
JP1~JP12	Setting the gains of 4-channel audio input. Adjust the jumper to set the value of the board silk. +16/+18/+20/+22/+24/+26/+28dB adjustable. The default setting is +24dB. <ul style="list-style-type: none"> • From jp1, jp2 and jp3, it can adjust the gains of audio 1A input. Adjust the jumper to set the corresponding value of the board. • From jp4, jp5 and jp6, it can adjust the gains of audio 1B input. • From jp7, jp8 and jp9, it can adjust the gains of audio 2A input. • From jp10, jp11 and jp12, it can adjust the gains of audio 2B input.
JP16	DATA/SDI. The default setting is "DATA". <ul style="list-style-type: none"> • For SMX6810N, it is only used for SDI output. • For SMX6810NS, it is a selectable jumper and can be set between DATA IN input and SDI output, by the jumper JP16. DATA IN is the audio tracking signal. <ol style="list-style-type: none"> 1. When it is set to "SDI", the back connector port of "SDI OUT/DATA IN" outputs the SDI with relocking and embedded audio. 2. When it is set to "DATA", the back connector port of "SDI OUT/DATA IN" is used for DATA IN.
JP17	DATA IN TERMINATION ON/OFF. It is used for the termination of the DATA IN signal and only used for SMX6810NS Module. When many modules share one DATA signal, just jumper to ON to enable the 75 Ω input termination. The default setting is ON. <ul style="list-style-type: none"> • ON: 75 Ω input termination is available.

Item	Description
	<ul style="list-style-type: none"> • OFF: 75 Ω input termination is unavailable.
jp18 (used to choose control mode)	<p>(LOC/RMT)/LOCAL. It is adjustable. The default setting is LOC/RMT.</p> <ul style="list-style-type: none"> • When the “LOC/RMT” is selected, the module is controlled not only by a variety of switches on the local module card, but also by the remote control network. • When the “LOCAL” is selected, the module is controlled only by the switches on the local module card.
JP19, JP20	<p>The jumpers are un-adjustable.</p> <p>The default setting: JP19: COMP; JP20: DARS.</p>

LED Indicator

Table 2-4 LED Indicator Function

Item	Description
POWER (green)	On: Power is supplied.
CONFIG (orange)	On: The device is Initializing.
BS0/BS1 (orange)	<p>On: select BANK. The combination of the two LED lights indicates the present state of Bank. It indicates the Bank number in binary mode.</p> <p>For the details, please see the Tab.2-5.</p>
AUD1/525 (green)	<p>1. When working on Mode A:</p> <ul style="list-style-type: none"> • On: In SDI output, there is right information about embedded audio channel 1A. • Flickering: In SDI output, there is wrong information about embedded audio channel 1A. • Off: In SDI output, there is no information about embedded audio channel 1A. <p>2. When working on Mode B:</p> <ul style="list-style-type: none"> • On: the input video format is 525 and conforms to the video format what you have set. • Flickering: the input doesn't conform to the video format 525 what you have set. • Off: no signal input.
AUD2/AUTO (green)	<p>1. When working on Mode A:</p> <ul style="list-style-type: none"> • On: In SDI output, there is right information about embedded audio channel 1B. • Flickering: In SDI output, there is wrong information about embedded audio channel 1B. • Off: In SDI output, there is no information about embedded audio channel 1B. <p>2. When working on Mode B:</p> <ul style="list-style-type: none"> • On: Video standard is set to AUTO, and it can be auto detected.
AUD3/625 (green)	<p>1. When working on Mode A:</p> <ul style="list-style-type: none"> • On: In SDI output, there is right information about embedded audio channel 2A. • Flickering: In SDI output, there is wrong information about embedded audio channel 2A. • Off: In SDI output, there is no information about embedded audio channel 2A. <p>2. When working on Mode B:</p>

Item	Description
	<ul style="list-style-type: none"> • On: the input video format is 625 and conforms to the video format what you have set. • Flickering: the input doesn't conform to the video format 625 what you have set. • Off: no signal input.
AUD4/DARS	<ul style="list-style-type: none"> • On: In SDI output, there is right information about embedded audio channel 2B. • Flickering: In SDI output, there is wrong information about embedded audio channel 2B. • Off: In SDI output, there is no information about embedded audio channel 2B.
EBD	<ul style="list-style-type: none"> • On: the embedded audio is right. • Flickering: there is wrong information about embedded audio. • Off: no embedded audio information.
MODE	On: Mode B, Off: Mode A

Note: When the user selects the different LED mode, the LED Indicator displays differently. The LED mode can be set in the "E" item of Bank 0.

Tab. 2-5 Description of DBS Indicator

BS0	BS1	Bank Number
off	off	Bank 0
on	off	Bank 1
off	on	Bank 2
on	on	Bank 3

Chapter 3 Operation and Control

Switches and Key

Refer to **Figure 3-1** or **Table 3-1** (BANK 0) or **Table 3-2** (BANK 1) or **Table 3-3** (BANK 2) or **Table 3-4** (BANK 3) to complete control

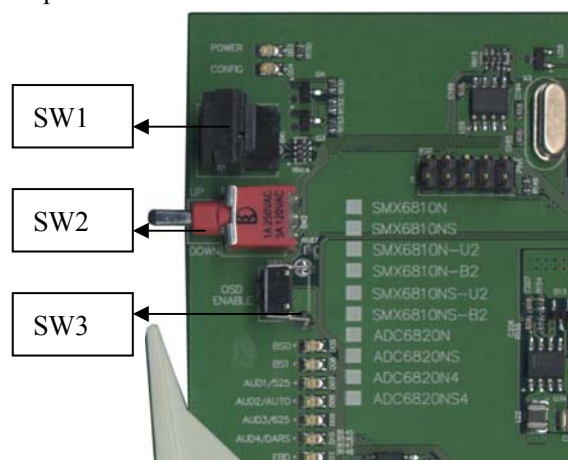

Fig. 3-1 Switches and key

Rotate SW1 at the position of 0, and select the proper BANK by SW2.

BANK Selection

The SW1 has four Banks

Rotate the SW1 at the position of “0”. The position of “0” is always used to select BANK.

Turn SW2 up or down to select BANK.

1. SW1 Mode Selection

SW1 is a 16-position rotary switch, which is used to select the specific setting.

The selection range is: 0, 1, 2, 3, 4, 5, 6, 7, 8, 9, A, B, C, D, E, F.

2. SW2 Mode Selection

SW2 is a toggle switch, which is used to decide the concrete figure of the setting made by SW1.

SW2 is a 3-position toggle switch, used to decide the concrete figure of the setting made by SW1.

To keep SW2 at the position of “UP” or “DOWN”, the continuous adjustment can be achieved.

3. SW3

Press the SW3 to activate OSD.

When the user does not operate the board, the OSD menu will disappear after 10 seconds.

For analog Composite output, it adds the audio meter and the OSD menu. To monitor the audio and the menu item, please connect the analog Composite output signal to one monitor which supports the analog Composite video input.

The audio meter and the OSD menu are shown as bellow.



OSD menu
Tab. 3-1 BANK 0 Function Setting

SW1	Function	Options	Default
0	Bank Select	Bank 0~Bank 3	Bank 0
1	Vid Std Sel: Select the input video signal standard.	525/625/AUTO	AUTO
2	Out Vid Std: Select the output video signal standard. Only for the input video signal of 525 standard. For 625 standard, this item is unavailable.	NTSC/PAL-M	NTSC
3	Reserve		
4	Audio Track: Enable the audio tracking or not. (only used for SMX6810NS module)	ON/OFF	ON
5	ANC Clean: Clean the auxiliary datum of SDI input signal or not.	ON/OFF	OFF
6	Embed Bits: Set the bits of embedded audio	20bits/24bits	24
7	Embed Mod: Set the mode of embedded audio	overwrite/Append /Auto	Auto
8	Embed Enable: Enable the embedded audio or not.	Enable/Disable	Enable
9	Embed Group: Select the embedded audio Group	Group 1/Group 2/ Group 3/Group 4	Group 1
A	Out Ch1A Sel: Select audio source of the embedded audio output channel 1A	In 1A/ In 1B/ In 2A/ In 2B/In 1 Sum/ In 2 Sum/Tone 1/ Tone 2/Mute	In 1A
B	Out Ch1B Sel: Select audio source of the	In 1A/ In 1B/ In 2A/ In 2B/In 1 Sum/	In 1B

SW1	Function	Options	Default
	embedded audio output channel 1B	In 2 Sum/Tone 1/ Tone 2/Mute	
C	Out Ch2A Sel: Select audio source of the embedded audio output channel 2A	In 1A/ In 1B/ In 2A/ In 2B/In 1 Sum/ In 2 Sum/Tone 1/ Tone 2/Mute	In 2A
D	Out Ch2B Sel: Select audio source of the embedded audio output channel 2B	In 1A/ In 1B/ In 2A/ In 2B/In 1 Sum/ In 2 Sum/Tone 1/ Tone 2/Mute	In 2B
E	Led Mode: Select the LED light mode	Mode A/Mode B	Mode A
F	Recall def: Recall the default setting.	Restore ?/Restored	

Note: For Bank 0 “7”, audio embedded mode:

- For the overwrite mode, in the video source, it must exist the audio group where can be embedded. For example, in order to embed audio Group 1, there must be the audio Group1 existing in the SDI input signal.*
- For the Append mode, in order to embed audio Group, there must **not** be the audio Group1 existing in the video source.*
- For the Auto mode, regardless of the existence of embedded audio Group in the video sources, all can be embedded the audio.*

Tab. 3-2 BANK 1 Function Setting

SW1	Function	Options	Default
0	Bank Select	Bank 0~Bank 3	Bank 0
1	In Ch1A Lev: Adjust the levels of input audio channel 1A.	-96 to +12dB in 0.5dB step	+0.0dB
2	In Ch1B Lev: Adjust the levels of input audio channel 1B.	-96 to +12dB in 0.5dB step	+0.0dB
3	In Ch2A Lev: Adjust the levels of input audio channel 2A.	-96 to +12dB in 0.5dB step	+0.0dB
4	In Ch2B Lev: Adjust the levels of input audio channel 2B.	-96 to +12dB in 0.5dB step	+0.0dB
5	Ch1A Delay:	0 to 1320ms in 1ms	0ms

SW1	Function	Options	Default
	Adjust the delay of input audio channel 1A.	step	
6	Ch1B Delay: Adjust the delay of input audio channel 1B.	0 to 1320ms in 1ms step	0ms
7	Ch2A Delay: Adjust the delay of input audio channel 2A.	0 to 1320ms in 1ms step	0ms
8	Ch2B Delay: Adjust the delay of input audio channel 2B.	0 to 1320ms in 1ms step	0ms
9	In Ch1A Inv: Adjust the embedded input audio channel 1A to invert.	On/Off	Off
A	In Ch1B Inv: Adjust the embedded input audio channel 1B to invert.	On/Off	Off
B	In Ch2A Inv: Adjust the embedded input audio channel 2A to invert.	On/Off	Off
C	In Ch2B Inv: Adjust the embedded input audio channel 2B to invert.	On/Off	Off
D~F	Reserve		

Tab. 3-3 BANK 2 Function Setting

SW1	Function	Options	Default
0	Bank Select	Bank 0~Bank 3	Bank 0
1	Meter1 Type: Select the display type of audio meter1(CH1A , CH1B)	Off/VU/ PPM/VU+PPM	VU+PPM
2	Meter2 Type: Select the display type of audio meter2(CH2A , CH2B)	Off/VU/ PPM/VU+PPM	VU+PPM
3	Meter1 H Pos: Select the horizontal position of audio Meter1	1 to 168	7

SW1	Function	Options	Default
	(CH1A, CH1B)		
4	Meter2 H Pos: Select the horizontal position of audio Meter2 (CH2A, CH2B)	6 to 174	168
5	Test Level: Select the test level of audio meter.	-18dB/-20dB	-18dB
6	Black Thd: The threshold of Black burst triggering.	1 to 255 in 1 step	30
7	Freeze Delay: The delay of Freeze detected	1 to 255 in 1 step	30
8	Freeze Thd: The threshold of Freeze triggering.	1 to 255 in 1 step	30
9	No Aud Delay: The delay of no audio detected	1 to 255 in 1 step	30
A	No Audio Thd: The threshold of no audio detected.	-72 dB, -66 dB, -60 dB, -54 dB, -48dB	-60dB
B~F	Reserve		

Tab. 3-4 BANK 3 Status Displaying Table

SW1	Function	Options	Default
0	Bank Select	Bank 0~Bank 3	Bank 0
1	Video Std: Display the input video standard.	525/ Auto 525 625/ Auto 625	Read only
2	In vid status: Display the input video status	Loss , Black , Freeze , Normal	Read only
3	Group Pres: Display the audio group embedded in the input	-----/G1----- /--G2---/G1G2---- /---G3--/G1--G3--	Read only

SW1	Function	Options	Default
	video.	/--G2G3--/G1G2G3-- /-----G4/G1----G4 /--G2--G4/G1G2--G4 /---G3G4/G1--G3G4 /--G2G3G4/G1G2G3G4	
4	In Aud sta: Display the status of the four embedded audio channels	O: overload/ V: normal , /X:no audio	Read only
5	EDH Packet: Display the status of the EDH Packet	no EDH/Detect EDH /EDH Err	Read only
6	EDH Err Num: The sum of EDH error numbers. (Clear the counter by the toggle switch up or down)	0 to 32767	
7~C	Reserve		
D	Modular mod: Display the modular mode.	SMX6810N or SMX6810NS	Read only
E	Version info: Version information.	Display the version of hardware and software.	Read only
F	Hardware sta: Hardware status	Correct/Error	Read only

Note: the Bank 3 is used to display the status.

“3” Group Pres: Display the audio group embedded in the input video. For example, the “G1--G3--” indicates that there are audio Group 1 and Group 3 embedded in input video.

Chapter 4 Specifications

SDI Video Input

Table 4-1 SDI Video Input Specifications

Item	Parameter
Standards	SMPTE 259M-C, 270 Mbps, 525/625 SDI Component
Impedance	75Ω termination
Return Loss	>18dB to 360MHz

Item	Parameter
Connector	BNC (IEC169-8)
Equalization	Auto to 30dB@270 Mbps

SDI Video Output

Table 4-2 SDI Video Output Specifications

Item	Parameter
Standards	SMPTE 259M-C, 270 Mbps, 525/625 SDI component
Connector	BNC (IEC169-8)
Impedance	75Ω
Return Loss	>18dB to 270MHz
Signal Level	800 mV ± 10%
DC Offset	0 V ± 0.5 V
Rise/Fall Time	400 to 1500ps (20% to 80% of amplitude)
Overshoot	<10%
Jitter	<0.2 UI (740ps) Peak

Analog Audio Input

Tab. 4-6 Analog Audio Input Specifications

Item	Parameter
Connector	3-pin
Analog Input Level	28-16dBu
Impedance	>30Kohm
Frequency Response	+/-0.05dB (20-20KHz)
THD+N	95dB, 20-20KHz@-3dBFS
Crosstalk	-95dB(20-20KHz)

Analog Video Output

Tab. 4-3 Analog Video Output Specifications

Item	Parameter
Standard	NTSC, PAL or PAL-M
Level	1Vp-p +/-3dB
Impedance	75 Ω
Connector	BNC(IEC169-8)
Return loss	>40 dB to 5 MHz

DC offset	0V±0.05 V
Frequency response	±0.2 dB to 5 MHz
Differential gain	<1%
Differential phase	<1.5°
Propagation delay	+/-10ns to 5 MHZ

DATA IN

Item	Parameter
Input Impedance	75 Ω /high impedance (jumper selectable)
Input Sensitivity	500mV pk to pk (minimum value)
Input Cable Length	100 meter
Return Loss	<-20dB

Power Consumption

Power	3.25W
Positive Rail	500 mA
Negative Rail	10 mA

Note: Specifications are subject to change without notice

Chapter 5 Warranty for osee product

What the warranty covers:

osee warrants its products to be free from defects in material and workmanship during the warranty period of two year from purchase date. If a product proves to be defective in material or workmanship during the warranty period, osee will, at its sole option, repair or replace the product with a similar product. The replacement unit will be covered by the balance of the time remaining on the customer's original limited warranty.

No sales personnel of the seller or any other person is authorized to make any warranties other than those described above, or to extend the duration of any warranties on behalf of osee, beyond the time period describe above.

This warranty is extended to the first consumer only, and proof of purchase is necessary to honor the warranty. If there is no proof of purchase provided with a warranty claim, osee reserves the right not to honor the warranty set forth above. Therefore, labor and parts may be charged to the consumer.

What the warranty does not cover:

1. Any product, on which the serial number has been defaced, modified or removed.
2. Damage, deterioration or malfunction resulting from:
 - Accident, misuse, neglect, fire, water, lightning, or other acts of nature, unauthorized product modification, or failure to follow instructions supplied with the product
 - Repair or attempted repair by anyone not authorized by osee
 - Any damage of the product due to shipment.
 - Removal or installation of the product.
 - Causes external to the product, such as electric power fluctuations or failure.
 - Use of supplies or parts not meeting osee product's specifications.
 - Normal wear and tear.
 - Any other cause which does not relate to a product defect.